



Ultimate Pump Controller

Instruction Manual



Water industry telemetry standards
WITS - DNP3 Protocol



ULTIMATE CONTROLLER (THIRD EDITION REV 2)

February 2022

Part Number M-1U0-8-003-2P

COPYRIGHT

© Pulsar Measurement, 2001 -22. All rights reserved. No part of this publication may be reproduced, transmitted, transcribed, stored in a retrieval system, or translated into any language in any form without the written permission of Pulsar Measurement.

WARRANTY AND LIABILITY

Pulsar Measurement guarantee for a period of 2 years from the date of delivery that it will either exchange or repair any part of this product returned to Pulsar Measurement if it is found to be defective in material or workmanship, subject to the defect not being due to unfair wear and tear, misuse, modification or alteration, accident, misapplication, or negligence.

DISCLAIMER

Pulsar Measurement neither gives nor implies any process guarantee for this product and shall have no liability in respect of any loss, injury or damage whatsoever arising out of the application or use of any product or circuit described herein.

Every effort has been made to ensure accuracy of this documentation, but Pulsar Measurement cannot be held liable for any errors.

Pulsar Measurement operates a policy of constant development and improvement and reserves the right to amend technical details, as necessary.

CONTACT

For technical support, please contact:

Europe: supporteurope@pulsarmeasurement.com

Outside Europe: supportnorthamerica@pulsarmeasurement.com

If you have any comments or suggestions about this product, please contact:

Europe: europa@pulsarmeasurement.com

Outside Europe: northamerica@pulsarmeasurement.com

Pulsar Measurement website:

www.pulsarmeasurement.com

United States

11451 Belcher Road South
Largo, FL 3373
888-473-9546

Canada

16456 Sixsmith Drive
Long Sault, Ont, K0C 1P0
855-300-9151

UK

Cardinal Building,
Enigma Business Centre
Sandy's Road, Malvern WR14 1JJ
00 44 (0)1684 891371

CONTENTS

Contents 4

Chapter 1: Start Here... 7

 1.1 About this Manual 7

 1.2 About the Ultimate Controller 7

 1.3 Product Specification 8

 1.4 Declaration of Conformity 10

Chapter 2 Installation 11

 2.1 Power Supply Requirements 11

 2.2 Location 11

 2.3 Safety Symbols 11

 2.4 Dimensions 13

 2.5 Terminal Connection Details 16

 2.6 Fuse Location 19

 2.7 Preparation for Operation 20

 2.8 Maintenance 20

 2.9 RS485 Connectivity 21

Chapter 3 How to Use Your Ultimate Pump Controller 23

 3.1 Run Mode 23

 3.2 Program Mode 37

 3.3 Parameter Defaults 41

Chapter 4 Set Up Menu 42

 4.1 Main Menu 42

 4.2 Application Setup 42

 mA Inputs 45

 Operation 46

 Example Setup: 47

 4.3 Relays 49

 4.4 Pump Advanced 72

 Run Time 75

 Auto Reset 76

 Pumped Volume 77

 Efficiency 80

 Storm Detect 81

 Override 82

 Odour Reduction 82

 Wall Cling 83

 Septicity Prevention 83

 Block & Burst 84

 Peak Tariff 85

 Pump Reversing 87

 Over Spill 90

 Backup 92

 VSD Controls 93

 4.5 Digital Inputs 95

 Common Settings 95

 General 97

 Function 97

Pump.....	98
Backup.....	99
Maintenance.....	100
4.6 Sensors.....	101
Flow Pulse.....	101
Speedy.....	105
MicroFlow.....	108
4.7 Volume.....	111
Setup.....	111
Vessel Shape.....	112
Breakpoints.....	116
4.8 OCM App. (Open Channel Measurement Application).....	118
OCM Setup.....	118
Setup.....	119
Exponent.....	119
BS3680 Flume.....	122
BS3680 Weir.....	124
Area Velocity.....	126
Special.....	128
Universal.....	130
Area Velocity Universal.....	132
Totaliser.....	135
OCM Totaliser Logs.....	137
Breakpoints.....	137
Totalisers.....	138
4.9 Display.....	141
Main Display.....	141
AUX Display.....	142
Failsafe.....	143
Secondary Auxiliary.....	144
4.10 mA Outputs.....	145
4.11 Compensate.....	148
4.12 Stability.....	150
Rate.....	150
Damping.....	151
4.13 Echo Process.....	152
4.14 Remote Alarms.....	153
Remote Alarms.....	153
4.15 Logical Output.....	154
4.16 Simulation.....	157
Chapter 5 Advanced Configuration.....	159
5.1 Modules.....	159
5.2 Live List.....	161
5.3 Log Setup.....	162
5.4 Communications.....	165
5.5 Networking.....	173
5.6 CCTV camera.....	174

5.7 User accounts 176

5.8 General settings..... 178

5.9 Maintenance 181

Chapter 6 System..... 182

6.1 Hardware Test 182

6.2 Soft Default 183

6.3 Setup Profiles..... 184

6.4 Hardware..... 187

6.5 Firmware Upgrade..... 189

6.6 Hard Default..... 189

6.7 Backup Profile..... 190

6.8 Software..... 190

Chapter 7 Asset Management..... 191

7.1 Overall Station Data 191

7.2 Logged Performance Data 192

7.3 Pump Predictive Maintenance 196

7.4 Pumps Info 197

7.5 Alarms Info 198

7.6 Controls Info 198

7.7 Misc. Info 198

Chapter 8 Ultimate Webserver 199

8.1 Webserver key..... 200

8.2 Traces Webpage..... 201

8.3 Parameters Webpage..... 202

8.4 Camera Webpage 213

8.5 Events Webpage..... 213

8.6 Trending Webpage 214

8.7 System Info Webpage..... 215

8.7 Assets Webpage..... 216

Chapter 9 Troubleshooting..... 222

To read a parameter 222

Transducer voltage check 222

Appendix A – Dynamic Parameter Memory Map 223

Appendix B – Ultimate Static Parameter 237

Appendix C – Ultimate Profibus Module Definitions 251

Appendix D - Disposal..... 262

Instructions on returning products to Pulsar 262

Instructions for disposal 262

Notes 263

CHAPTER 1: START HERE...

Congratulations on your purchase of a Pulsar Ultimate Pump Controller. This quality system has been developed over many years and represents the latest in high technology ultrasonic level measurement and control.

It has been designed to give you years of trouble-free performance, and a few minutes spent reading this operating manual will ensure that your installation is as simple as possible.

Disclaimer: Pulsar accepts no responsibility for any loss or damage caused by miss-application of the information contained in this document.

1.1 About this Manual

It is important that this manual is referred to for correct installation and operation.

There are various parts of the manual that offer additional help or information as shown:

Tips



TIP: Look for this icon throughout your Pulsar Measurement manual to find helpful information and answers to frequently asked questions.

Additional Information

Additional Information

At various parts of the manual, you will find sections like this that explain specific things in more detail.

References

— See Also

References to other parts of the manual.

1.2 About the Ultimate Controller

Ultimate Controller integrates intelligent pump control, Remote Telemetry (RTU), and level and flow measurement within one economically sized unit.

Ultimate is the next generation of controller, providing you features never seen before, such as predictive maintenance, pump economy, duty selection and pump station overall efficiency index, as well as sophisticated, advanced routines to cater to your every need. Building on Pulsar's renowned user-friendly operation, **Ultimate** Controller now provides an even easier menu-driven set-up operated through a colour touch-screen HMI.

Ultimate Controller has been designed to be modular and expandable offering you a customised solution. A range of options are available such as an infra-red camera allowing remote monitoring of process and assets, pump power monitoring including pump reversing and other peripherals that provide I/O.

Complete control, monitoring and management – **Ultimate** Controller.

1.3 Product Specification

PHYSICAL

Wall Mount	
Outside Dimensions	225 x 262 x 105 mm (8.85 x 10.3 x 4.13")
Weight	Nominal 2kg (4.4 lb)
Enclosure Material/Description	Polycarbonate flame resistant to UL94-V0
Cable entry detail	11 off: 9 x M20 and 2 x M16 underside
Fascia Mount	
Outside dimensions	124 x 224 x 114mm (4.88 x 8.8 x 4.48")
Weight	1.5kg (3.3 lb)
Enclosure material/description	Stainless steel with Polycarbonate UL94 –V0 front and bezel
Transducer Cable Extensions	2-core screened
Maximum Separation	1000m (3,280 ft), 500m (1,640 ft) for mmWave

ENVIRONMENTAL

IP Rating	Fascia: IP64 (front panel) Wall: IP65 degree 2	Pollution IK06 @ -20°C
Altitude	2000m maximum	
Max. & min. temperature (electronics)	-30 °C to +50 °C (-22°F to 122°F) ambient	
Flammable atmosphere approval	Safe area: compatible with approved dB transducers (see transducer spec' sheet)	
UL Approval	Report Number: E257330-D1000-1/A0/C0	
CE Approval	See EU Declaration of Conformity	

PERFORMANCE

Accuracy	0.25% of the measured range or 6 mm (whichever is greater). mmWAVE ± 2mm.
Resolution	0.1% of the measured range or 2 mm (whichever is greater)
Max. Range	Dependant on transducer (maximum 40m dB40)
Min. Range	Dependent upon application and transducer (minimum zero dB Mach3)
Rate Response	Fully adjustable

OUTPUTS

DATEM	DATEM (D igital A daptive T racking of E cho M ovement)
Analogue Output	2 off Isolated (floating) outputs (to 150V) of 4-20 mA or 0-20 mA into 1KΩ (user programmable and adjustable) 0.1% resolution
Digital Output	
Volt free contacts, number, and rating	8 form "C" (SPDT) rated at 5A max., total of eight 24A maximum.
Display	5.7-inch colour TFT display with capacitive Touch Screen.

INPUTS

Analogue Input	2 off 4-20mA or 0-20 mA sink or source (user programmable and adjustable) 0.1% resolution, open circuit voltage (source mode) 24V, output voltage (source mode) @ 4mA, 22V, @ 20mA, 18V.
Digital Inputs	8 Digital Inputs Min. Input Voltage 5VDC Max. Input Voltage 30VDC (Max. Current 3mA) 24VDC Input Supply maximum total current 24mA.

PROGRAMMING

On-board programming	By Capacitive Touch Screen
Programming security	Via passcode (user selectable and adjustable)
Programmed data integrity	Via non-volatile memory

MEMORY

On-board (internal)	4GB non-volatile memory
External	SD card 4GB supplied

CONNECTIVITY

Mini USB (External)	Connecting of laptop/PC, located under flap on side of unit.
USB 'A' Socket (Internal)	Connecting of peripherals such as modems.
'D' Type 9 pin (Internal)	Connection of optional comms. (Modbus and Profibus), RS232
Camera Port (Internal)	Power and comms. for Pulsar Camera.
Modbus Master 5-way connector (internal)	Connection of Pulsar peripheral devices
Ethernet	External Modem/Network Connection

SUPPLY

Power supply – Mains AC	85 – 264V AC 47 - 400Hz, 50W maximum input power
Fuses (mains)	2A 'T' 20mm fuse
'Power supply (DC)	22 – 28VDC (internally fused 2A 'T')

COMMUNICATIONS

PBUS (Modbus Master)	RS485 Pulsar expansion bus
Modbus (optional)	Modbus RTU, ASCII, TCP/IP
Profibus (optional)	Profibus V1
DNP3 (optional)	DNP3 communications via Ethernet or modem.
RS232 (optional)	Communication via RS232

Pulsar Measurement operates a policy of constant development and improvement and reserve the right to amend technical details, as necessary.

1.4 Declaration of Conformity



EU DECLARATION OF CONFORMITY

PULSAR *Ultimate*

This declaration of conformity is issued under the sole responsibility of the manufacturer

Relevant directive(s)	2014/30/EU - EMC directive and its amending directives. 2014/35/EU - Low Voltage directive and its amending directives. 2011/65/EU - RoHS directive and its amending directives.
Manufacturer's name	Pulsar Process Measurement Ltd.
Manufacturer's address	Cardinal Building, Enigma Commercial Centre, Sandy's Road, Malvern, Worcestershire, WR14 1JJ, UK.
Apparatus	System controller with communications.
Models	Pulsar Ultimate Wall & Fascia mount controllers.
Type of equipment	Measurement and process control.
Standards applied	EN 61010-1:2010+A1:2019 Safety requirements for electrical equipment for measurement, control and laboratory use. EN 61326-1:2013 EMC, equipment class industrial.

I declare that the apparatus named above has been tested and complies with the relevant sections of the above referenced standards & directives.

Signed for and on
behalf of:



Date: 6th April 2021.

Rev. 3.2 .

Name & function: Tim Brown, electronics engineer.

Pulsar Process Measurement Ltd.

CHAPTER 2 INSTALLATION

2.1 Power Supply Requirements

The **Ultimate** can operate from AC / DC supply or from a DC battery. The **AC** range is **100–240V AC 50/60Hz**. The **DC** range is **22-28V**.

2.2 Location

Additional Information

All electronic products are susceptible to electronic shock, so follow proper grounding procedures during installation.

The Ultimate Pump Controller must be mounted in a non-hazardous (safe) area, and the transducer can be fitted in a hazardous area.

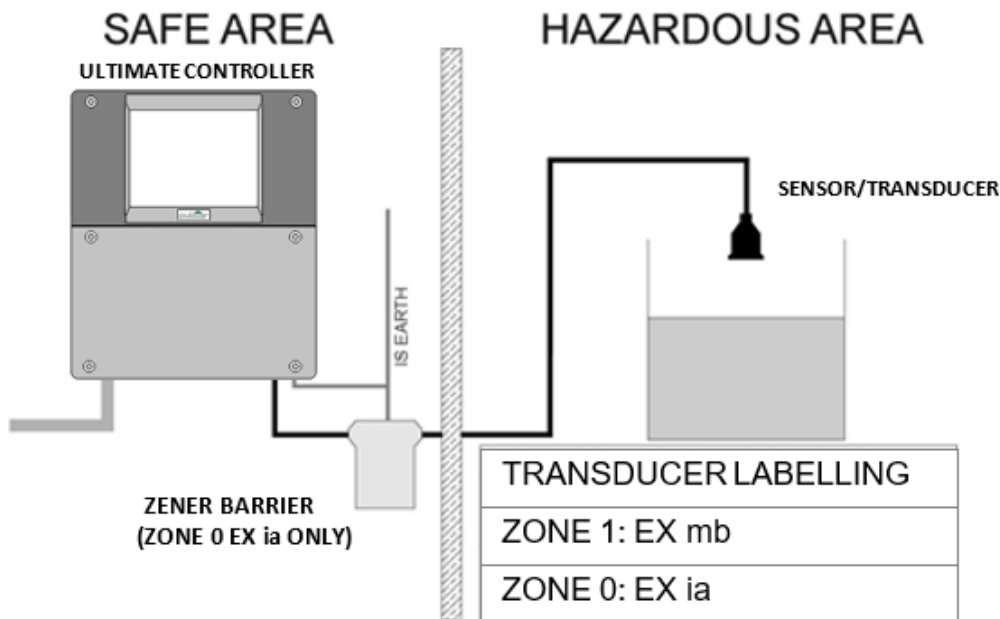

TIP: Refer to sensor/transducer instructions for full details

2.3 Safety Symbols

Detailed below are descriptions and meanings of safety/warning symbols that are used on the Ultimate and in this manual.

SYMBOL	DESCRIPTION
	DIRECT CURRENT (DC)
	ALTERNATING CURRENT (AC)
	PROTECTIVE CONDUCTOR TERMINAL
	FUNCTIONAL EARTH
	CAUTION/MISE EN GARDE (Refer to accompanying Documents)

When choosing a location to mount the enclosure, bear in mind the following:

- Ensure that the Ultimate is installed in a “Safe”, non-hazardous, area.
- Do not mount with the TFT display exposed to direct sunlight.
- For a clear view of the TFT display it is recommended that you mount it at eye level.
- The mounting surface is vibration-free.
- The ambient temperature is between -30°C and +50°C (-22°F and +122°F).
- There should be no high voltage cables or inverters close by.
- Avoid mounting adjacent to or above heat sources. Refer to the diagram below for recommended clearances.

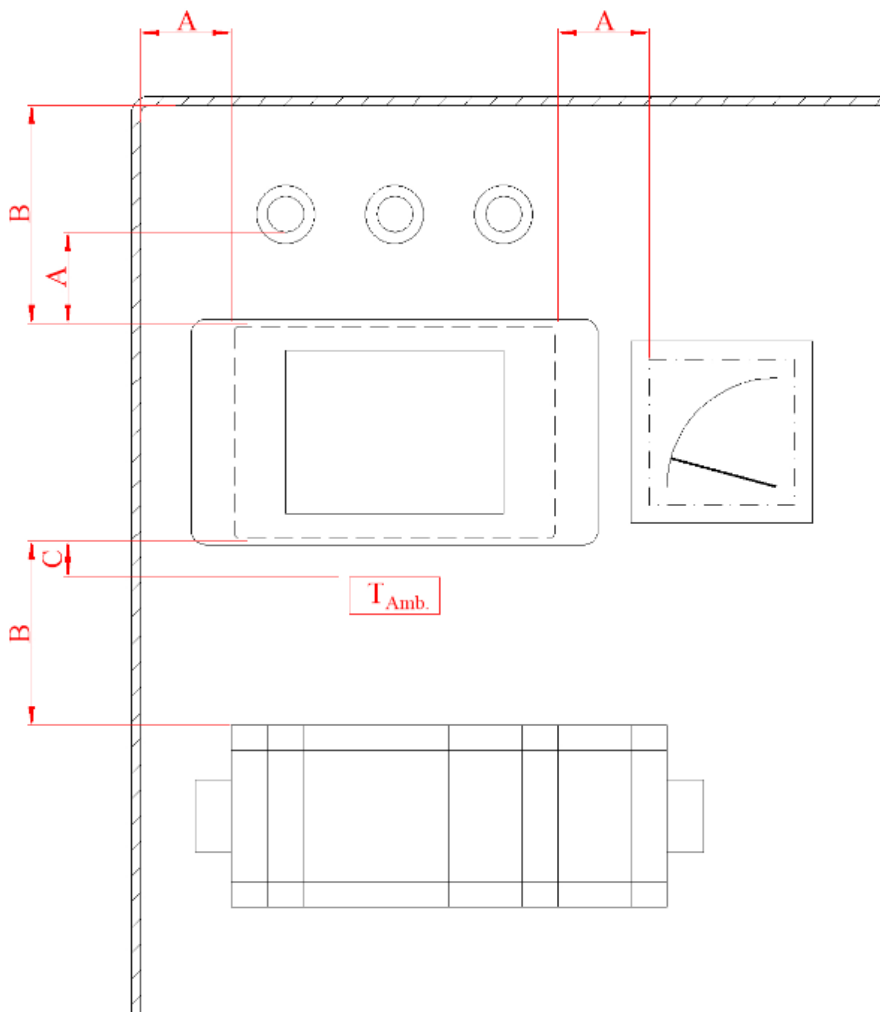

- A: Clearance at sides or to small parts above or below. > 50mm / 2"**
- B: Clearance at top or bottom to cabinet or large parts. > 100mm / 4"**
- C: Position for ambient temperature measurement. 25mm / 1"**

2.4 Dimensions

Wall Mount

The dimensions of the wall mount fixing holes are as detailed as below:

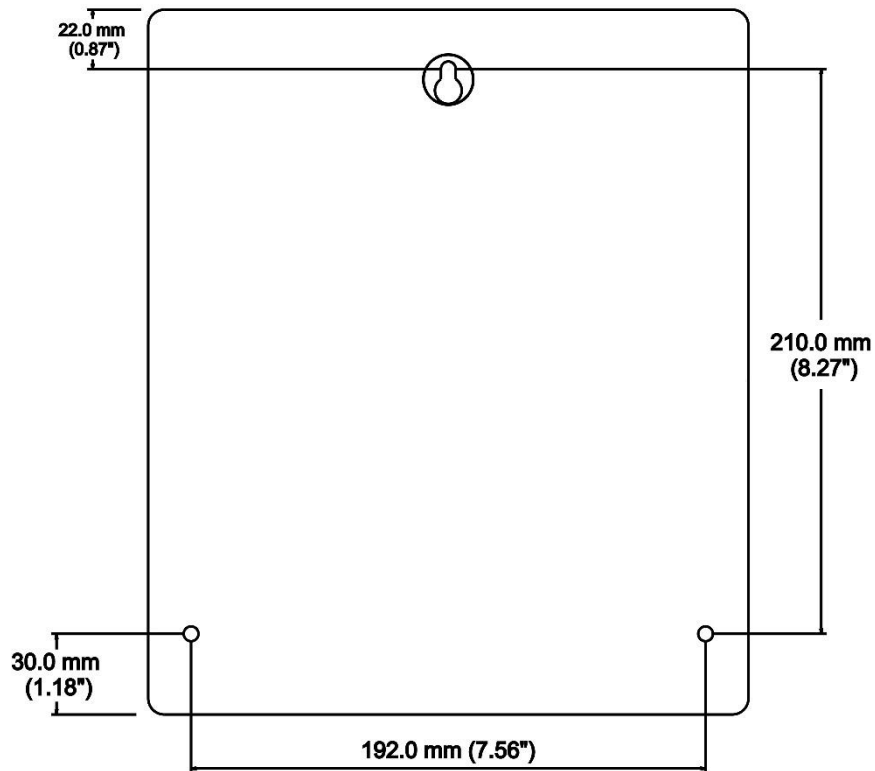

The Ultimate wall mount should be mounted by drilling three holes suitable for size 8 screws (length to suit application) and fixing the top screw in place. Hang the Ultimate on this screw and fix the two remaining screws by removing the terminal cover, on the front of the unit, to gain access to the pre-drilled holes.

The full dimensions of the wall mount enclosure are as shown below:

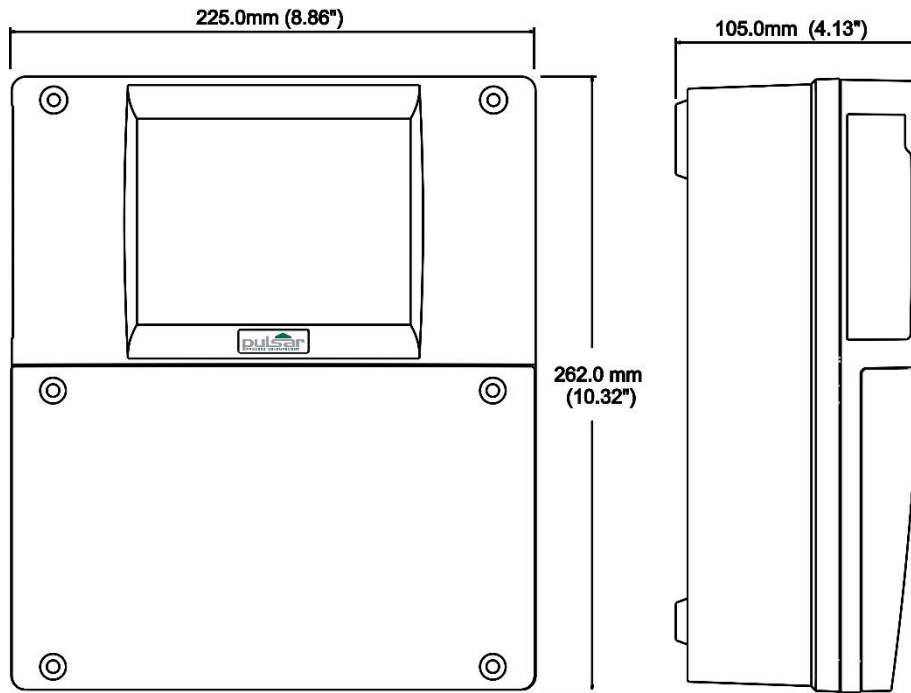

Cable Entry

There are 11 cable gland knockouts on the underside (base) of the Ultimate wall mount, 9 x M20 and 2 x M16. Select which ones you wish to take out and remove them by using a circular cutter, such as a tank cutter. Care should be taken not to damage the circuit board inside whilst undertaking this. Do not use a hammer, as this may cause damage to the enclosure.

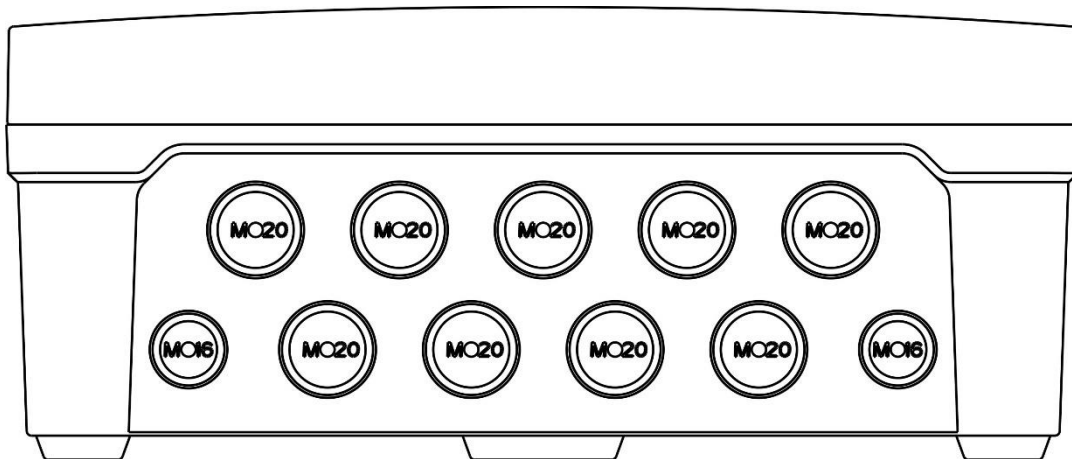

Fascia Mount

The Ultimate should be installed by cutting a hole in the panel as detailed below:

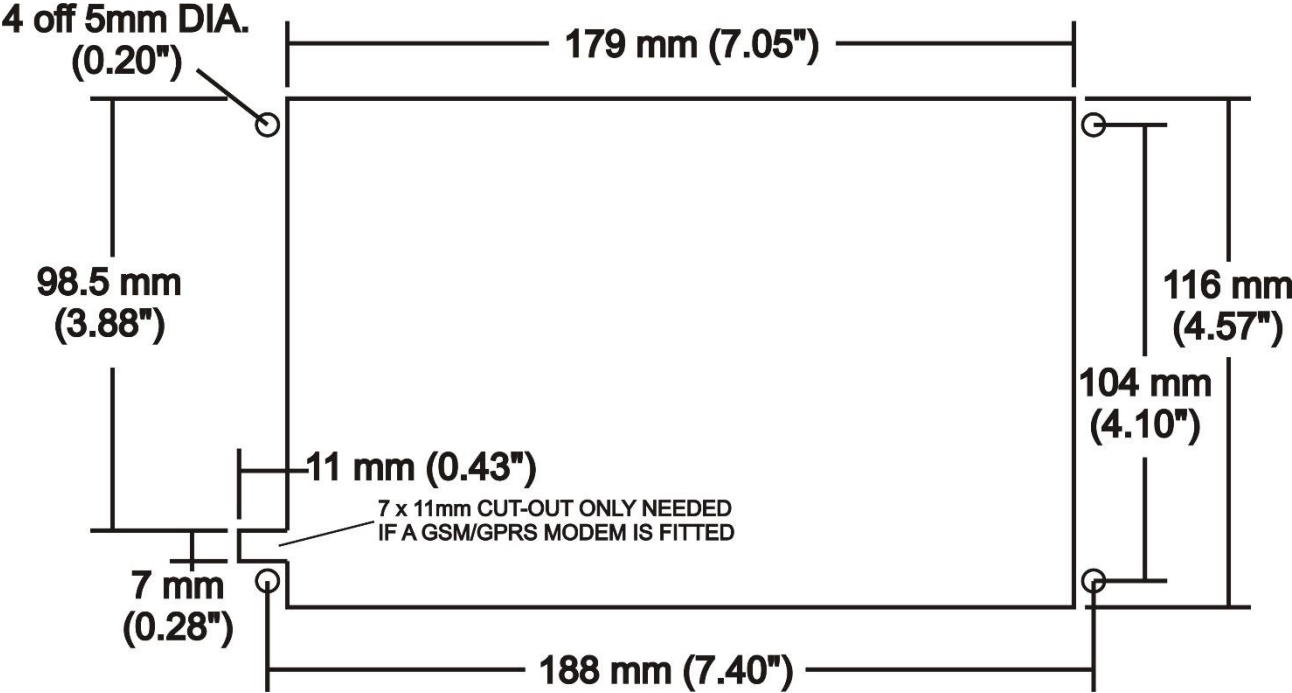

The full dimensions of the enclosure are as shown below:

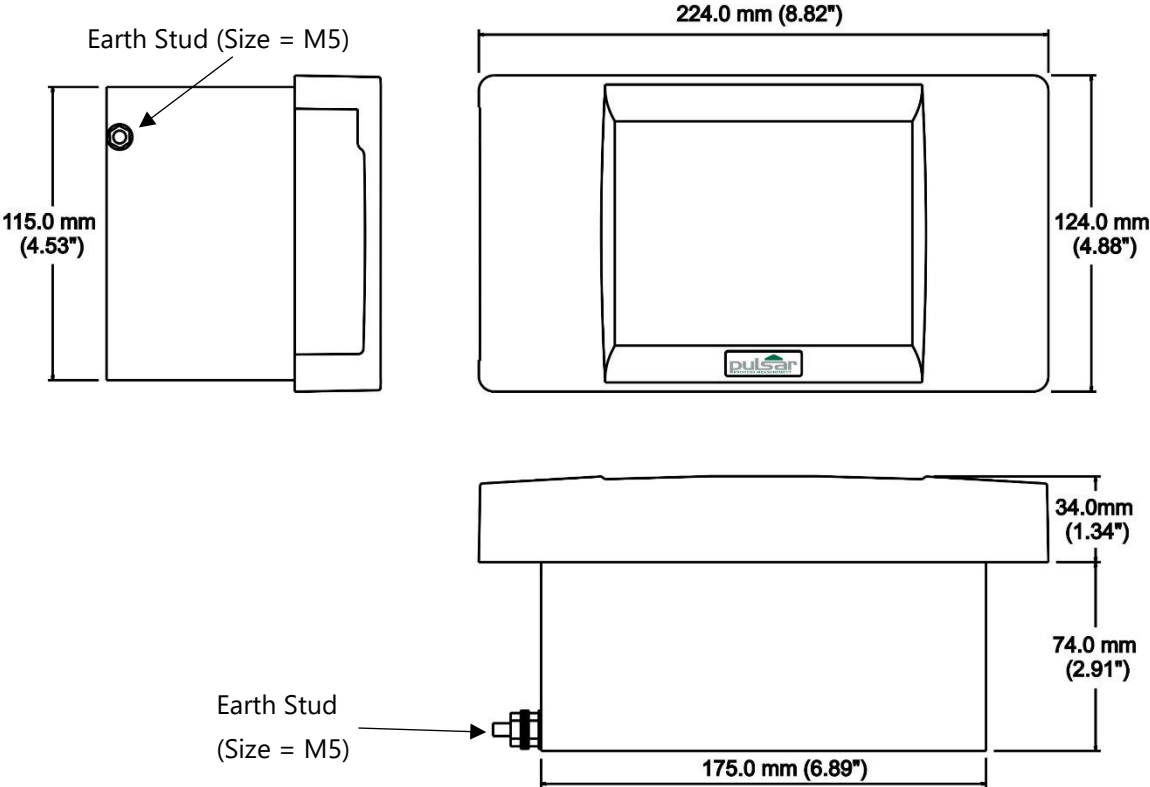

Fascia Mount

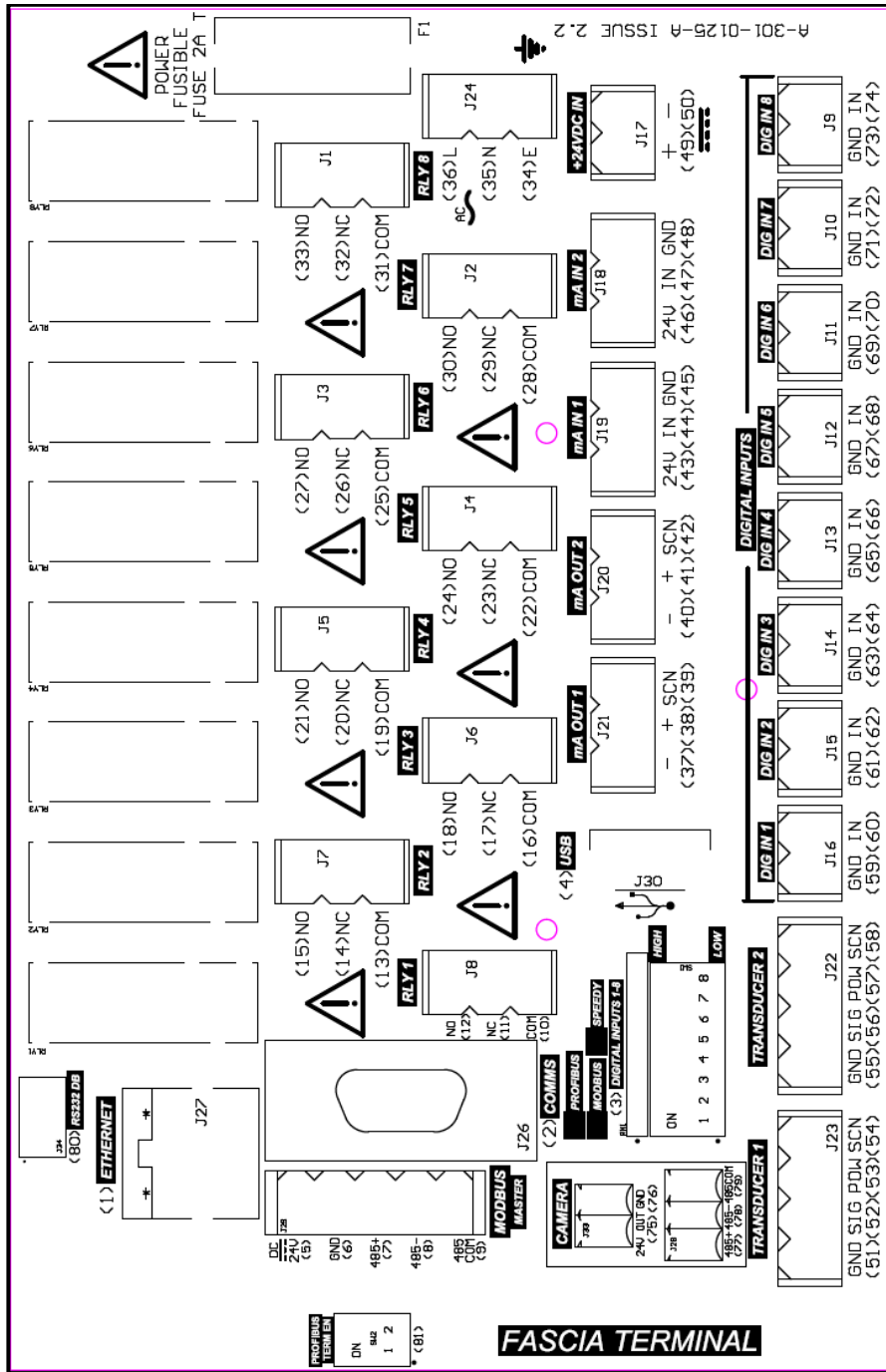

Power

The Ultimate can operate from mains AC and automatically from DC or battery backup in the event of power failure or can be operated permanently from DC or batteries.

Transducers

The transducer should be installed, and connected, in accordance with the installation instructions contained in the Transducer User Guide.

Wire the transducer to the Ultimate transducer terminals, as follows:

Transducer 1

FASCIA UNIT			
TERMINAL CONNECTION DETAILS			
Black	White	Red	Green
0 Volts	Signal	Power	Screen
51	52	53	54

WALL UNIT			
TERMINAL CONNECTION DETAILS			
Black	White	Red	Green
0 Volts	Signal	Power	Screen
67	68	69	70

Transducer 2

FASCIA UNIT			
TERMINAL CONNECTION DETAILS			
Black	White	Red	Green
0 Volts	Signal	Power	Screen
55	56	57	58

WALL UNIT			
TERMINAL CONNECTION DETAILS			
Black	White	Red	Green
0 Volts	Signal	Power	Screen
67	68	69	70

When using 2-core screened extension cable, the Black and Green wires of the transducer should be connected to the screen of the extension cable, which in turn should be connected to the appropriate 0-volt terminal of the Ultimate.

Atex & IECEx

For **Ex m (Zone 1)** applications the correct transducer must be used (please consult your local Pulsar distributor for assistance), and must be supplied via a 4000A breaking fuse, which is fitted as standard to the Ultimate.

For **Ex ia (Zone 0)** applications the correct transducer must be used (please consult your local Pulsar distributor for assistance), which must be connected to the Ultimate via an external Zener barrier.

FM

For **AEx m (Class 1, Zone 1)** applications a transducer certified to **FM Class I Div. 1 Group A, B, C & D, ClassII Div. 1 Group E, F & G, Class III** is used, and must be supplied via a 1500A breaking fuse, which is fitted as standard to the Ultimate.

Restrictions of use: Do not use in the presence of these groups of Chemicals - Aliphatic Hydro Carbons, Ketones or Esters

For **AEx ia (I.S.)** a transducer certified to **FM Class I Div. 1 Group A, B, C & D, ClassII Div. 1 Group E, F & G** is used, which must be connected to the Ultimate via an external Zener barrier. See transducer label for certification details.

Wire/Cable ratings & sizes

CONNECTOR	RATING	WIRE SIZE, MIN	WIRE SIZE, MAX
Power, AC	240V 4A min.	0.5mm ² / 20AWG	2.5mm ² / 12AWG
Power, DC	30V 5A min.	1mm ² / 18AWG	2.5mm ² / 12AWG
Relays	For max. rated 240V 5A use 1mm ² / 18AWG min.	Depends on load.	2.5mm ² / 12AWG
Transducers	30V 0.2A min. Standard cable is 0.5mm ² / 20AWG.	0.2mm ² / 30AWG	2.5mm ² / 12AWG
PBUS, DC	30V 4A min.	0.5mm ² / 20AWG	2.5mm ² / 12AWG
Camera, DC	30V 1A min.	0.2mm ² / 30AWG	2.5mm ² / 12AWG
Other terminals	Signal & control; low voltage & current.	0.2mm ² / 30AWG	2.5mm ² / 12AWG

Warning for cable temperature rating: Where ambient temperatures are expected to exceed 40°C, ensure that the wiring is rated for the elevated operating temperature when carrying normal and possible abnormal currents.

Relay Outputs

The eight relays can be programmed for a variety of alarms, pump control, or other process functions. The relay contacts are all rated at 5A at 240V AC. All connections should be such that the short circuit capacity of the circuits to which they are connected, is limited by fuses rated so that they do not exceed the relay rating.

Current Outputs

These are isolated (floating) mA outputs (to 150 V), of 4 - 20mA or 0 - 20mA and the load should not exceed 1K Ω .

Current Inputs

The current input is 4 - 20mA or 0 -20mA sink or source, user programmable and adjustable.

Digital Inputs

Where the Ultimate is required to provide power for a Device Input the appropriate Digital Input dip switch should be in the ON position. (TOTAL maximum current available, for all eight digital inputs, from the 24VDC supply is 24mA). When Device Inputs are self-powered, the appropriate Digital Input dip switch should be in the OFF position. (Min Input voltage 5VDC, and Maximum Input voltage 30VDC with a maximum current of 3mA).

The Digital Input power switches all contained within a red block of dip identified as '(3) Digital Inputs 1 - 8' and located as follows:

Wall Mount – to the right-hand side of the connector board above Transducer 1 terminals.

Fascia Mount – to the left-hand side of the connector board above Transducer 2 terminals.

2.6 Fuse Location

Wall Mount

The mains fuse is located within the wiring compartment towards the bottom left hand side of the unit, as illustrated below.

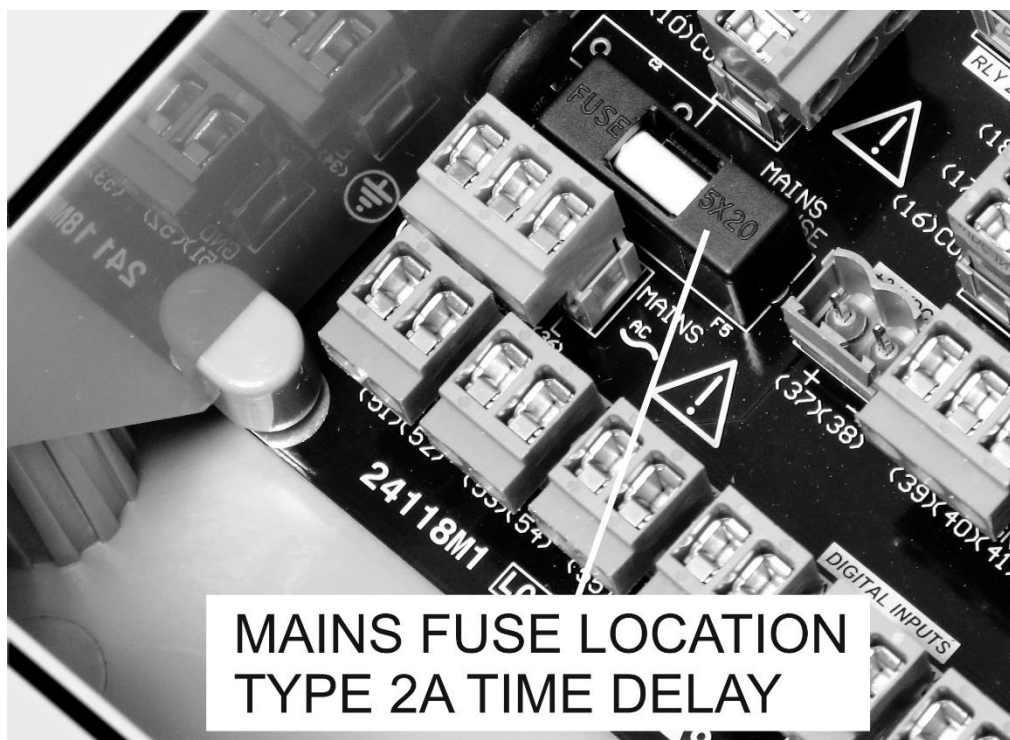

Fascia Mount

The mains fuse is located on the right-hand side just below the earth stud.

Important Information

The rear metal case of the fascia unit must be connected to earth via the earthing stud located on the rear of the unit, see drawing on page 11, using wiring to meet local requirements.

For both Wall & Fascia units an external isolation switch or circuit breaker should be installed, in an accessible location and labelled to identify the equipment, near to the Ultimate to allow the supply to be removed during installation and maintenance. The isolation switch must be rated according to local regulations and supply voltage, 100V or 240V AC and $\geq 4A$. In addition, the relay contacts should also have a means of isolating them from the unit.

Interconnecting cables must be adequately insulated in accordance with local regulations. Strip back 30 mm of the outer insulation of the cable. Strip 5 mm of insulation from the end of each conductor. Twist all exposed strands of the conductor together. Insert the stripped conductor into the terminal block as far as it will go and tighten the terminal block screw. Ensure that all strands are firmly clamped in the terminal block and that there is no excess bare conductor showing, and no stray strands.

Important Information

If the equipment is installed or used in a manner not specified in this manual, then the protection provided by the equipment may be impaired.

2.7 Preparation for Operation

Before switching on, check the following:

- The Ultimate is mounted correctly and is in a 'safe' area.
- The power supply is correctly installed.
- The I/O, relays and any peripherals are connected correctly.
- Ensure any controlled equipment, e.g., valves, servos & motors, can operate without danger to people or property.

2.8 Maintenance

There are no user serviceable parts inside your Ultimate, except the mains fuse. If you experience any problems with the unit, then please contact Pulsar Process Measurement for advice.

To clean the equipment, wipe with a damp cloth. Do not use any solvents on the enclosure or front panel.

Important Information

The unique DATEM software comes into operation as soon as power is applied and is designed to monitor a **moving level** or **target** with the **transducer** in a **fixed position**.

If, after any period of use, it should become necessary to move the transducer, for any reason, from its original operating position, switch off the **Ultimate**, before proceeding, to prevent any undesirable updates to the **DATEM** trace. If after moving the transducer the reading is not as expected, please refer to **Chapter 8 Troubleshooting**.

2.9 RS485 Connectivity

There are several peripheral devices that can be connected to the Ultimate. Connection of these devices to the Controller and the location of the terminals are shown later in this section.

The following Pulsar products can be connected to the Ultimate Controller:

PBUS Modbus master (RS485 Terminals)

- MicroFlow velocity sensor.
- Power Monitor.
- Pulsar’s I/O Interface module.
- FlowPulse.
- Camera (3 and 2 pin mini terminals)
- Pulsar’s Input expansion unit.

D-Type Connector

- Speedy velocity sensor.
- Connection of optional Modbus or Profibus comms.

The configuration of this connector must be specified at the time of ordering. (The connector shell is floating ground for Profibus but is local 0V for Speedy).

A diagram of the pin layout for the D-Type connector can be seen below:

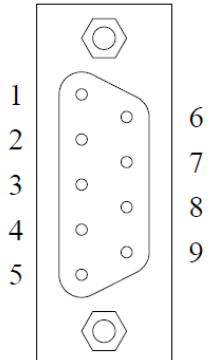
Ultimate builds:			Function;		
			Speedy (Modbus): Non-isolated	Profibus: Isolated	
Fascia terminal;		1 2 3 4 5	6 7 8 9	Pin:	
Speedy	Profibus			1	0V / supply GND.
F7 350mA	F7 NF			2	N.C.
R5 not fitted.				3	RS485+
R6 not fitted.		4	N.C.		
Wall-mount;		5	0V (Comms card)		
Speedy	Profibus	6	+5V (Comms card)		
F11 350mA	F11 NF	7	N.C.		
R73 not fitted.		8	RS485-		
R74 not fitted.		9	+24V supply	N.C.	
		Shell	N.C. (0V / GND)	N.C. (cable shield)	

D-sub socket (Top view)

Wall Mount

The RS485 terminal, Digital Input switches (The ON position uses a pull-up resistor to keep the input high. The change in state will occur when the input is connected to ground. The OFF position is used when an external DC voltage is used to change the input state), camera terminal and D-type connection is located on the top right-hand side of the unit as illustrated below:

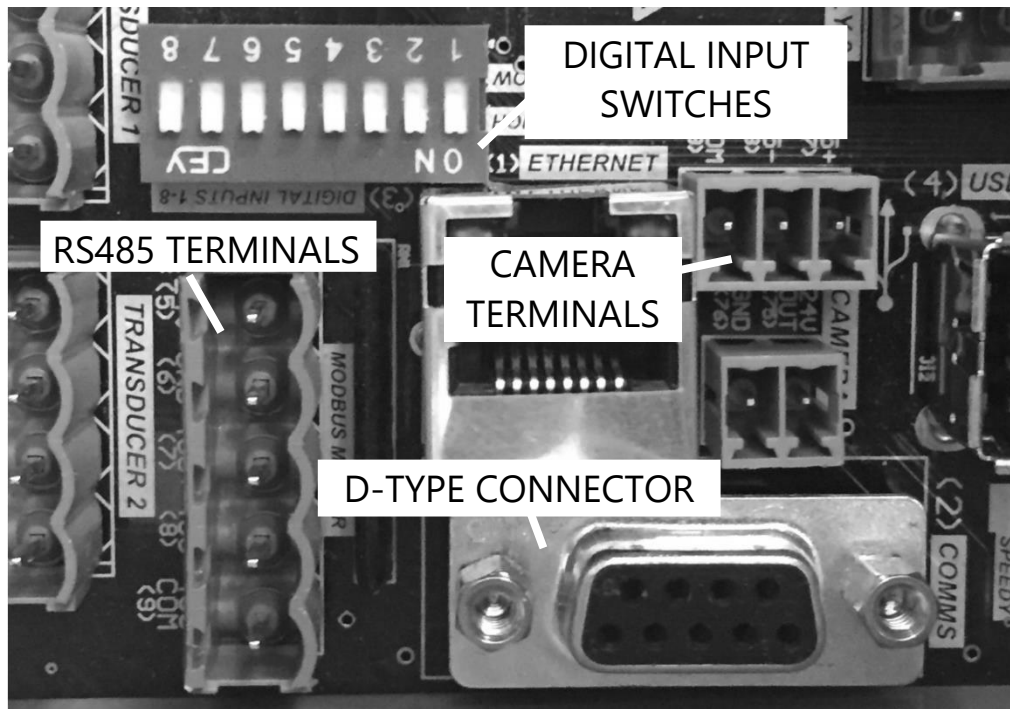

Fascia Mount

The RS485 terminal, Digital Input switches, camera terminal and D-type connection is located on the left-hand side of the unit as illustrated below:

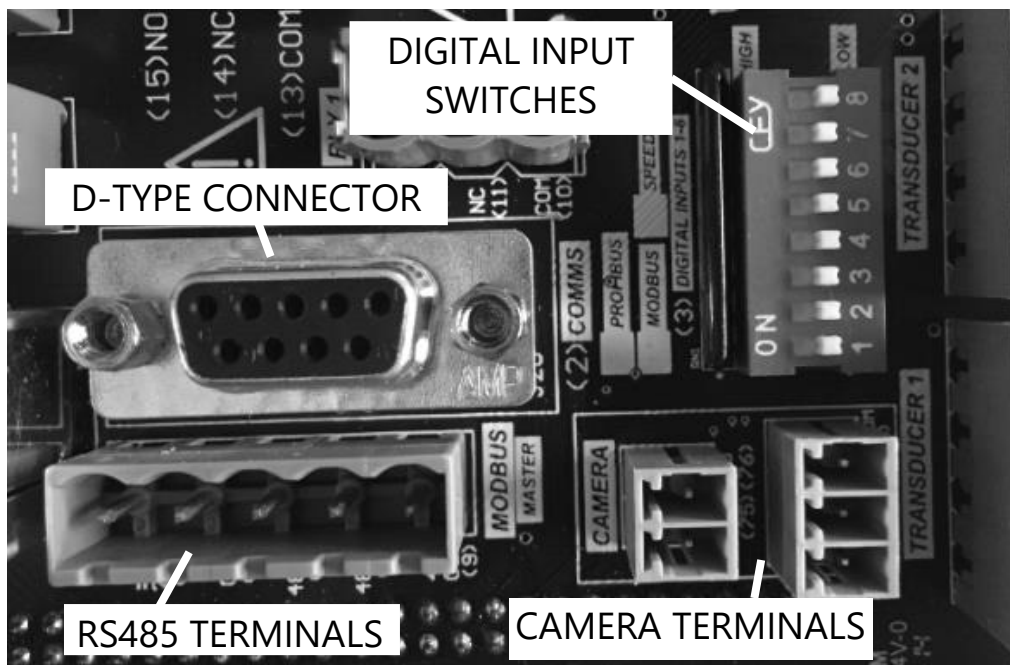

Important Information

For further information on the devices that can connect to the Ultimate Controller. Please refer to the separate **Ultimate Peripherals Manual**.

CHAPTER 3 HOW TO USE YOUR ULTIMATE PUMP CONTROLLER

3.1 Run Mode

This mode is used once the Ultimate has been set up in program mode. It is also the default mode that the unit will assume on initial power up or when resuming operation after a power failure. During Run Mode the display will show the value of the principal process variable being monitored along with a bar graph showing the percentage value of the principal process variable.

When the Ultimate is switched on for the first time, it will display, in metres, the distance from the face of transducer 1 to the target. All relays by default are switched off.

Main Display

The 5.7-inch colour TFT display with capacitive touch screen is used to provide information on the current mode of operation, and status of alarms, pumps and other programmed features. The display also provides the method for programming the Ultimate to the desired application, through a structured menu system.

Initial Display

On initial powering up the Ultimate controller you will see a screen like the following display.



Once the Ultimate has been set up for an application, the display can be configured to show additional information about the application and which features are in use. An example is shown below.

Level / Volume Display



When the Ultimate has been setup for a differential application, the display will be configured to show the two levels like the example shown below:

Differential Level Display

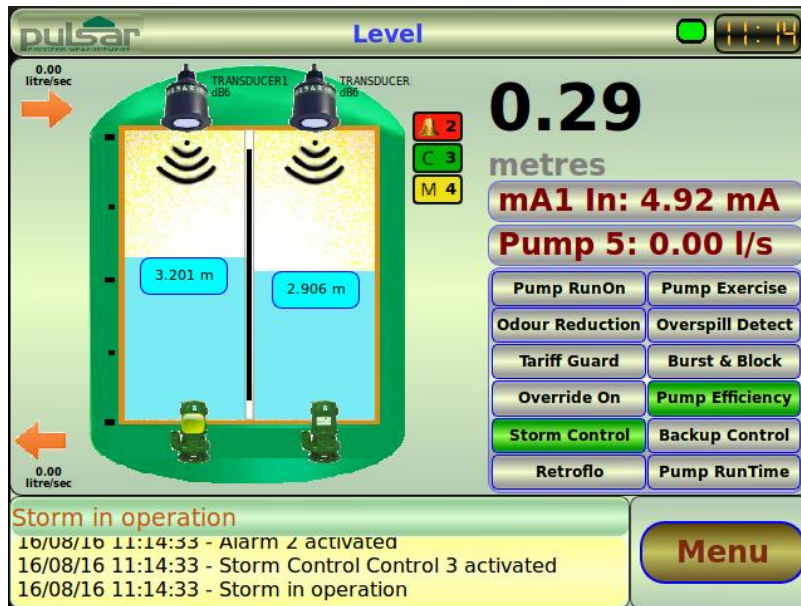

When the Ultimate has been set up for an OCM application, the display can be configured to show the type of PMD selected, and additional information such as any MicroFlow / Speedy velocity sensors and current velocity measurements obtained.

OCM Display



Display Icons and Legends

A description of all icons and legends that can be accessed and viewed whilst in Run Mode are detailed below.

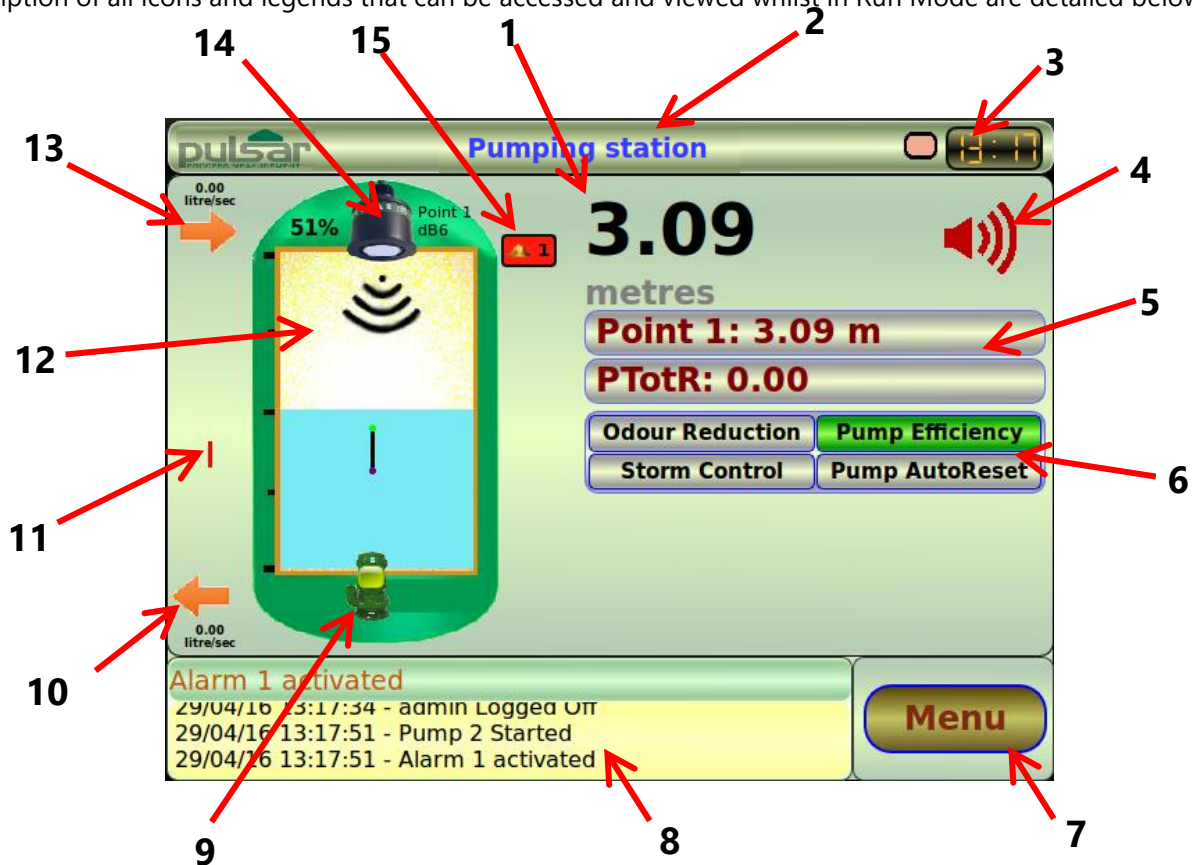

1. **Principle Measurement Variable:** This variable is also used for determining the display of the bar graph.
2. **Application Name:** Can be assigned during application set up.
3. **Time:** Displays the current time.
4. **Audible alarm symbol:** This is displayed when an alarm relay has been programmed and the enable audio option is selected to energise when an alarm condition is present. Touching the symbol on the screen will mute the audible sound emitted by the controller.
5. **Auxiliary Display:** Besides the principal measurement variable, up to two other measured variables can be displayed.
6. **Enabled Pump Advanced Features:** This shows which Pump Advanced features are enabled. When the features are in operation, the associated indicators will turn green.
7. **Main Menu button:** Provides access to the program mode to configure the Ultimate controller to the required application.
8. **Event log:** Date and time stamped log of the previous 300 I/O events, it will also show any modules that have been added.
9. **Pump status and set point indicators:** Shows the status of the pump and duty level set point in relation to the bar graph for each pump.
10. **Pumped Flow indicator:** This indicator provides a pumped flow rate figure for the application.
11. **Level alarm set point indicator:** Displays alarm level set points in relation to the bar graph level.
12. **Level Bar Graph:** Shows the percentage value of the principal measurement variable.
13. **Inflow Indicator:** Provides indication of rate of flow into the well.
14. **dB transducer diagnostics:** Provides access to transducer echo profiles and allows adjustments to be made, if required. This icon will turn red when there is a failed safe condition.
15. **Relay indicators:** indicates the state of all programmed relays which are not pumps. For alarms, the indicator will turn RED in the alarm condition, green if active for control and miscellaneous relay types.

Differential Display Icons and Legends

A description of all icons and legends that can be accessed and viewed when a differential application is displayed, whilst in Run Mode are detailed below.

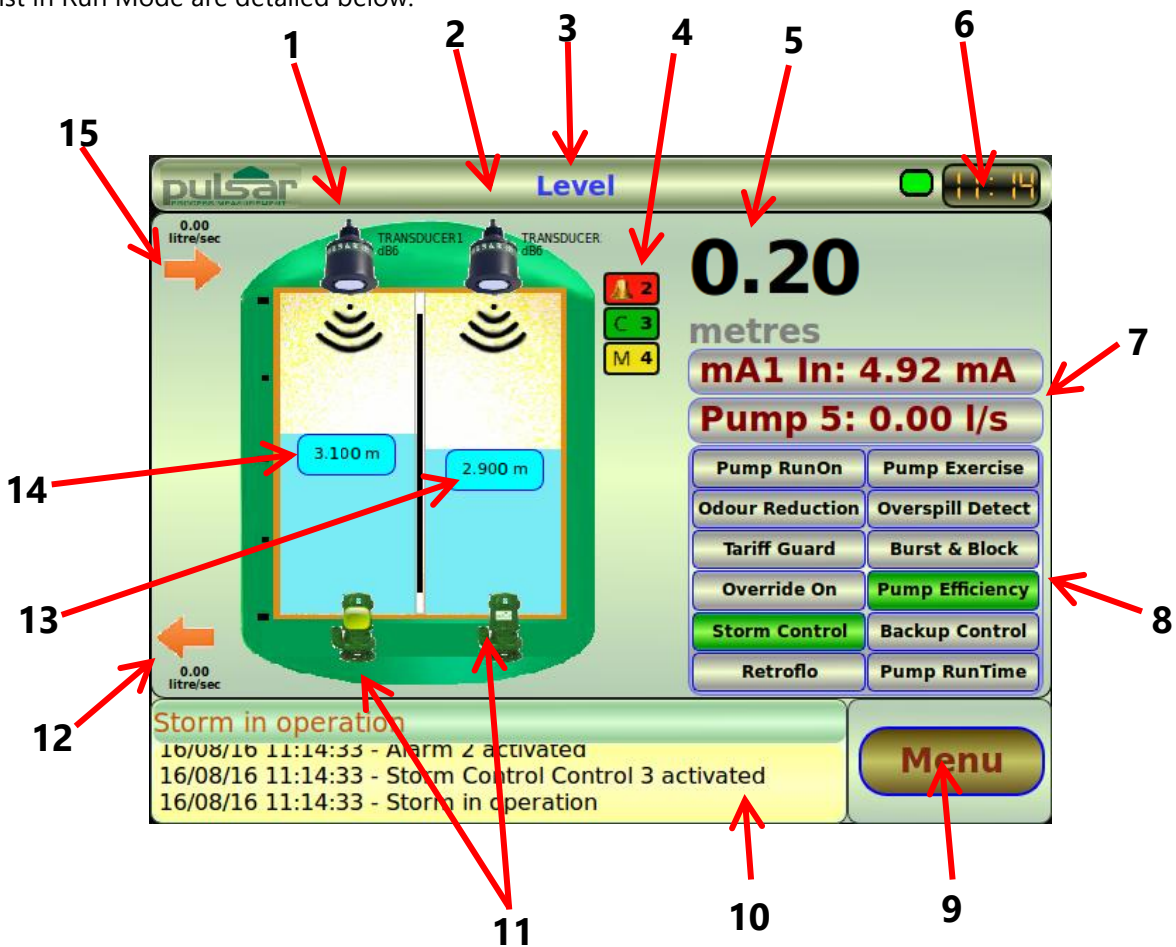

1. **Upstream Transducer:** Provides access to the Upstream transducer echo profiles, and allows adjustments to be made, if required. This icon will turn red when there is a failed safe condition.
2. **Downstream Transducer:** Provides access to the Downstream transducer echo profiles, and allows adjustments to be made, if required. This icon will turn red when there is a failed safe condition.
3. **Application Name:** Can be assigned during application set up.
4. **Relay indicators:** indicates the state of all programmed relays which are not pumps. For alarms, the indicator will turn RED in the alarm condition, green if active for control and miscellaneous relay types.
5. **Principle Measurement Variable:** This variable is used for determining the display in difference of the levels of the application.
6. **Time:** Displays the current time.
7. **Auxiliary Display:** Besides the principal measurement variable, up to two other measured variables can be displayed.
8. **Enabled Pump Advanced Features:** This shows which Pump Advanced features are enabled. When the features are in operation, the associated indicators will turn green.
9. **Main Menu button:** Provides access to the program mode to configure the Ultimate controller to the required application.
10. **Event log:** Date and time stamped log of the previous 300 I/O events, it will also show any modules that have been added.
11. **Pump status:** Shows the status of the pump and provides access to the duty and level set point in relation to each pump.
12. **Pumped Flow indicator:** This indicator provides a pumped flow rate figure for the application.
13. **Downstream Level:** This displays the current level of the downstream vessel in measurement units.
14. **Upstream Level:** This displays the current level of the upstream vessel in measurement units.
16. **Inflow Indicator:** Provides indication of rate of flow into the vessel.

OCM Display Icons and Legends

A description of all icons and legends that can be accessed and viewed when an OCM application is displayed, whilst in Run Mode are detailed below:

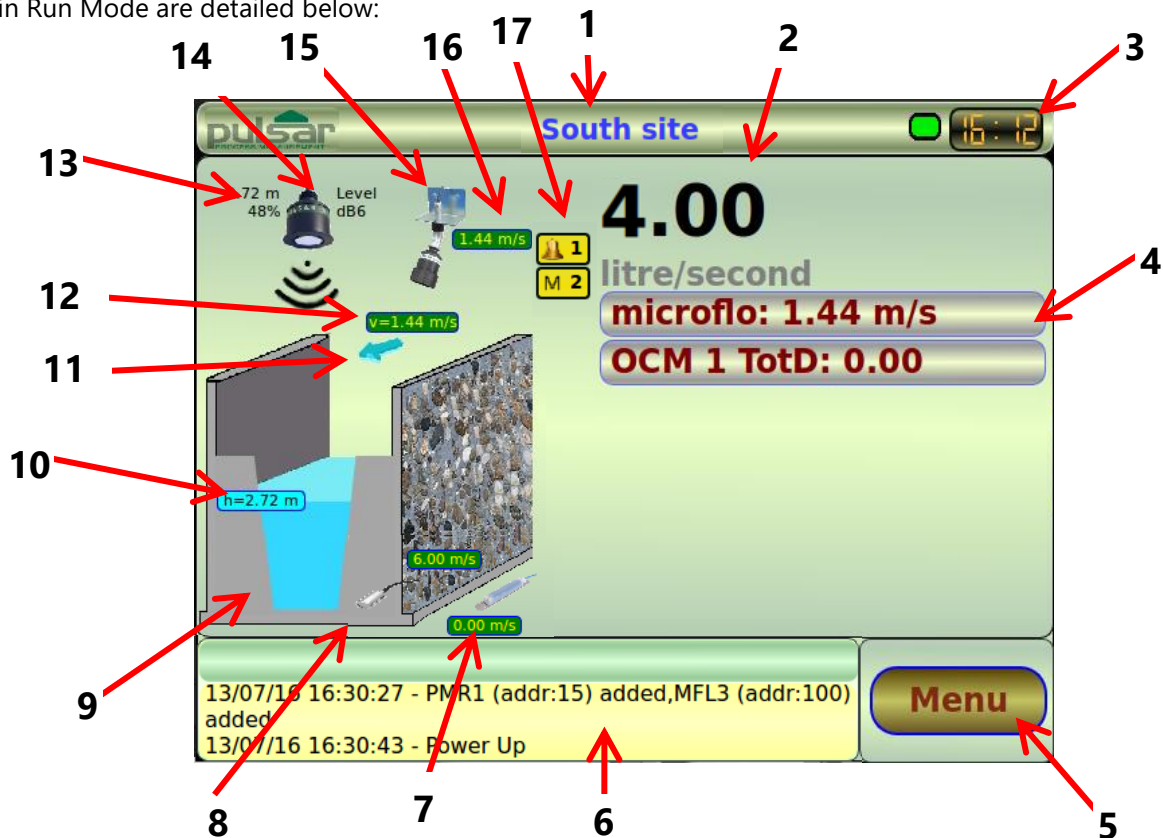

1. **Application Name:** Can be assigned during application setup.
2. **Principle Measurement Variable:** This displays the current flow reading in **measurement units**.
3. **Time:** Displays the current time.
4. **Auxiliary Display:** Besides the principal measurement variable, up to two other measured variables can be displayed.
5. **Main Menu button:** Provides access to the program mode to configure the Ultimate controller to the required application.
6. **Event log:** Date and time stamped log of the previous 300 I/O events, it will also show any modules that have been added.
7. **Speedy sensor:** Displays current velocity of a speedy sensor if allocated to the OCM application.
8. **Velocity Sensor (mA input):** Displays current velocity of a velocity sensor via mA Input, if allocated to the OCM application.
9. **PMD:** Selected OCM display source's PMD is displayed.
10. **Level Display:** Displays the current level of the PMD in **measurement units**, as measured by the transducer.
11. **Movement of Flow:** Arrow shows the direction of flow/velocity that is being measured by a sensor.
12. **Velocity Measurement:** This displays the current velocity of all velocity sensors that are allocated with the OCM application displayed. If multiple sensors are used and 'Differential', 'Average' or 'Sum' is selected, the value will be shown here.
13. **Level Indicator:** Shows the percentage value and current level of the PMD, as measured by the transducer.
14. **dB transducer diagnostics:** Provides access to transducer echo profiles and allows adjustments to be made, if required. This icon will turn red when there is a failed safe condition.
15. **MicroFlow sensor diagnostics:** Provides access to MicroFlow trace screen and allows adjustments to be made, if required.
16. **MicroFlow Velocity:** Displays current velocity reading of all MicroFlow sensors allocated to the OCM application displayed.
17. **Relay indicators:** indicates the state of all programmed relays which are not pumps. For alarms, the indicator will turn RED in the alarm condition, green if active for control and miscellaneous relay types.

Extended information screens

From the main run mode screen, there are several "active" areas on the touch screen that will give more information about that specific item. Using these screens will not halt any measurements or change any of the application settings within the controller.







Hot key banner

A - Provides a set of buttons to view totaliser, I/O, and diagnostics information.



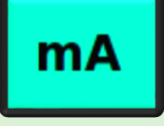



HOT KEY	FUNCTION
	Show camera image (if camera module connected)
	Shows the status of Digital inputs and Relay outputs. Useful for verifying digital input signals.
	For applications including open channel flow measurement, this will show the System, Resettable, and daily totaliser values.
	If the pumped volume feature is enabled, this will show the system, resettable, and daily totaliser values.

HOT KEY	FUNCTION
	Displays distance, level, rate, echo confidence, echo strength, H.A.L.L., average noise, peak noise and temperature for each dB transducer connected.
	Displays individual pump information such as number of starts, total run time, total volume pumped, and kWh used.
	Displays the current mA input and output values.
	Displays system information such as serial number, firmware and hardware revisions.

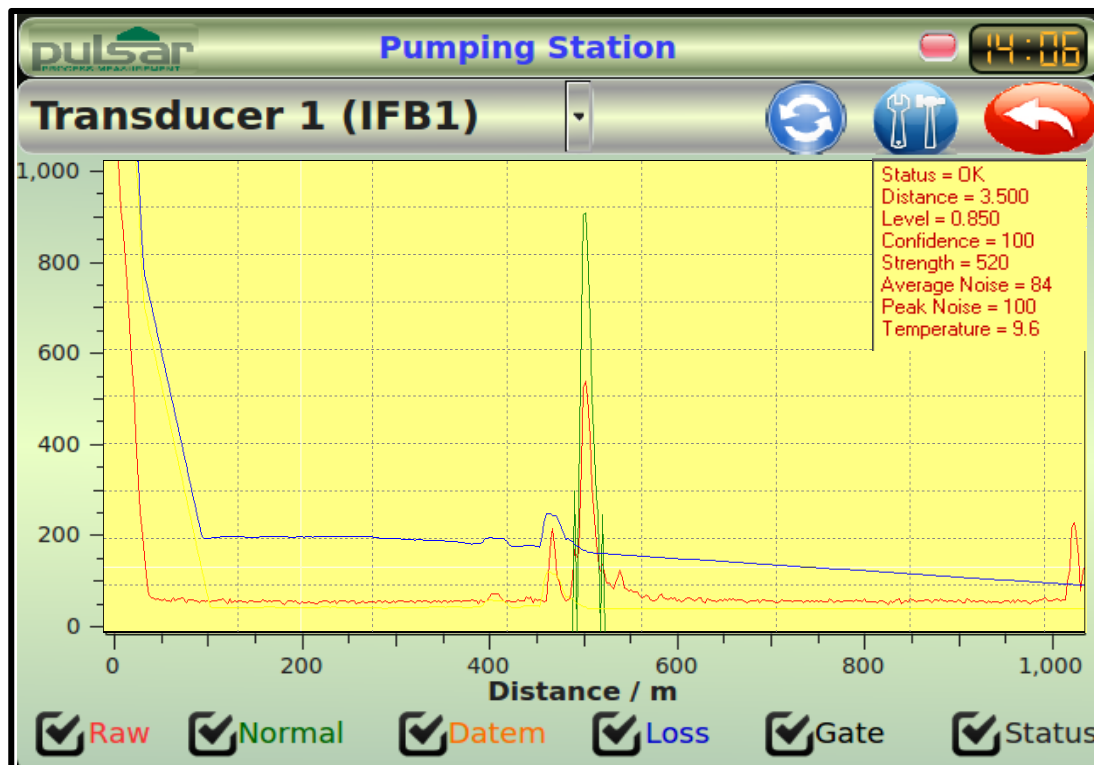
Transducer diagnostic traces

B – This screen will display the echo traces from any active dB transducers. Select between the transducers by using the dropdown list at the top of the screen. The checkboxes select which traces are shown. Touching an area on the echo trace graph will show that point as a coordinate of signal strength and distance.



BUTTON	FUNCTION
	Momentarily bypasses damping and updates the measurement to the current echo trace.
	Allows access to echo algorithm adjustment parameters via a service passcode.
	Back - Returns to the main run mode screen.

Relay information

C - The Relay information screen gives more detail about programmed Alarm, Control, and Miscellaneous relays. Information includes relay name, setpoints and number of closures and failsafe settings. A Bar graph of the main measurement variable is given on the right-hand side of the screen.

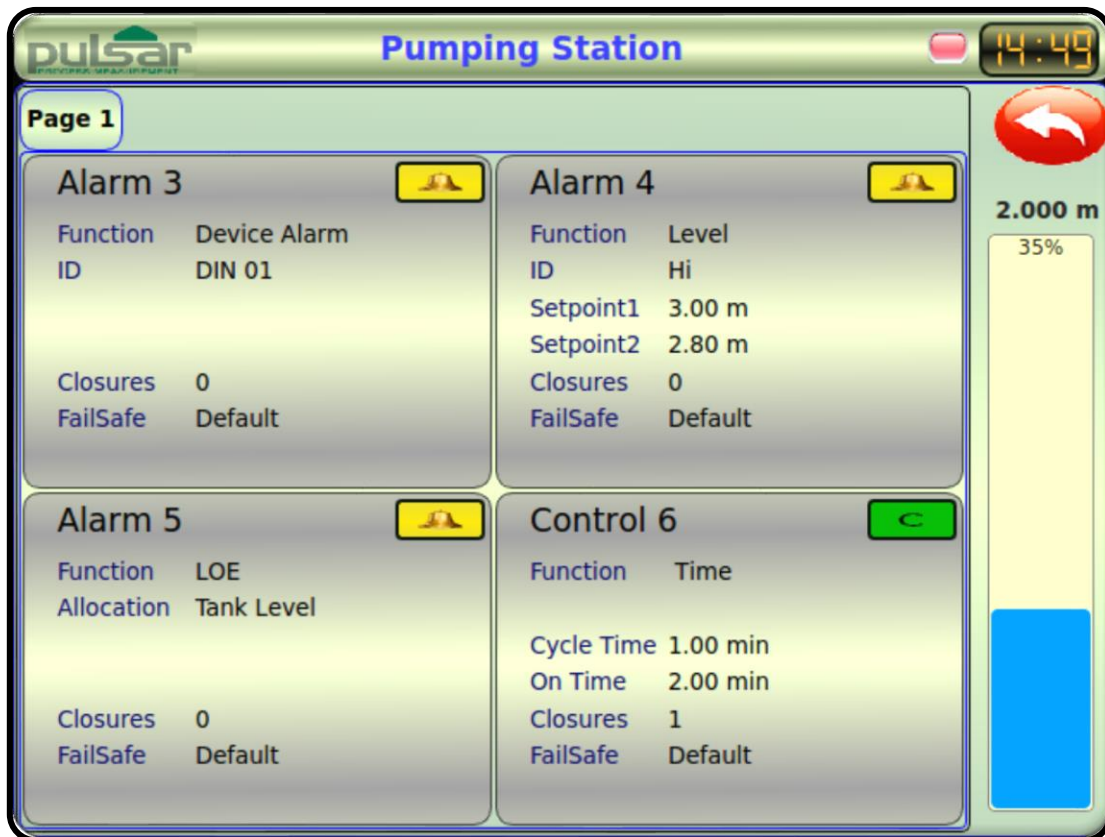

Trend View

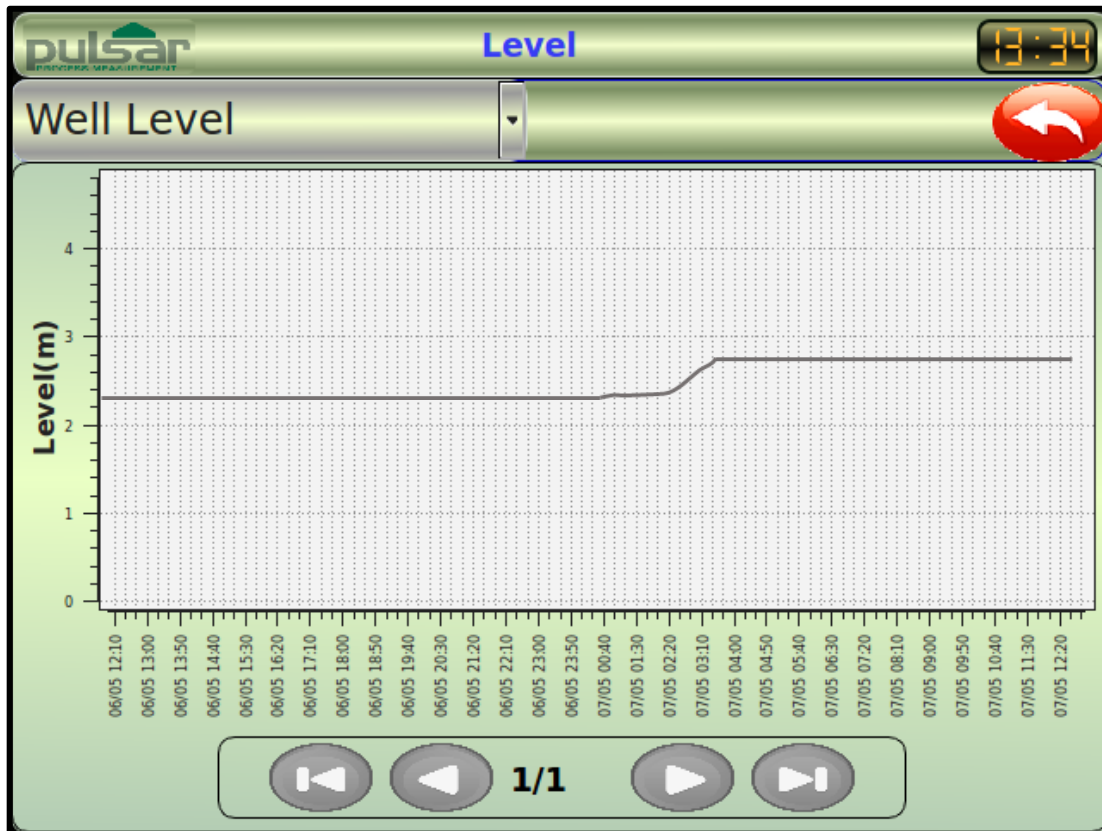

D – The Ultimate will automatically trend all measurements used in an application setup. The sample frequency is user definable in the Advanced Config. → Log Setup menu.

Use the drop-down list at the top of the screen to select the trend to be viewed. Use the arrow keys to view the trend history.

A new trend will be started each time the Ultimate is power cycled, and once a trend has reached 10000 samples, that data is stored as a file to memory, and a new trend is started. Trend files can be transferred to the external SD card and are of .CSV format.

Flow Pulse diagnostic trace

E – Where Pulsar Flow Pulse flow monitors are being used, an icon of a Flow Pulse  will be in this position. Selecting this will show the diagnostic trace, strength, and confidence figures for the connected Flow Pulse devices.

Pump Information and manual control

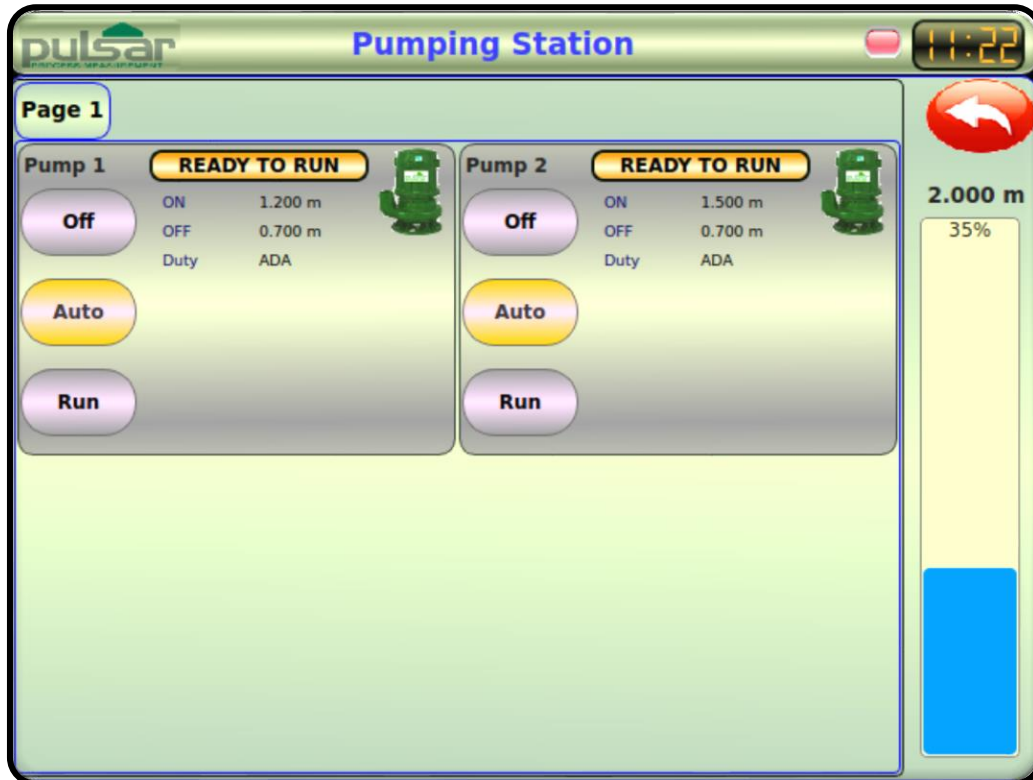

F - This screen gives specific information about the individual pump relay setup. The basic information given is Pump Name, start and stop levels, and pump duty. A bar graph of the main measurement variable is also given on the right of the screen.

If Pulsar **Power Monitors** are connected, the voltage, current, and power factor per phase, and KWh total for the previous/current pump run are also given.

If a Pulsar **Flow Pulse** flow monitor has been assigned to a particular pump relay, then the flow rate will also be displayed.

Manual Pump controls

This screen also provides manual controls for the individual pump relays. The default position is **Auto** – where the operation of the relay is managed by the Ultimate controller from the programmed relay setpoints and Advanced pump features.

Off – overrides the pump relay to the off state. The Pump relay will remain in the off state until it is set to the **Auto**, or **Run** positions. When set to **Off**, the relative pump icon on the main run screen will turn black  and a text warning will be shown indicating the pump is set to manual **Off**.

Run – overrides the pump relay to the on state. The Pump relay will remain in the on state until it is set to the Auto, or off positions. When set to **Run**, the relative pump icon on the main run screen will turn blue  and a text warning will be shown indicating the pump is set to manual Run.

Manual trip counter and Pump demotion reset

In addition to the manual controls, if digital inputs are being used to monitor pump failures/trips, or if feature has been enabled which can **demote** a pump. Selecting the pump icon for an individual pump will provide pump trip counter information, and controls to reset the counter/demotion.

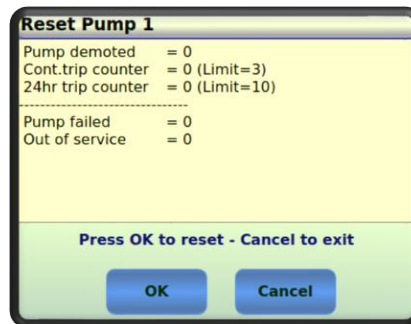
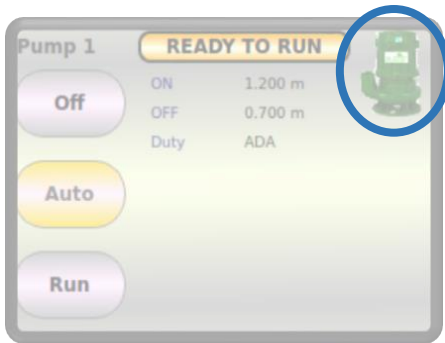

Event log

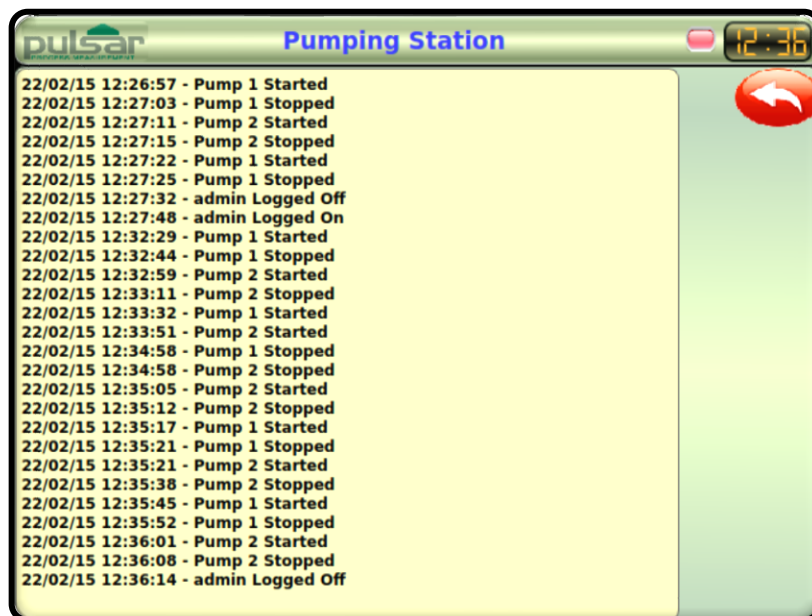

G – Provides a scrollable list to view the 300 most recent system events. Each event is date and time stamped, and the list is stored in memory which can be transferred to SD card.



Common screens and controls

Throughout the Ultimate controller’s menu system, you will find there are some common buttons and screens for navigation and parameter entry.

Common control buttons

BUTTON	FUNCTION
	Go Back – Return to previous screen
	Information – provides more information about the topic currently shown on the screen

The menu system in Ultimate Controller has control and selection mechanisms commonly found in modern computer windowing systems. These include buttons, scroll bars, checkboxes, radio buttons, tree lists, tables, and dropdown list boxes.

Text entry

Throughout the Ultimate controller, you can assign names of your own choosing to items including input sensors, measurement points, volume profiles, digital inputs and relay outputs. Doing so can tailor the Ultimate controller configuration specifically for a process or application, especially if specific measurements or alarms have a named purpose.

Anywhere you see a line of text within a black box (entry box), that text can be edited.

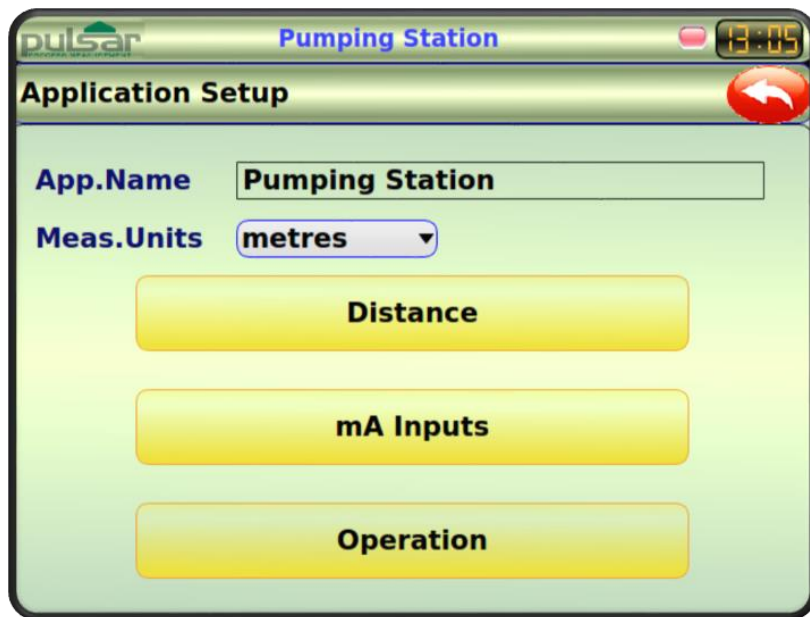

For example, in the setup menu, the App. Name (the text shown in the banner during run mode) can be changed. Just touch the text box next to the App. Name label and the common text entry screen will appear.

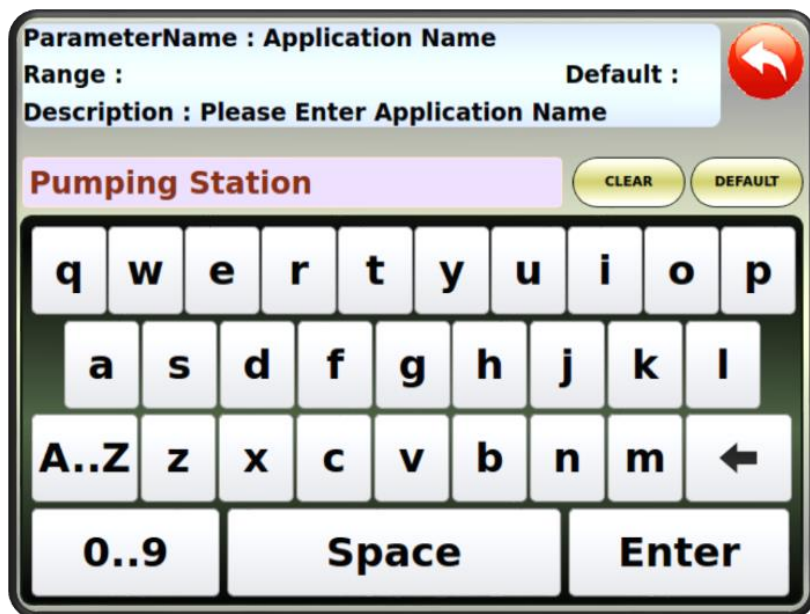

This is a common screen for editing text labels. The box at the top of the screen shows information about the label you are editing. The red text is the current name which can be edited using the alphanumeric keyboard and the clear and default buttons. Press Enter to accept the new text.

Numeric entry

Where changes in numeric parameter values are permitted, the parameter value will be within an entry box (same as text entry). Touching the entry box will open the common numeric entry screen. The box at the top of the screen shows the parameter name, acceptable range of values and default value.

Use the numeric buttons to make the change and press enter to accept the value. Values outside the permitted range will not be accepted.

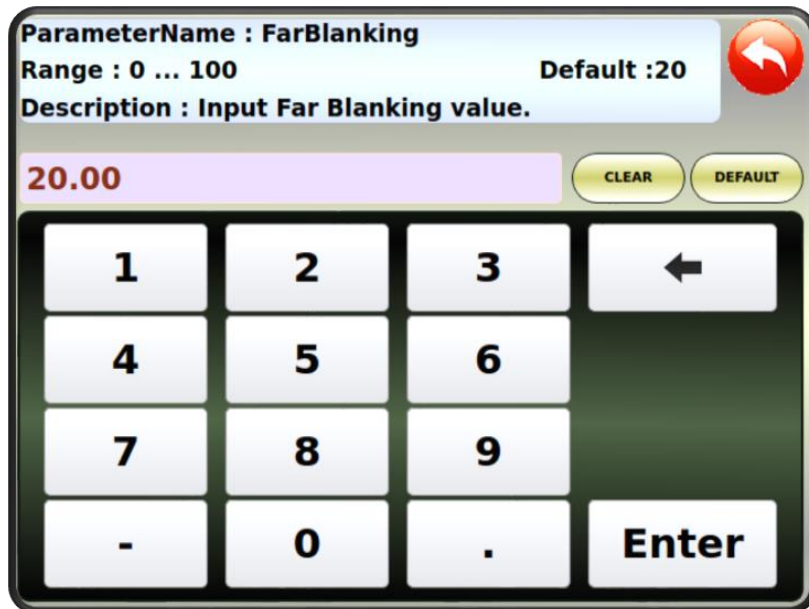

The screenshot shows a numeric entry interface for the parameter 'FarBlanking'. At the top, a light blue header displays the parameter name 'ParameterName : FarBlanking', the range 'Range : 0 ... 100', and the default value 'Default :20'. A red circular arrow icon is in the top right corner. Below the header, a purple input field shows the current value '20.00'. To the right of the input field are two yellow buttons labeled 'CLEAR' and 'DEFAULT'. Below the input field is a numeric keypad with buttons for digits 1-9, a decimal point, a minus sign, and an 'Enter' button. A back arrow button is located to the right of the top row of the keypad.

Operational philosophy

The Ultimate controller can take input variables from a variety of sensor types ranging from the Pulsar dB Ultrasonic transducers to mA input devices. Using the Ultimate controller’s PBUS expansion port, even more sensors and interfaces can be added. The Ultimate Controller also has several outputs ranging from digital communications through to relay and mA outputs. These outputs need to take their operation from a single or combination of measurements provided by the input sensors.

To handle the allocation of input sensors and outputs, the Ultimate utilises a system of **measurement points**. This system declares a value from a sensor as a measurement of a particular type (level, flow, power, temperature...). Each individual measurement point can be specifically named to suit the process it is measuring. Average, sum and differential measurement points can be declared using a number of sensor variables.

The output devices (relays & mA outputs) can then take their operation from a specific measurement point. Volume and OCM conversions are declared in their own menus, and take a measurement point as their input variable.

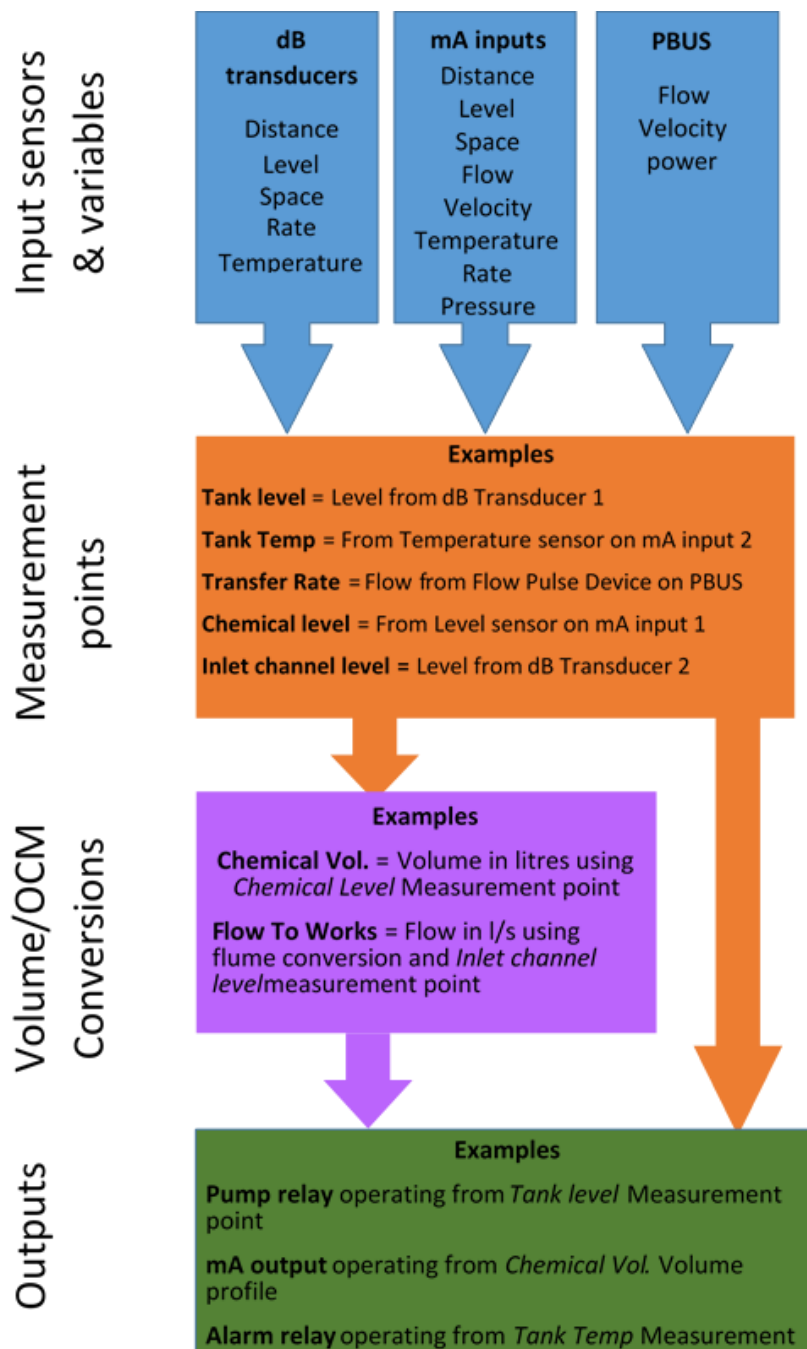

3.2 Program Mode

This mode is used to set up the **Ultimate** or change information already set.

How to Access Program Mode

Touch the  button and an authentication window will appear.

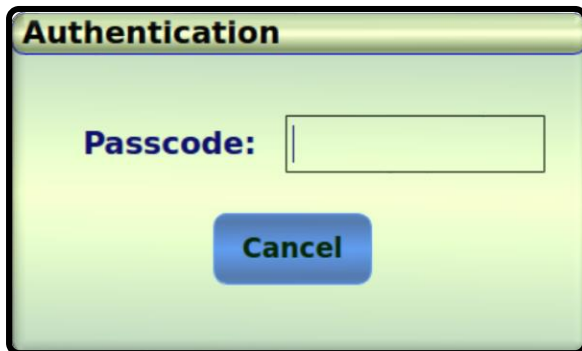

Touch the entry box and enter the following numeric passcode:

1997

This passcode is the default **Administrator** passcode.

Main Menu

Once you have entered the passcode you will see the following screen which contains four sub menus, a brief description of each sub menu can be found below.



Program mode has an adjustable automatic time out of 15 minutes, where the Ultimate will return to run mode if there is no activity.

Setup



The setup menu provides sub menus for controlling the I/O of the Ultimate Controller.



Advanced Config



Advanced Config. Has options for adding Devices on the PBUS port, digital communications configuration, Adding user accounts and general Date/Time, and power settings.



System



System provides functions for testing the hardware and backing up and restoring parameter settings.



Asset Management



Asset management provides statistical data of the application collected during general operation.

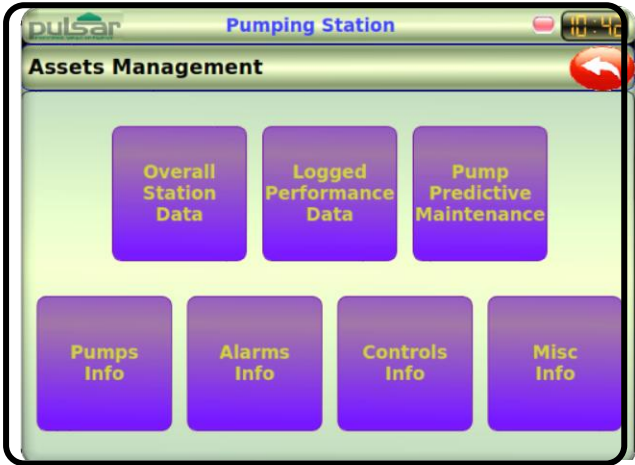

User accounts

The Ultimate Controller uses a user account system where custom usernames and passcodes can be created. Using accounts provides a method of restricting access to certain users, and the username will be logged in the event log each time program mode is accessed. User accounts can only be created or deleted when in program mode as the administrator.

To create a user account from main menu (accessed with passcode 1997)

STEP	ICON	FUNCTION
1		Advanced Config.
2		User accounts

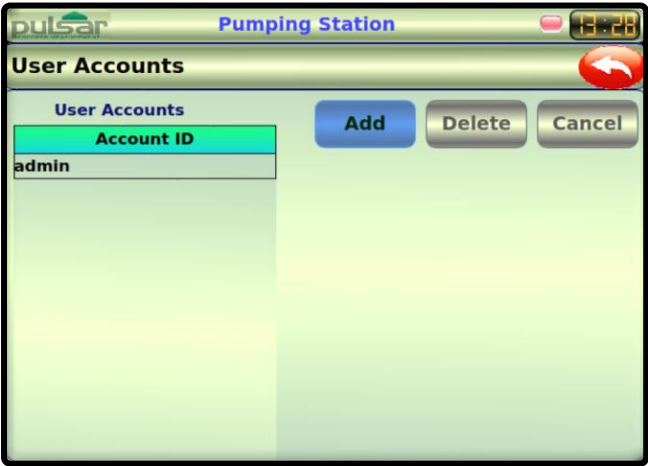

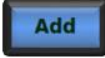
Press  and complete the new account registration boxes.

User ID

Passcode

Repeat Passcode

then press 

It is prudent at this stage for the administrator to change the admin passcode to keep the administrator rights secure.

To change the passcode, simply touch the **admin** entry in the Account ID table, and then amend the Passcode boxes to the required passcode and then press

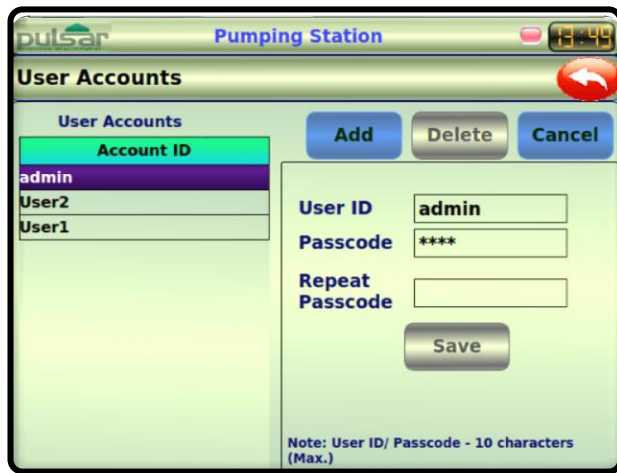
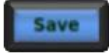



3.3 Parameter Defaults

Factory Defaults

Important Information

When first installing the Ultimate, or subsequently moving or using the unit on a new application, before proceeding to program the unit for its intended application it is recommended that you ensure that all parameters are at their default values by completing a **Factory Defaults**, as described below.

To carry out a Factory Default from main menu (accessed with passcode 1997).

STEP	ICON	FUNCTION
1		Advanced Config.
2		Soft Default

A soft default will delete and return, all user application settings, to their factory default settings, it is recommended that a 'Backup Profile' be taken before proceeding in case it is needed to 'restore' the controller to its original settings.

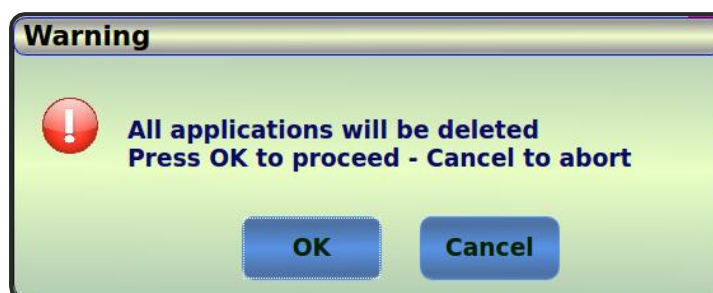

When you first switch the Ultimate on, it will be reading the **distance** from the face of the transducer to the surface. It will be indicating in **metres**, as shown on the display. All relays are set OFF.

The **date** and **time** in the Ultimate were set at the factory, but may need checking, and amending if, for example the application is in a time zone other than GMT, to change see details below.

 **TIP: Look for this icon throughout your Pulsar Measurement manual to find helpful information and answers to frequently asked questions.**

Once you are satisfied with the installation, and the Ultimate is reading what you would expect in terms of distance from the face of the transducer to the material level, then you can proceed with programming, for the intended application. It is sensible to program all the required parameters at the same time. The system will be then set-up.

Note that the span is automatically calculated from the empty level, so the empty level should be entered first.

CHAPTER 4 SET UP MENU

This chapter outlines all parameters available in the Ultimate, as they appear in the Set Up menu.

4.1 Main Menu

Enter Program mode and enter the setup  menu and the Main Menu will be displayed, this screen contains the various sub menus which are used to set up the Ultimate controller for the desired application and configuring the various I/O to the required control functions. Any sub menus that are 'greyed' can either only be accessed by an administrator or the function is not available.



4.2 Application Setup

On the Main Menu screen select 

The application menu handles selection, spanning and scaling of dB transducers and mA input devices, and the creation of measurement points. The application name and global system measurement unit for length are also entered here.

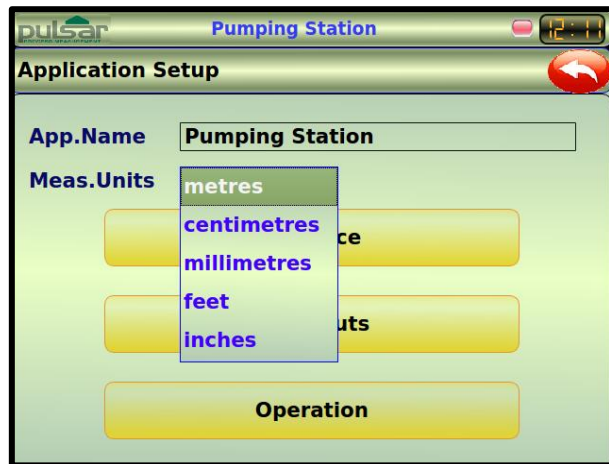
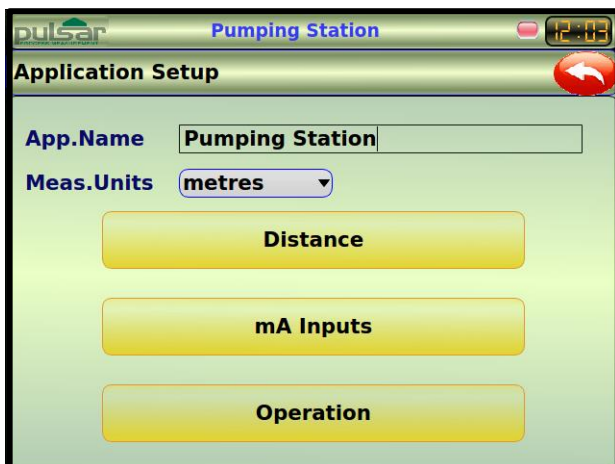

From this screen you can change the App. Name by selecting the text box and entering the required description. Measurement units can also be changed to any of those listed in the drop-down menu, as shown above.

Distance

From the Application Setup Menu select Distance

Ultrasonic Sensor

The distance menu selects the dB transducer type and sets the empty distance, span and blanking distances for the application. The tree list on the left side of the screen can be used to select between transducer 1 and transducer 2 input on the hardware. If any additional Interface Board (IFB) have been registered on the PBUS, the list will include any extra dB transducer inputs available.

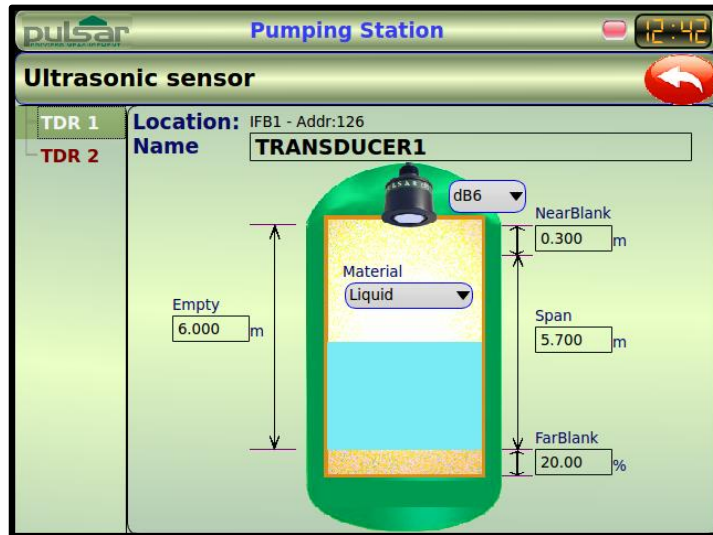

Location

Displays which Interface Board the selected transducer is located upon and its address on the PBUS.

Name

This defaults as transducer 1 (for TDR1) or transducer 2 (for TDR2) but can be renamed to something more application specific if required.

Transducer

The dB6 drop down box is used to select the transducer being used the options are follows.

OPTION	DESCRIPTION
None	No Transducer.
dB3	Transducer is a dB3. Range 0.125 to 3.00 metres
dB6 (Default)	Transducer is a dB6. Range 0.3 to 6.00 metres
dB10	Transducer is a dB10. Range 0.3 to 10.00 metres
dB15	Transducer is a dB15. Range 0.5 to 15.00 metres
dB25	Transducer is a dB25. Range 0.6 to 25.00 metres
dB40	Transducer is a dB40. Range 1.2 to 40.00 metres
dB56	Transducer is a dB56. Range 0.2 to 6.00 metres
dB Mach3	Transducer is a dB Mach3 Range 0.0 to 2.425 metres.
dB R16	Transducer is a mmWave Radar Range 0.077 to 16.00 metres
dB R8	Transducer is a mmWave. Range 0.077 to 8.00 metres

Material

The  drop box allows you to select the type of material being measured by the transducer, after selecting Ultimate will automatically select the best echo algorithm to suit the selection.

OPTION	DESCRIPTION
Liquid (Default)	No Transducer.
Solids	Solid material that is heaped or at an angle.
Closed Tank	Used where material is contained in a closed tank.

Empty

Sets the **maximum distance** from the **face** of the transducer to the **empty point**, (zero level) in **Measurement Units**. Note this value affects span as well, (see important information below), so should be set before span.

Important Information
 When using the **dB Mach 3** the **empty distance** is measured from the end of the **horn** to the **empty point** in **Measurement Units**.

Important Information
 When changing the Empty Distance, you can also recalculate the values for the Span so that it equals the **empty distance minus Near Blanking**. You will be asked the question "Recalculate Span?" if you choose **OK**, then the span will be recalculated.

Near Blank

Near Blanking distance sets, the distance from the face of the transducer that is not measurable. The value defaults to the minimum allowable according to transducer selection. This parameter can be used to make the Ultimate "Ignore" echoes from objects near the transducer above the measurement range.

OPTION	DESCRIPTION
dB3	Default Blanking Distance = 0.125m
dB6 (Default)	Default Blanking Distance = 0.3m
dB10	Default Blanking Distance = 0.3m
dB15	Default Blanking Distance = 0.5m
dB25	Default Blanking Distance = 0.6m
dB40	Default Blanking Distance = 1.2m
dBS6	Default Blanking Distance = 0.2m
dB Mach3	Default Blanking Distance = 0.0m
dBR16	*Default Blanking Distance = 0.077m
dBR8	*Default Blanking Distance = 0.077m

*The signal emanates from the curved face of the Radar, but for the purposes of measurement it is taken from the drip shield.

Span

This Represents the maximum measurable level in the application. This defaults to the Empty - Near blank. This is also the default span used if a mA output is allocated to a measurement point using the level of the transducer.

FarBlank

Far Blanking distance sets the range beyond the empty distance (as a percentage of the empty distance) that the Ultimate will be able to measure. Default 20%

mA Inputs

From the Application Setup Menu select mA Inputs

mA Sensor

This menu defines the type and range of sensor being used at the mA inputs. There is also a facility for a 5-point linearization between the mA input value and the process variable it represents.

The tree list selects which input is currently being configured. An identical screen is used to configure input 2. The graph shows the relationship between the mA input value and the process variable seen by Ultimate.

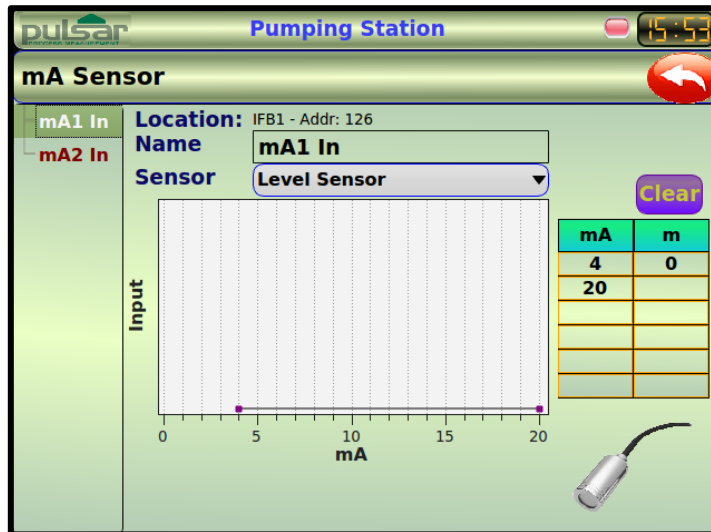

Location

Displays which Interface Board the selected mA input device is located upon and its address on the PBUS.

Name

This defaults as **mA1 In** or **mA2 In** but can be renamed to something more application specific if required.

Sensor

The Level Sensor drop down box is used to select the type of variable the mA input sensor represents, the options are follows.

OPTION	DESCRIPTION
Level (Default)	4 to 20mA input representative of Level.
Flow	4 to 20mA input representative of Flow.
Temperature	4 to 20mA input representative of Temperature.
Velocity	4 to 20mA input representative of Velocity.
Pressure	4 to 20mA input representative of Pressure.

Input Range

mA	m
4	0
12	3
20	5

This table can be edited to set the relationship between the mA input value and the process variable seen by Ultimate. If a linear relationship is required, just the two points are used. Touch the box to be edited and enter the required value.

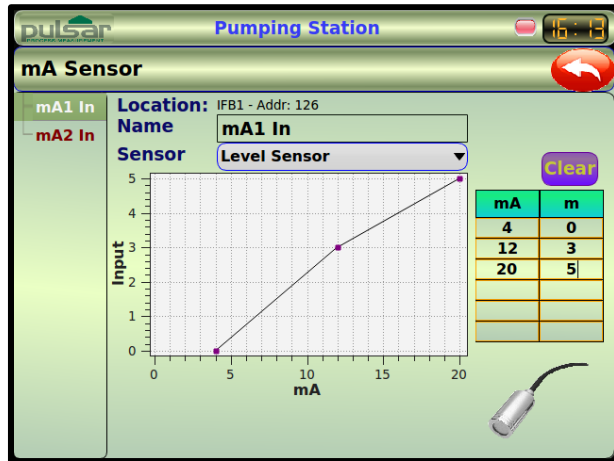

Resets all linearization points for the mA input device.

Operation

From the Application Setup Menu select 

Point Setup

The operation menu takes measurement values from the dB transducers and mA input sensors and assigns them to a point of measurement. By default, there is one point of measurement pre-allocated as the level measurement from transducer 1. This measurement point is also used as the main measurement variable for the display and bar graph in run mode.

Measurement points will be listed by their given names in the tree list on the left-hand side of the screen. Swap between measurement points by touching a name on the tree list. New points can be added, or existing ones deleted. Compound measurement points (Average, Differential, and Summation of two sensor inputs) and validated measurements of multiple sensor inputs can also be created.

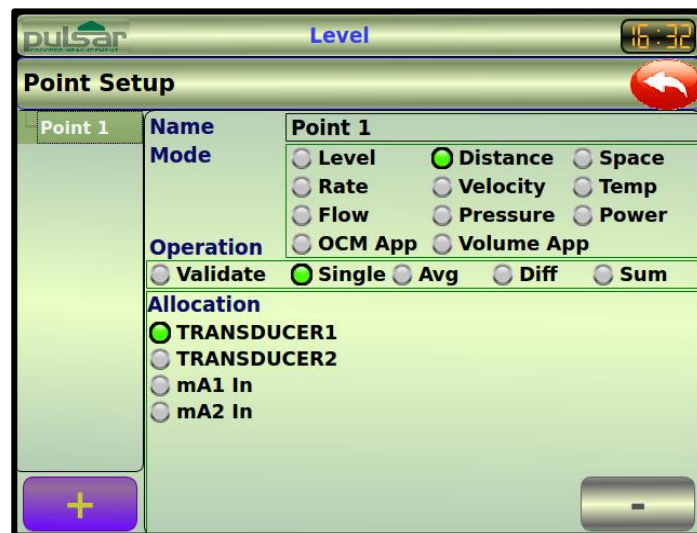

Name

Name of measurement point. This can be edited to suit the application. (e.g., Sump level, Pit level, Chemical Storage, Main Flow etc.)

Mode



Selects the type of measurement that the point will represent. The options will be dynamically modified depending on input device chosen in the **Allocation** section.

Operation

Defines whether the measurement point is single or compound (Validated, Average, Sum, Differential). This information can be displayed in run mode.

Allocation

Lists the available input sensors by their given names that can provide the chosen **Mode**. If extra sensors have been registered on the PBUS port, these will also appear in the allocation list. When a compound measurement point is being created, the Allocation selection method will turn to checkbox (to select multiple sensors).

-  **Adds** a new measurement point to be configured
-  **Deletes** currently selected measurement point.

Example Setup:

Level Measurement

In this example, the transducer connected to TDR1 input has been named Well Xducer. In the operation menu, the measurement has been named Well Level and has been allocated to use the **Level** of **Well Xducer**.

Distance menu

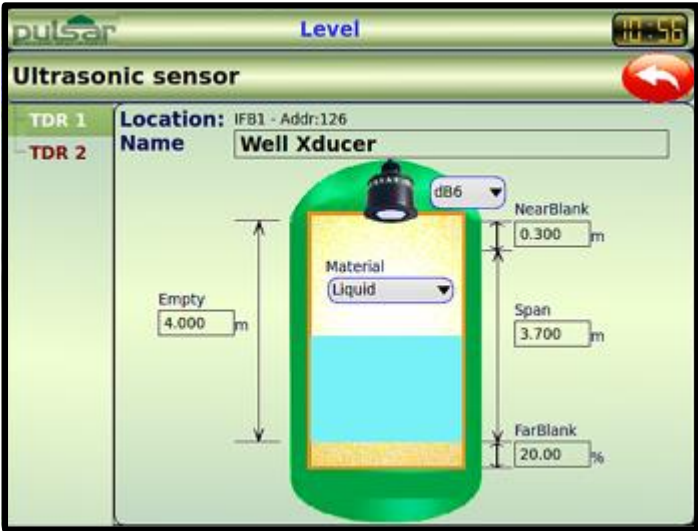

Operation Menu

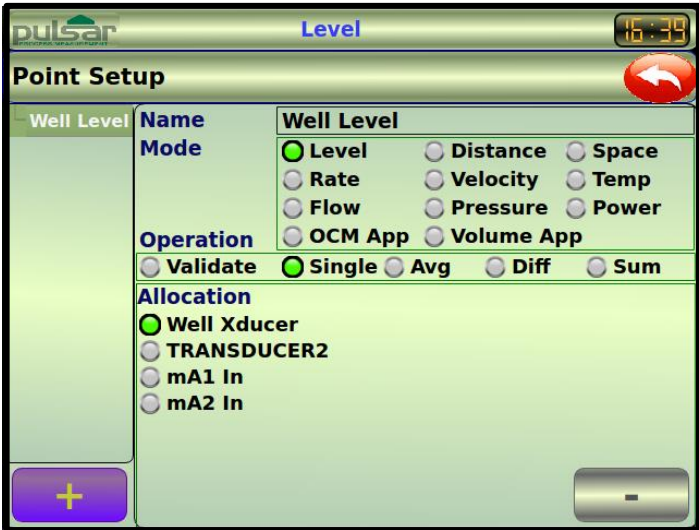

Validation

For critical measurements, multiple sensors can be used to measure the same process to ensure a reliable measurement. Ideally, sensors utilising different technologies and measurement principles should be used to overcome unfavourable process conditions that might affect a single measurement technology.

When a validation measurement point has been selected, there are several methods which define the rules of the measurement validation. For a sensor measurement to be valid, its measured value must be below the **High Limit** and above the **Low limit**.

Method

OPTION	DESCRIPTION
Mean: Validate and average all values (Default)	Uses the average value of all valid sensor inputs
Mode: Validate and average modal values	Uses the average of valid sensor inputs that have the most sensor values within tolerance.
Median: Validate and select Median value	Uses the "middle" value of all valid sensor inputs. If an even number of inputs are valid, the average of the middle two is used.
Custom: Validate and Average Nearest two	Uses the average of the two sensor inputs that are closest together in value.

Tolerance

This sets the tolerance band applied to each sensor input to define the modular values. If the sensor value with the tolerance applied of two or more inputs overlaps, the average of the overlapping inputs is used for the measurement value.

4.3 Relays

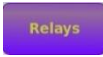
On the Main Menu screen select 

This Relays Menu is used to configure any new relays and to view, edit or delete existing configured relays. To set up or make any changes to existing relays you must first highlight the relay required. Once the required relay is highlighted the 'Clear' and 'Configure' buttons will become available and can be selected for use. To configure a new relay or edit or view the configuration of an existing relay press the 'Configure' button, to delete the settings of an existing relay press the 'Clear' button and follow the on-screen instructions.

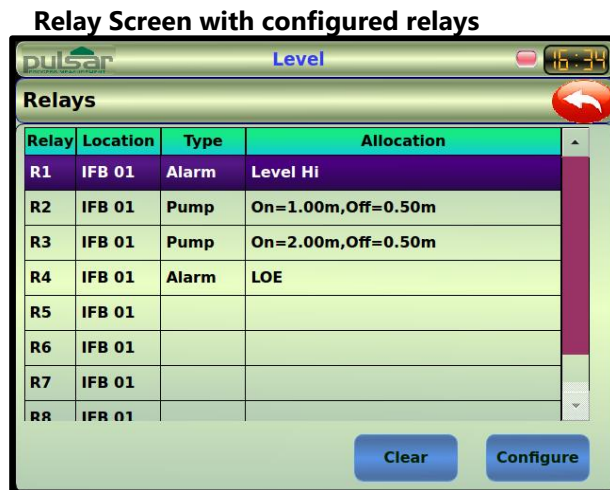
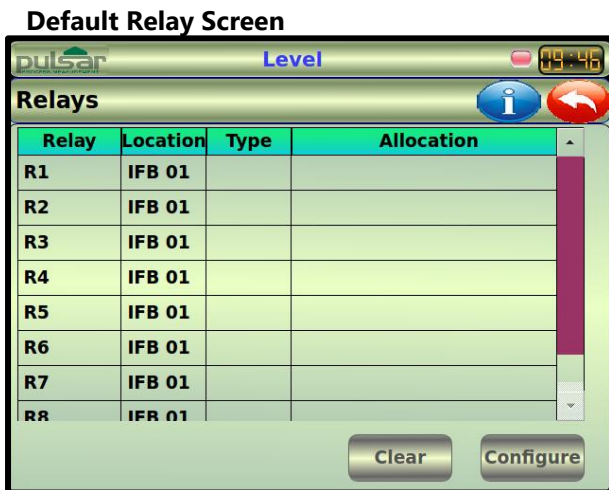

Once you have selected the relay you wish to use and have pressed 'Configure' you will see the screen as detailed on the right. The screen will confirm the Relay number and the Interface Board (IFB) on which it is located, in this case R1 on IFB1*.

*IFB1 is the *Ultimate's* internal set of digital input/outputs, analogue input/outputs and dB transducer inputs.

Type

To proceed with the setup of the relay you must first choose the relay 'Type' from the drop-down box.

All relays can be configured to any of the 'Type' detailed in the following table:

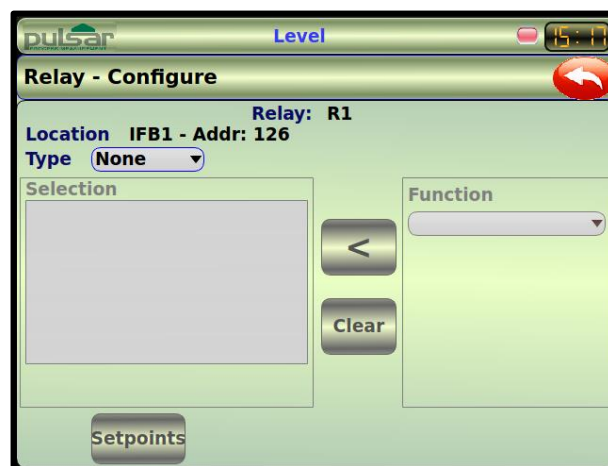

RELAY TYPE	DESCRIPTION
None	Relay is not in use
Pump	Relay is configured to control a Pump, relay will energise to switch the pump On and de-energise to switch the pump OFF.
Alarm	Relay configured to activate an Alarm, relay will de-energise to switch the alarm ON and energise to switch the alarm OFF. This will ensure an alarm condition is initiated if power to the Ultimate fails.
Control	Relay configured as a Control relay which will energise On and de-energise OFF.
Misc.	Relay configured as a Miscellaneous relay which will energise On and de-energise OFF.
Logical	Relay configured to activate when there is a change of state with a Logical Output. The relay will energise ON and de-energise OFF.

Pump

Having selected **'Pump'** as the relay **'Type'** you will be presented with the screen detailed to the right.

Name

If required you can enter a name for the pump in the **'Name'** field.

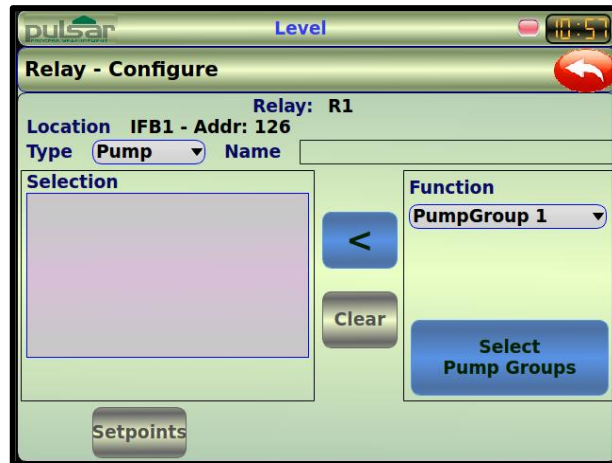

Function

Pump Group

Next you need to determine the **'Pump Group'** you wish to allocate your pump to, you can have up to a total of 5 pump groups and all similar duties within a **'Pump Group'** will work together.

To select the **'Pump Group'** you require, select it from the dropdown box under **'Function'** and then press the blue **'Select Pump Groups'** button which then open a further screen which allow you to set up the **'Pump Duty'** for the selected **'Pump Group'**.

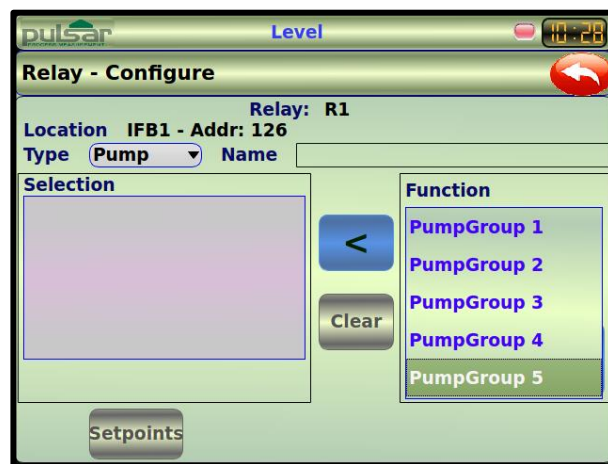

Pump Duty

Once you have selected the chosen **'Pump Group'** you will be presented with another screen, as detailed to the right, which will allow you to select the **'Pump Duty'**. By default, the selected **'Pump Duty'** for all groups is set to **'Fixed Duty Assist' (FDA)** but this can be changed via the **'Pump Duty'** drop down box for the group required for any one of the **'Pump Duty'** detailed in the table that follows.

	Pump Duty	By Time	Eco. Pump
Group 1	FDA	<input type="checkbox"/>	<input type="checkbox"/>
Group 2	FDA	<input type="checkbox"/>	<input type="checkbox"/>
Group 3	FDA	<input type="checkbox"/>	<input type="checkbox"/>
Group 4	FDA	<input type="checkbox"/>	<input type="checkbox"/>
Group 5	FDA	<input type="checkbox"/>	<input type="checkbox"/>

OK

PUMP DUTY	DESCRIPTION
FDA - Fixed Duty Assist (Default)	All pumps are used to assist each other (run at the same time) and each pump has its own setpoints which are configured in the setpoints menu option.
FDB - Fixed Duty Backup	If a pump fails to meet the demand (due to malfunction, intake blockage etc.), then it is stopped, and another pump shall take over. Each pump has its own setpoints which is configured in the setpoints menu option.
ADA - Alternate Duty Assist	All pumps are used to assist each other (run at the same time) and each pump has its own setpoints which is configured in the setpoints menu option. But each time all pumps have stopped, then the setpoints are sequentially rotated between the pumps to ensure equal pump use
ADB - Alternate Duty Backup	If a pump fails to meet the demand (due to malfunction, intake blockage etc.), then it is stopped, and another pump shall take over. Each pump has its own setpoints, which is configured in the setpoints menu option. But each time all pumps have stopped, then the setpoints are sequentially rotated between the pumps to ensure equal pump use
SRDA - Service Ratio Duty Assist	All pumps are used to assist each other (run at the same time) and each pump has its own setpoints and service ratio setting. The third setpoint (also configured in the setpoints menu option) is used to set the service ratio. Each time a pump is required to start then the pump with the least running hours (with respect to the service ratio) is started (i.e., the setpoints are re-assigned accordingly). For example, if two pumps A and B have the service ratio set to 2 and 1 respectively, then pump A will operate for twice as many hours as pump B
SRDB - Service Ratio Duty Backup	If a pump fails to meet the demand (due to malfunction, intake blockage etc.), then it is stopped, and another pump shall take over. Each time a pump is required to start, the pump with the least running hours (with respect to the service ratio) is started (i.e. the setpoints are re-assigned accordingly). Each pump has its own setpoints. The third setpoint (also configured in the setpoints menu option) is used to set the service ratio. For example, if two pumps A and B have the service ratio set to 2 and 1 respectively, then pump A will operate for twice as many hours as pump B.
FOFO - First On First Off (alternate duty assist)	The first pump switched on is the first pump to be switched off, etc. regardless of the set points, so the setpoints are dynamically changed to enable this.
TPS - Two Pump Sets	There are four pumps. Two rotate their start-up sequence with each other. If the two pumps cannot keep up, the level rises to the setpoints of the other two pumps, which take over and rotate their sequence with each other.
DBA - Duty Backup Assist	First pump comes on, if it cannot cope, it goes off and next pump comes on (duty backup). This continues until the last pump comes on and if it cannot cope the first pump comes back on to assist the last pump (duty assist) if the level continues to rise all other pumps will come on (assist) in turn until the level decreases to the pump off points. Each pump has its own setpoints which is configured in the setpoints menu option

Once you have selected the desired 'Pump Duty' you have the choice of further modifying the pump cycle so that the pump can either be set to run 'By Time' or for the most energy efficient pump to be selected to run first 'Eco Pump'. Please note that pump relays can only be allocated to one of these additional control routines and not both.

Pump By Time

When the relay is assigned to, 'By Time' the pump will come on (energise) at its normal "ON" level setpoint, and de-energise at its 'OFF' level setpoint or after a predetermined time period, whichever occurs first.

Economy Pumping

When the relay is assigned to, 'Eco. Pump' priority is given to selecting and starting the most energy efficient pump based on the calculated kWh/m³ (Power and flow monitoring is required).

Setpoints

Once the required 'Pump Duty' has been selected press the 'OK' button and you will be returned to the 'Relay-Configure' screen.

The next step is to enter the setpoints for the pump, the number of setpoints will depend on the 'Pump Duty' chosen and any other additional features selected.

To gain access to the 'Setpoints' press the < button at which time the 'Setpoints' button will change from being greyed out to being highlighted blue, selecting the highlighted Setpoints button will take you to the following screen.

Name

This displays the name given to the relay in the Relay Configure screen.

Details

This confirms to which Pump Group and to what Pump Duty the relay has been configured too.

Setpoints

There are four possible Setpoints to enter, depending on the Pump Duty and any other features selected, as detailed in the table below.

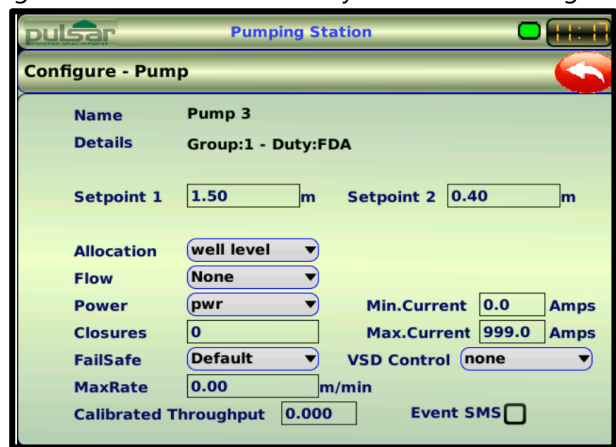

PUMP DUTY	DESCRIPTION
Setpoint 1	Determines the 'ON' point for the pump. When pumping down 'ON' setpoint is set 'higher' than 'OFF' setpoint. When pumping up 'ON' setpoint is set 'lower' than 'OFF' setpoint. Setpoint entered in Display Units (Measurement Units) as referenced to Empty Level.
Setpoint 2	Determines the 'ON' point for the pump. When pumping down 'ON' setpoint is set 'higher' than 'OFF' setpoint. When pumping up 'ON' setpoint is set 'lower' than 'OFF' setpoint. Setpoint entered in Display Units (Measurement Units) as referenced to Empty Level.
Setpoint 3	Only available if SRDA and SRDB pump types have been selected in Pump Duty and will determine the service ratio in values of %. Setpoint entered as a % with reference to Ratio of Usage.
Setpoint 4	Only available when Pump by time selected. Setpoint is entered in seconds.

NAME	DESCRIPTION
Standby	Only available when pump duty SRDA or SRDB is and a pump is used on a standby basis and will only run when it replaces a failed pump. The setpoints of the standby pump will be automatically forced to a high level beyond span to ensure that it only starts when replacing the duty cycle of a failed pump.
Allocation	This allows you to assign the relay to a specific point of measurement as setup in 'Application-Operation'
Flow	This associates a flow measurement point with the pump relay and is required for pump economy calculation.
Flow	This associates a flow measurement point with the pump relay and is required for pump economy calculation.
Power	This associates a power measurement point with a pump relay and is required for pump economy and performance calculations.
Minimum Current	This is only available when a power measurement point has is associated with a pump relay and defines the current threshold (in Amps) for the "Pump under current" register in the dynamic memory.
Maximum Current	This is only available when a power measurement point has is associated with a pump relay and defines the current threshold (in Amps) for the "Pump over current" register in the dynamic memory.
Closures	The Ultimate will record how many times each relay has operated and display the number of times the relay has activated since the relay has been in use in this box. It can be reset with any value
Failsafe	<p>The unit has a general fail-safe selection option in 'Display-Failsafe'. However, this can be overwritten so that each individual relay has its own independent fail-safe mode as follows:</p> <ul style="list-style-type: none"> • Default - relay assumes the default mode as set in Display-Failsafe. • Hold – relay will remain in its current state. • De-energise – relay will de-energise. • Energise – relay will energise
Max Rate	This will allow the relay to be switched at a pre-determined Rate of change of Level, irrespective of the "ON" level (setpoint 1). Once a relay has been switched "ON" by the pre-determined Rate of Change, it will remain energised until the level reaches the "OFF" level (setpoint 2).
Calibrated throughput	Enter the value of the volumetric throughput for the pump which will be used as the starting or comparison value for the calibration factor applied to pump efficiency.
Event SMS	This option when selected will allow a pre-determined message to be sent to a remote telephone number as set in Remote Alarms, detailing the date, time, site ID, level, and relay status at the time the message is sent.
VSD Control	This associates the Pump with a PID control loop setup in the Pump Advanced → VSD Control menu.

Alarm

Function

Having selected 'Alarm' as the relay 'Type' you will be presented with the screen detailed to the left.

Name

If required you can enter a name for the alarm in the 'Name' field.

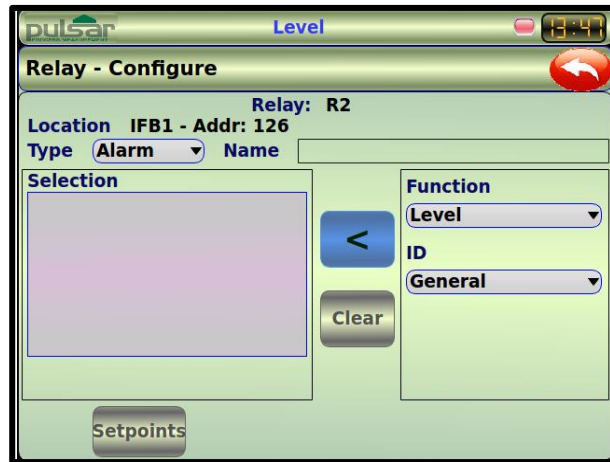

Next you need to determine the 'Function' that the alarm relay will respond to.

To select the 'Function' you require, select it from the dropdown box under 'Function'.

Full details of the 'Functions', and their descriptions, that are available, when the relay is selected as an 'Alarm' relay, are shown in the table below:

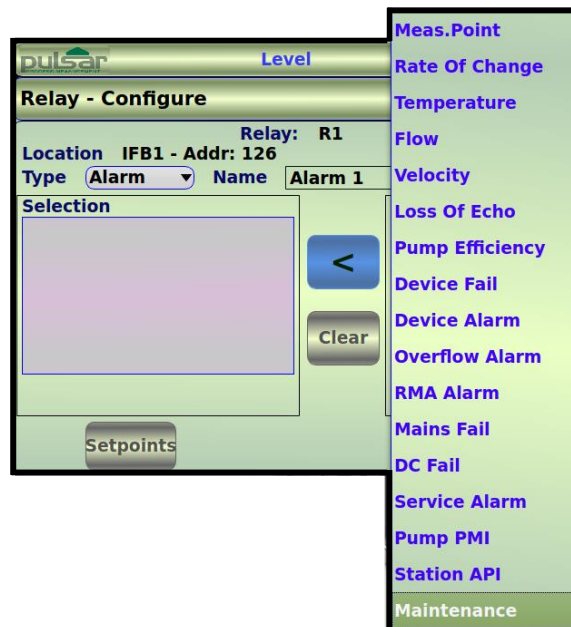

FUNCTION	DESCRIPTION
Measurement Point	Alarm is based on the measurement point, and the ID of the measurement point alarm, two setpoints are required, one for ON and another for OFF. These setpoints are entered in measurement units as referenced to the Empty Level.
Rate of Change	Alarm is based on the rate of change of level in the vessel, and the ID of the rate of change alarm, two setpoints are required, one for ON and another for OFF. These setpoints are entered in measurement units per minute. A negative value should be entered for a Rate Alarm on a de-creasing level, and a positive value for an increasing level.
Temperature	Alarm is based on the temperature, and the ID of the temperature alarm, two setpoints are required, one for ON and another for OFF. Temperature used depends on the temperature source. Setpoints entered in °C
Flow	Alarm is based on flow, when available, and the ID of the alarm. Both setpoints must be set and are entered in the display units
Velocity	Alarm is based on velocity, when available, and the ID of the alarm, setpoints must be set in metres/second

FUNCTION	DESCRIPTION
Loss of Echo	Alarm is raised if the Failsafe timer (refer to section '8.3 - Failsafe' on how to change this value) expires and no setpoints are required
Pump Efficiency	When Pump Efficiency is enabled, Alarm is based on the Efficiency of the pump which is allocated to the Relay I.D. and setpoints1 & 2 must be set and are entered in %
Device Fail	Alarm is raised if a device, connected to the relay assigned in Alarm ID fails, e.g. pump is put out of service. No setpoints are required
Device Alarm	Alarm is raised if a fail signal is detected on the digital input as assigned in Alarm ID. No setpoints are required
Overflow Alarm	This alarm is used in conjunction with the Pump Advanced > Overspill feature. And will energise when there is an overflow condition
RMA Alarm	Used in conjunction Pump Advanced > Block & Burst feature. Alarm is based on the rate of change of level during a pumping cycle, and on the ID of the alarm. 3 points are set, Alarm setpoint in rate measurement units, Min Head in level display units where the alarm will not activate below this level. And Persistence time in seconds.
Mains Fail	Alarm is raised if AC power is lost from the Ultimate controller.
DC Fail	Alarm is raised if DC power is lost from the Ultimate controller.
Service Alarm	This alarm is raised when the Ultimate controller is due for a service, the default value is 5000 hours. (90 hours in version 2.0)
Pump PMI	Alarm is raised based on the pump PMI and indicates that the pump's performance has fallen below the required criteria (see Chapter 7.3 Pump predictive maintenance)
Station API	Alarm is raised based on the station API and indicates that the station performance has fallen below the required criteria (see page 181 - Station API (Assets Performance Index).
Maintenance	Alarm is raised when the maintenance mode Timeout has expired i.e., if the Ultimate has been left in Maintenance mode.

Alarm ID

Level, Rate, Temperature, Flow or Velocity

When the alarm function **Level, Rate of Change, Temperature, Flow or Velocity** is selected an 'ID' can be chosen for the alarm.

To select the 'ID' you require, select it from the dropdown box under 'ID'.

The table below shows the ID options, and their descriptions, which are available and to which the relay will respond to if selected:

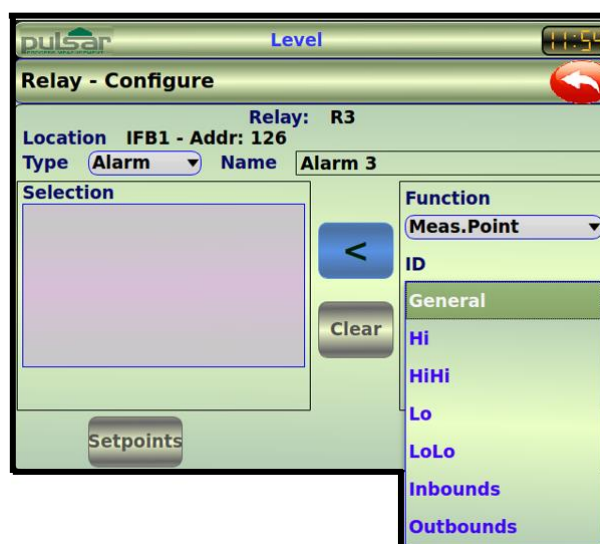

ALARM ID	DESCRIPTION
General = Default	Relay goes "ON" when the value rises to the ON setpoint and goes "OFF" when the value lowers to the OFF setpoint
High	Relay goes "ON" when the value rises to the ON setpoint and goes "OFF" when the value lowers to the OFF setpoint. Setpoints can be set in any order as the unit 'knows' that you are setting a high-level alarm
HiHi	This is the same as High but a different identifier.

ALARM ID	DESCRIPTION
Low	Relay goes "ON" when the value lowers to the ON setpoint and goes "OFF" when the value rises to the OFF setpoint. Setpoints can be set in any order as the unit 'knows' that you are setting a low-level alarm
LoLo	This is the same as Low but a different identifier
Inbounds	Relay goes "ON" if value is inside the zone between the two setpoints. Setpoints can be set in any order as the unit 'knows' that you are setting an inbounds alarm.
Outbounds	Relay goes "ON" if value is outside the zone between the two setpoints. Setpoints can be set in any order as the unit 'knows' that you are setting an out of bounds alarm.

LOE, Overflow, Service and Station API

Alarm ID option is not required for alarms set as **Loss Of Echo, Overflow Alarm, Service Alarm** and **Station API Alarm**.

Efficiency or Pump PMI

When the alarm function **Pump Efficiency** or **Pump PMI** is selected then the 'ID' selection is used to assign the alarm to the appropriate pump. You can choose to set an individual pump or by choosing **Any Pump** the alarm is assigned to all pumps.

To select the 'ID' you require, select it from the dropdown box under 'ID'.

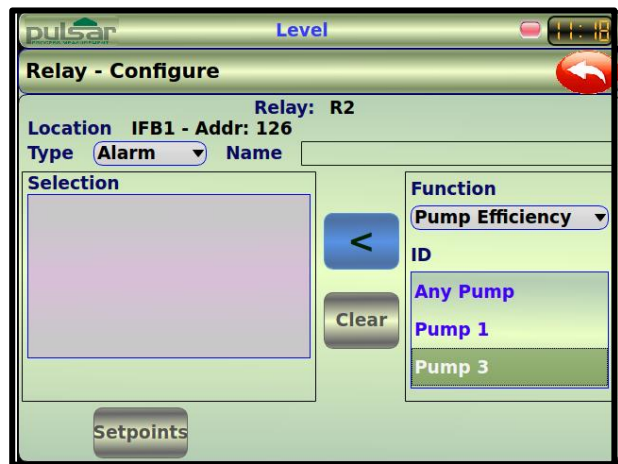

Device Fail

Device Fail alarm relays are used in conjunction with Digital Inputs. An alarm is raised when a device (pump) allocated to the relay assigned in ID fails.

When the alarm function **Device Fail** is selected then the 'ID' selection is used to assign the alarm to the appropriate relay.

Or you may select either '**Any 1 Fail**' which will energise the relay 'ON' if a device failure is detected on any 1 relay, or '**Any 2 Fail**' where the relay energises 'ON' when 2 device failures are detected on any 2 relays.

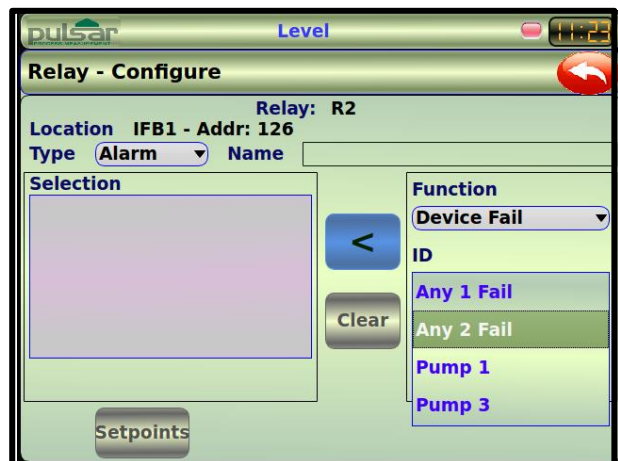

Device Alarm

When the alarm function **Device Alarm** is selected then the 'ID' defines which digital input the alarm should respond to.

The DIN number selected will cause the relay to go on if a fail signal is detected on that digital input.

To select the 'ID' you require, select it from the dropdown box under 'ID'.

To select the 'ID' you require, select it from the dropdown box under 'ID'.

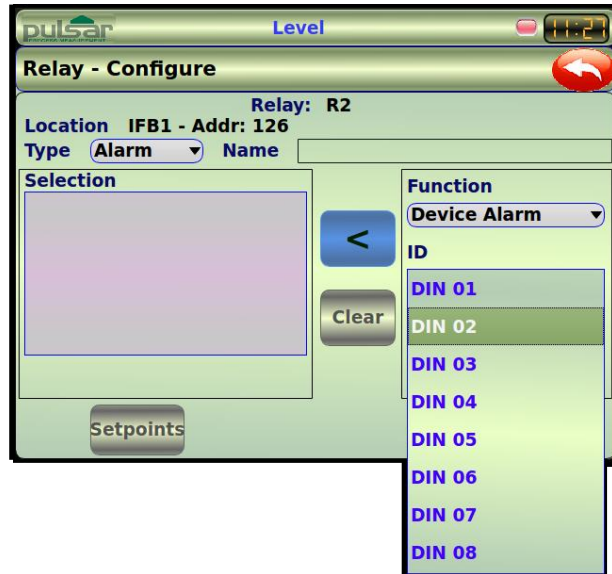

RMA

RMA alarms are used in conjunction with the Block and Burst feature (see page 78 '**Block & Burst**').

When the alarm function **RMA** is selected there are four alarm 'ID's that the relay could respond, details of each, and the number of setpoints required are listed in the following table:

To select the 'ID' you require, select it from the dropdown box under 'ID'.

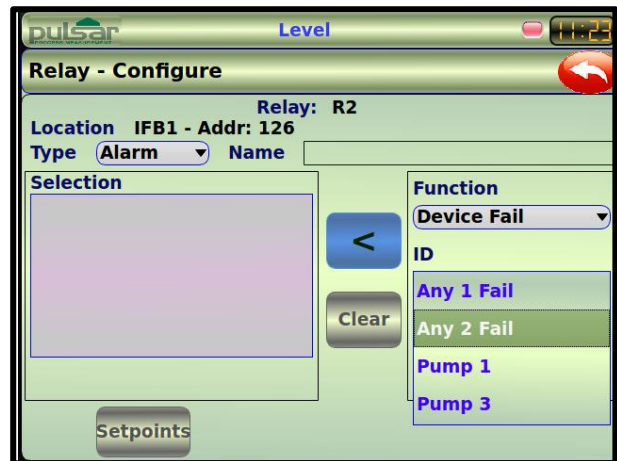

To select the 'ID' you require, select it from the dropdown box under 'ID'.



ALARM ID	DESCRIPTION
Blockage	Relay goes 'ON' when the pumping rate is lower than the Min Rate setpoint for longer than the Persistence Time provided the level is above the Min Head and goes 'OFF' when the pumping rate rises above Min Rate setpoint for longer than the Persistence Time .
Burst	Relay goes 'ON' when the pumping rate is above the Max Rate setpoint for longer than the Persistence Time provided the level is above the Min head and goes 'OFF' when the pumping rate lowers below the Max Rate setpoint for longer than the Persistence Time .
NRV (Non-Return Valve)	This alarm triggers on the detection of flow on idle pumps, and the relay goes 'ON' when a pumping rate above the Max Rate is seen in a FlowPulse that is allocated to either an individual pump relay or all pumps, for longer than the Persistence Time , provided the level is above the Min Head and goes 'OFF' when the pumping rate lowers below the Max Rate setpoint for longer than the Persistence Time .
Storm	Relay goes 'ON' when the pumping rate is above the Max Rate setpoint and the level is above the Storm Level , regardless of the rate, for longer than the Persistence Time provided the level is above the Min head and goes 'OFF' when the pumping rate lowers below the Max Rate setpoint for longer than the Persistence Time .

Setpoints

Once the required '**Alarm Function**' and the appropriate '**ID**' have been selected, the next step is to enter the setpoints for the '**Alarm**' chosen.

To gain access to the '**Setpoints**' press the  button at which time the '**Setpoints**' button will change from being greyed out to being highlighted blue, selecting the highlighted  button will take you to the following screen.

Level, Rate, Temperature, Flow, Velocity or Pump Efficiency

When the '**Alarm Function**' is '**Level**', '**Rate of Change**', '**Temperature**', '**Flow**', '**Velocity**' or '**Pump Efficiency**' two setpoints are required.

Name

This displays the name given to the relay in the Relay Configure screen.

Setpoints

The Setpoints are used to determine the '**ON**' and '**OFF**' points for the '**Alarm**' as shown in the table below.

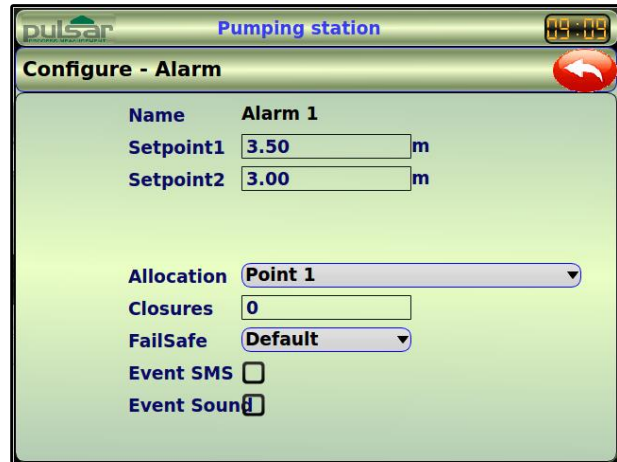

ALARM ID	DESCRIPTION
Setpoint 1	Determines the 'ON' point for the 'Alarm', according to the ' Alarm ID ' selected.
Setpoint 2	Determines the 'OFF' point for the 'Alarm', according to the ' Alarm ID ' selected.

Setpoints are entered in values according to the **function** selected.

- **Level** - entered in Display Units (Measurement Units) as referenced to Empty Level.
- **Rate of Change** - entered in Display Units (Measurement Units) per minute. For an alarm on an increasing level enter setpoints as a positive value, for an alarm on a decreasing level enter setpoints as a negative value.
- **Temperature** - entered in °C.
- **Flow** – entered in flow Units per time period e.g., ltrs/sec, or m³/hour.
- **Velocity** – entered in m/sec.
- **Pump Efficiency** – entered in % value of efficiency.

RMA

When the 'Alarm Function' is 'RMA' setpoints are dependent on the 'Alarm ID' selected and details of all setpoints are shown in the table below.

Name

This displays the name given to the relay in the Relay Configure screen.

Setpoints

The Setpoints are used to determine the 'ON' and 'OFF' points for the 'Alarm' as shown in the table below.

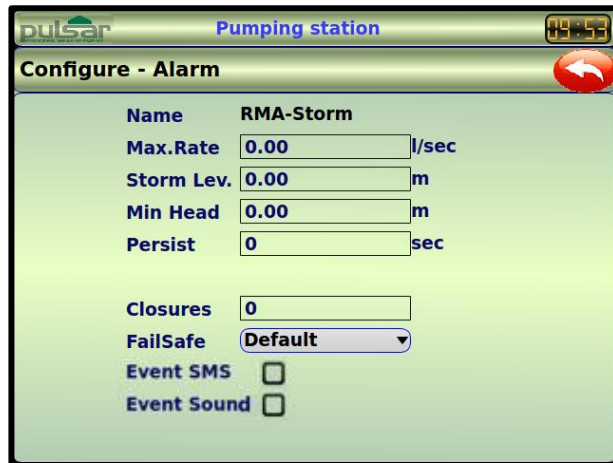

ALARM ID	DESCRIPTION
Max Rate / Min Rate	These determine the RMA alarm ON/OFF points, this is the rate of change during pumping at which a potential condition may occur (depending on Relay Alarm ID). Units are in rate measurement units.
Persist	This is the amount of time the rate must persist above/below the alarm setpoint before the alarm will change state. It is used to prevent relay 'chatter' if the rate is near the alarm setpoint. Units are in seconds.
Minimum Head	An alarm will not be raised below this level but will allow an alarm to turn off. The units are in the measurement units displayed.
Storm Level	Determines the level at which a Storm condition is in effect. Entered in measurement units displayed.

Mains or DC Fail

When the 'Alarm Function' 'Mains Fail' or 'DC Fail' is selected you will be asked to enter a value for Persist this is the amount of time, in seconds, that the failure must 'persist' before the alarm is activated, no further setpoints are required.

Name

This displays the name given to the relay in the Relay Configure screen.

Setpoint

The Setpoint is used to determine the amount of time, in seconds, that the failure must 'persist' before the alarm is activated.

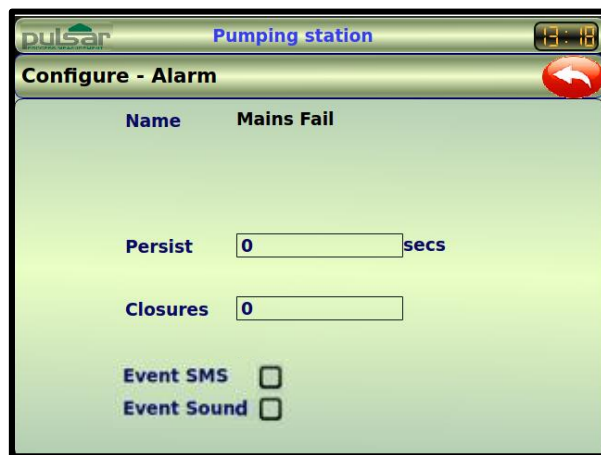

Station API

When the 'Alarm Function' 'Station API' is selected, you will be asked to enter a value for Threshold entered as a % of the 'Station API' at which the alarm is to be activated.

Name

This displays the name given to the relay in the Relay Configure screen.

Setpoint

The Setpoint is used to determine the the **Threshold** at which the alarm is to be activated.

The screenshot shows the 'Configure - Alarm' window in the Pulsar interface. The window title is 'Configure - Alarm' and it has a 'Level' indicator and a clock showing 12:23. The 'Name' field is 'API Alarm'. The 'Threshold' field is set to '0.00' with a '%' symbol to its right. Below this, there is a 'secs' label. The 'Closures' field is set to '0'. At the bottom, there are two checkboxes: 'Event SMS' and 'Event Sound', both of which are currently unchecked.

LOE or Overflow

When the 'Alarm Function' is 'Loss of Echo' or 'Overflow' no setpoints are required but you must **allocate** the alarm to a specific **point of measurement**.

Name

This displays the name given to the relay in the Relay Configure screen.

The screenshot shows the 'Configure - Alarm' window in the Pulsar interface. The window title is 'Configure - Alarm' and it has a 'Level' indicator and a clock showing 12:26. The 'Name' field is 'LOE'. Below this, there is a 'secs' label. The 'Allocation' field is a dropdown menu set to 'Point 1'. The 'Closures' field is set to '0'. At the bottom, there are two checkboxes: 'Event SMS' and 'Event Sound', both of which are currently unchecked.

Device Fail, Device Alarm, Service or Pump PMI

When the 'Alarm Function' is 'Device Fail', 'Device Alarm', 'Service' or 'Pump PMI' no setpoints or allocation are required.

Name

This displays the name given to the relay in the Relay Configure screen.

The screenshot shows the 'Configure - Alarm' window in the Pulsar interface. The window title is 'Configure - Alarm' and it has a 'Level' indicator and a clock showing 12:40. The 'Name' field is 'Alarm 4'. Below this, there is a 'secs' label. The 'Closures' field is set to '0'. The 'FailSafe' field is a dropdown menu set to 'Default'. At the bottom, there are two checkboxes: 'Event SMS' and 'Event Sound', both of which are currently unchecked.

Other Parameters

ALARM ID	DESCRIPTION
Closures	The Ultimate will record how many times each relay has operated and display the number of times the relay has activated since the relay has been in use in this box. It can be reset with any value
Allocation	This allows you to assign the relay to a specific point of measurement as setup in 'Application-Operation'
Failsafe	The unit has a general fail-safe selection option in ' Display-Failsafe '. However, this can be overwritten so that each individual relay has its own independent fail-safe mode as follows: <ul style="list-style-type: none"> • Default - relay assumes the default mode as set in Display-Failsafe • Hold – relay will remain in its current state. • De-energise – relay will de-energise. Energise – relay will energise
Event SMS	This option when selected will allow a pre-determined message to be sent to a remote telephone number as set in Remote Alarms , detailing the date, time, site ID, level and relay status at the time the message is sent.

Control

Function

Having selected '**Control**' as the relay '**Type**' you will be presented with the screen detailed to the right.

Name

If required you can enter a name for the control function in the '**Name**' field.

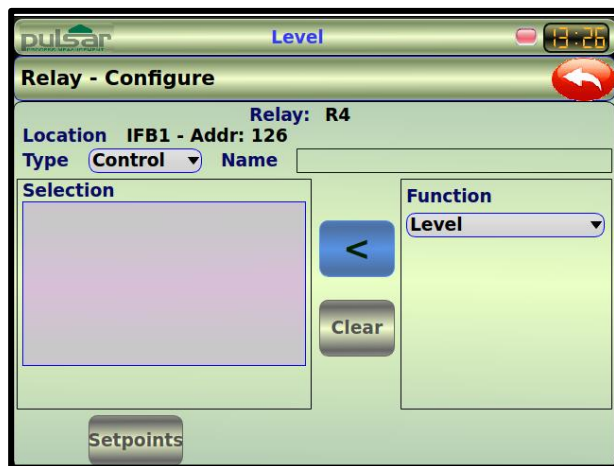

Next you need to determine the **'Function'** that the control relay will respond to.

To select the **'Function'** you require, select it from the dropdown box under **'Function'**.

Full details of the **'Functions'**, and their descriptions, that are available, when the relay is selected as a **'Function'** relay, are shown in the table below:

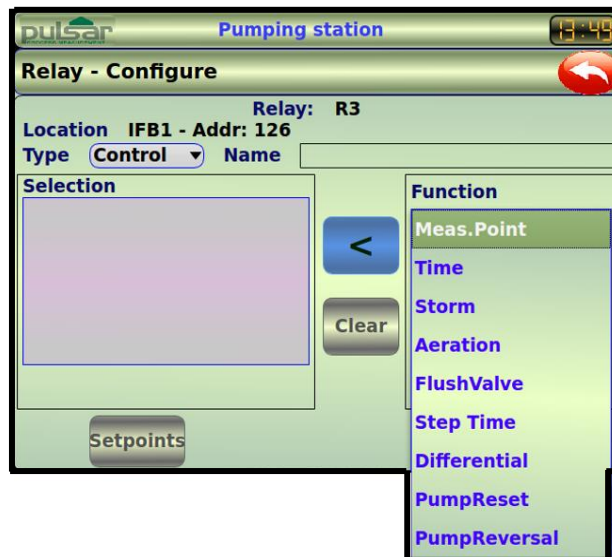

FUNCTION	DESCRIPTION
Measurement Point	Relay will function with respect to the measurement point and will come ON at the On Level and go OFF at the Off Level . Setpoints are entered in measurement units displayed.
Time	Relay will function in respect to time, the relay will come ON after the entered Cycle Time and go OFF after the chosen On Time . Setpoints are entered in minutes.
Storm	Relay will come ON when a storm condition is in effect and the level reaches the Storm Level and go OFF when the level falls to the Reset Level . Used in conjunction with Storm Detect see Pump Advanced features. Setpoints entered in measurement units as referenced to the Empty Level.
Aeration	Relay will function in respect to the time since All Pumps have gone OFF . Relay will come ON after the entered Cycle Time , which starts from the time that All Pumps have switched Off and go OFF after the chosen Cycle Time . This can be used to activate a device based on elapsed time since all pumps have switched off, such as a mixer/stirrer or the introduction of fresh air to reduce gas concentration. Setpoints are entered in minutes.
Flush Valve	Relay will come ON when Flush condition is in effect and goes off when Flush condition is cleared. A relay being used for Flush Valve/Pump must be assigned to one of the main pumps in use. Flush relay ID is used to enter the relay number , to which the assigned pump is connected. The relay will operate after the number of Start Cycles have elapsed, which is the number of main pump cycles that should occur before the Flush Valve/Pump operates. The relay will continue to operate for a set number of Flush cycles meaning that the relay will be operated for a number of main pump starts after which the Flush Valve activity will cease until the Flush Interval comes around again. The duration of each Flush Cycle is set by the Flush Duration which is entered in seconds.

FUNCTION	DESCRIPTION
Step Time	<p>Step Time Control allows relays to be used to control a device, such as a motorised valve or gate, to maintain the level within two predetermined points. Relays will come ON when Step Time condition is in effect and go OFF when the level is maintained at the required level.</p> <p>One relay will be required to control an increase in level, ('open' the device) and a second relay is required to control a decrease in level, ('close' the device). Step Time ID is used to assign the relay to control either the open or close condition.</p> <p>The relay will operate when the Control Level is reached, and the Start Delay time has elapsed and will remain ON for the desired Duration. N.B. Control Level for open relay, increase the level, must be lower than the Control Level for the close relay, decrease the level.</p>
Differential	<p>This allows the relay to be used to activate a device as a result of a differential level, between two points e.g., operate a rake on a screen. Relay will come ON when a differential condition is in effect and go OFF when the differential conditions cease.</p> <p>Setpoints entered in measurement units to the differential required.</p>
Pump Reset	<p>This allows the relay to be used to reset a failed pump and is used in association with Auto Reset function, see Pump Advanced features.</p> <p>The relay will come ON for the period of the Reset Pulse after expiry of the Reset Interval, provided the level is above the Prime Level, as set in Pump Advanced, Auto Reset. Pump Reset ID is used to enter the pump to which the reset is to be applied.</p>
Pump Reversal	<p>This is used with the Pump Reversing feature and allows the relay to be used when the Action in the Pump Reversing menu includes Reverse.</p> <p>The Relay needs to be wired to contactors that allow the pump motor to run in reverse direction when energised. One reverse relay is required per pump.</p>

ID

Flush Valve or Pump Reset

When the control function **Flush Valve** or **Pump Reset** is selected an '**ID**' must be assigned to the relay

To select the '**ID**' you require, select it from the dropdown box under '**ID**'.

When the alarm function **Flush Valve** or **Reset** is selected then the '**ID**' defines which pump the '**Function**' should be applied to.

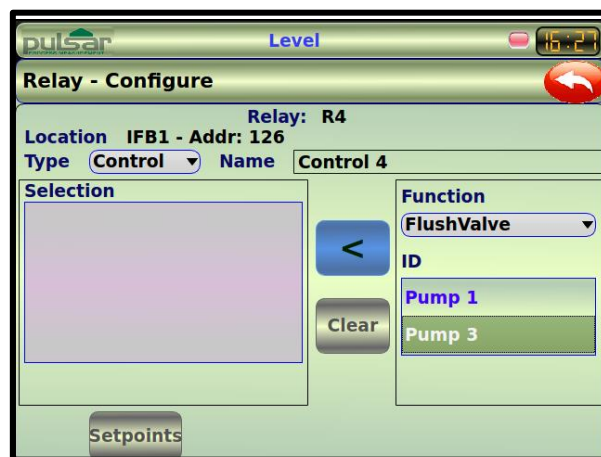

Step Time

When the control function **Step Time** is selected an **'ID'** must be assigned to the relay

To select the **'ID'** you require, select it from the dropdown box under **'ID'**.

When the alarm function **Step Time** is selected then the **'ID'** is used to determine if the relay is to be used to control an **Open PSC** condition or a **Close PSC** condition.



Setpoints

Once the required **'Control Function'** and the appropriate **'ID'** have been selected, the next step is to enter the setpoints for the **'Control'** chosen.

To gain access to the **'Setpoints'** press the **<** button at which time the **'Setpoints'** button will change from being greyed out to being highlighted blue, selecting the highlighted **Setpoints** button will take you to the following screen.

Level or Storm

When the **'Control Function'** is **'Measurement point'** or **'Storm'** two setpoints are required.

Name

This displays the name given to the relay in the Relay Configure screen.

Setpoints

The Setpoints are used to determine the **'ON'** and **'OFF'** points for the **'Control Function'** as shown in the table below.

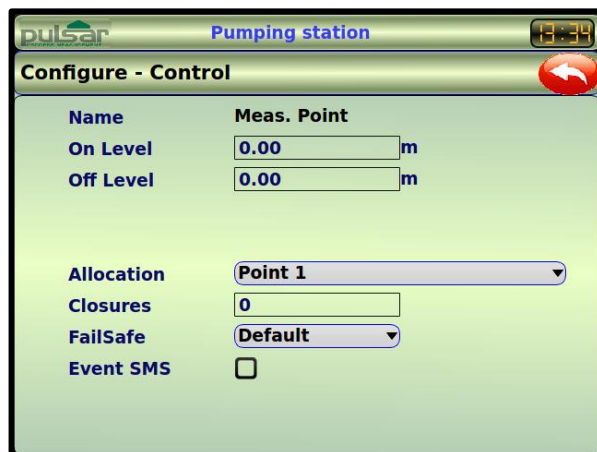

SETPOINTS	DESCRIPTION
On or Storm Level	Determines the 'ON' point for the relay, according to the 'Control Function' selected. Setpoint is entered in Display Units (Measurement Units) as referenced to Empty Level.
Off or Reset Level	Determines the 'OFF' point for the relay, according to the 'Control Function' selected. Setpoint is entered in Display Units (Measurement Units) as referenced to Empty Level.

Time or Aeration

When the 'Control Function' is 'Time' or 'Aeration' two setpoints are required.

Name

This displays the name given to the relay in the Relay Configure screen.

Setpoints

The Setpoints are used to determine 'When' and for what 'Duration' the 'Control' relay will operate for, as shown in the table below.

The screenshot shows the 'Configure - Control' interface for a 'Pulsar Pumping station'. The 'Name' field is set to 'Time'. Below it, 'Cycle Time' and 'On Time' are both set to '0.00 min'. There is a 'Closures' field set to '0' and an 'Event SMS' checkbox which is unchecked.

SETPOINTS	DESCRIPTION
Cycle Time	Determines the Cycle Time that must elapse before the relay will switch 'ON'. Setpoint is entered in minutes.
On Time	Determines the period of time, On Time that the relay will remain active for before being switched 'OFF'. Setpoint is entered in minutes.

Flush Valve

When the 'Control Function' is 'Flush Valve' three setpoints are required.

Name

This displays the name given to the relay in the Relay Configure screen.

Setpoints

The Setpoints which are used to determine 'When', how 'Often' and for what 'Duration' the relay will operate for are detailed in the table below.

The screenshot shows the 'Configure - Control' interface for a 'Pulsar Pumping station'. The 'Name' field is set to 'FlushValve'. Below it, 'Start Cycles', 'Flush Cycles', and 'Flush Time' are all set to '0' with units of 'cycles', 'cycles', and 'secs' respectively. There is a 'Closures' field set to '0', a 'FailSafe' dropdown menu set to 'Default', and an 'Event SMS' checkbox which is unchecked.

SETPOINTS	DESCRIPTION
Start Cycles	Determines the number of pump cycles that must be completed before the Flush Valve will be switched 'ON'. Setpoint is entered as a number of cycles.
Flush Cycles	Determines the number of pump cycles over which the Flush Valve continues to operate. Setpoint is as a number of cycles.
Flush Time	Determines the duration of the Flush Cycle . After which it will switch 'OFF'. Setpoint is entered in seconds.

Step Time

When the 'Control Function' is 'Step Time', it allows relays to be used to control a device. Such as a motorized valve or gate, in order to maintain the level, three setpoints are required.

Name

This displays the name given to the relay in the Relay Configure screen.

Setpoints

The Setpoints which are used to determine the 'Level' at which the relay will become active, the 'Delay' time before the relay will activate and the 'Duration' that the relay will remain active for are detailed in the table below.

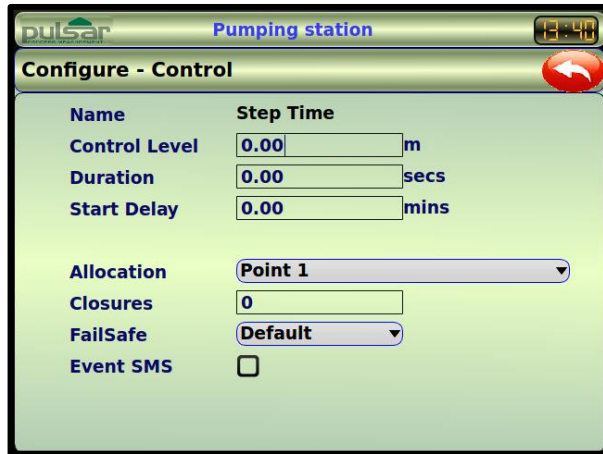

SETPOINTS	DESCRIPTION
Control Level	Determines the level , at which the relay is to be activated, N.B. level setpoint for open relay, (increase the level), must be lower than the setpoint for the close relay, (decrease the level). Setpoint is entered in Display Units (Measurement Units) as referenced to Empty Level.
Duration	Determines the period of time that the relay will remain active after which it will switch 'OFF'. Setpoint is entered in seconds.
Start Delay	Determines the time after which the level has been reached before the relay will switch 'ON'. Setpoint is entered in minutes

Differential

When the 'Control Function' is 'Differential' two setpoints are required.

Name

This displays the name given to the relay in the Relay Configure screen.

Setpoints

The Setpoints are used to determine the 'ON' and 'OFF' points for the relay as detailed in the table below.

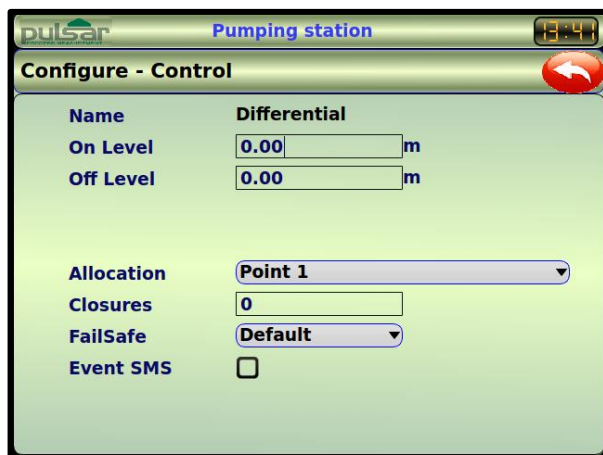

Pump Reset

When the '**Control Function**' is selected for '**Pump Reset**', there are no setpoints required.

Name

This displays the name given to the relay in the Relay Configure screen.

The screenshot shows a mobile application interface for a 'Pulsar Pumping station'. The top bar displays the 'pulsar' logo and 'Pumping station' with a digital clock showing 13:48. Below the bar is a title 'Configure - Control' with a red back arrow icon. The main content area has a light green background and contains the following fields:

- Name:** Pump Reset
- Closures:** A text input field containing the number '0'.
- Event SMS:** An unchecked checkbox.

Pump Reversal

When the '**Control Function**' is selected for '**Pump Reversal**', there are no setpoints required.

Name

This displays the name given to the relay in the Relay Configure screen.

The screenshot shows a mobile application interface for a 'Pulsar Pumping station'. The top bar displays the 'pulsar' logo and 'Pumping station' with a digital clock showing 13:48. Below the bar is a title 'Configure - Control' with a red back arrow icon. The main content area has a light green background and contains the following fields:

- Name:** Pump Reversal
- Closures:** A text input field containing the number '0'.
- Event SMS:** An unchecked checkbox.

Other Parameters

NAME	DESCRIPTION
Closures	The Ultimate will record how many times each relay has operated and display the number of times the relay has activated since the relay has been in use in this box. It can be reset with any value
Allocation	This allows you to assign the relay to a specific point of measurement as setup in 'Application-Operation'
Failsafe	The unit has a general fail-safe selection option in ' Display-Failsafe '. However, this can be overwritten so that each individual relay has its own independent fail-safe mode as follows: <ul style="list-style-type: none"> • Default - relay assumes the default mode as set in Display-Failsafe. • Hold – relay will remain in its current state. • De-energise – relay will de-energise. Energise – relay will energise
Event SMS	This option when selected will allow a pre-determined message to be sent to a remote telephone number as set in Remote Alarms, detailing the date, time, site ID, level, and relay status at the time the message is sent.

Miscellaneous

Function

Having selected **'Miscellaneous'** as the relay **'Type'** you will be presented with the screen detailed to the right.

Name

If required you can enter a name for the miscellaneous function in the **'Name'** field.

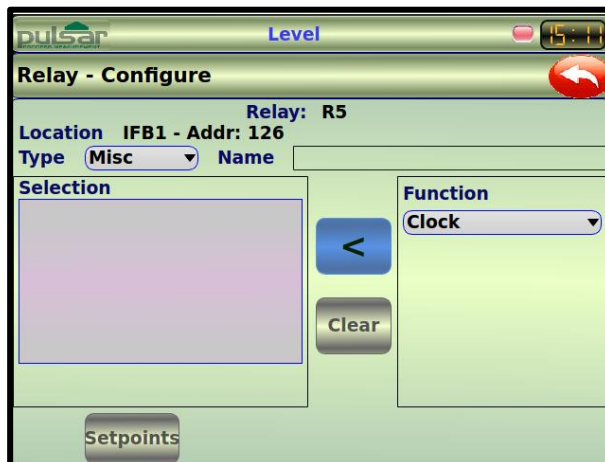

Next you need to determine the **'Function'** that the control relay will respond to.

To select the **'Function'** you require, select it from the dropdown box under **'Function'**.

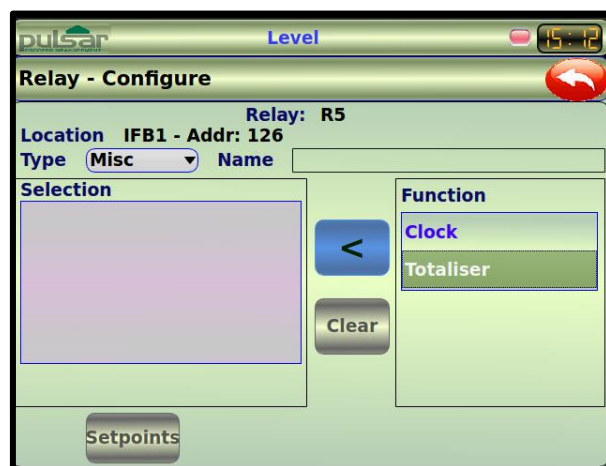

There are two **'Functions'**, available and both are described in the table below:



FUNCTION	DESCRIPTION
Clock	Relay will turn 'ON' at a specified time each day and it will turn 'OFF' after the specified 'Duration' period.
Totaliser	Relay will energise 'ON' momentarily each time the specified units of flow or volume have passed.

Setpoints

Once the required **'Miscellaneous Function'** has been selected, the next step is to enter the setpoints for the function chosen.

Press the  button to allow access the setpoints screen. Pressing the  button will take you to the following screen.

Clock

When the 'Miscellaneous Function' is 'Clock' two setpoints are required.

Name

This displays the name given to the relay in the Relay Configure screen.

Setpoints

The Setpoints are used to determine the 'ON' and 'OFF' points for the relay as shown in the table below.

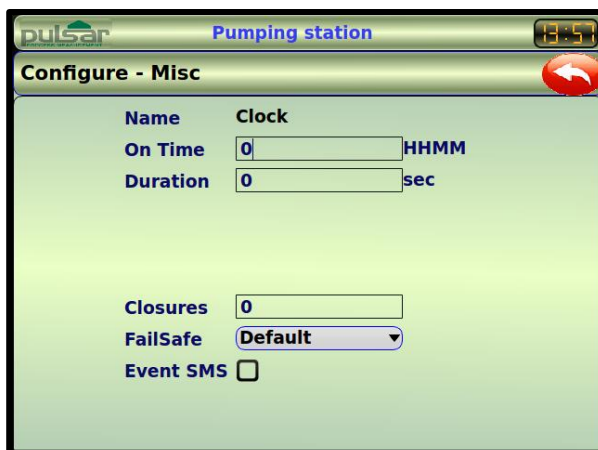

SETPOINTS	DESCRIPTION
On Time	Determines the time of day at which the relay will operate. Setpoint is entered in Hours and Minutes (HHMM).
Duration	Determines the time duration that the relay will remain 'ON' Setpoint is entered in seconds.

Totaliser

When the 'Miscellaneous Function' is 'Totaliser' two setpoints are required.

Name

This displays the name given to the relay in the Relay Configure screen.

Setpoints

The Setpoints are used to determine 'When' and for what 'Duration' the relay will operate for, as shown in the table below.

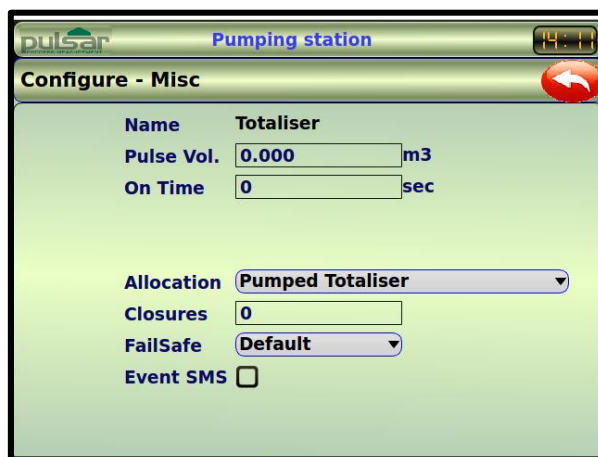

SETPOINTS	DESCRIPTION
Pulse Vol	This determines the factor by which the on board totaliser should be multiplied by to provide a relay closure . For example, if the Totaliser is totalising in litres and you require a pulse every cubic litre then a factor of 1000 would be entered. Setpoint is entered as a multiplication factor of the on board totaliser.
On Time	Determines the time period of the relay pulse . Setpoint is entered in seconds.
Allocation	This allows you to assign the relay to a Pumped volume or a totaliser from an OCM app. Select the point of measurement from the drop-down list.

Other Parameters

NAME	DESCRIPTION
Closures	The Ultimate will record how many times each relay has operated and display the number of times the relay has activated since the relay has been in use in this box. It can be reset with any value
Failsafe	<p>The unit has a general fail-safe selection option in 'Display-Failsafe'. However, this can be overwritten so that each individual relay has its own independent fail-safe mode as follows:</p> <ul style="list-style-type: none"> • Default - relay assumes the default mode as set in Display-Failsafe. • Hold – relay will remain in its current state. • De-energise – relay will de-energise. <p>Energise – relay will energise</p>
Event SMS	This option when selected will allow an SMS message to be sent to a remote telephone number as set in Remote Alarms, detailing the date, time, site ID, level and relay status at the time the message is sent.

Logical

Function

The Logical relay function is used to assign a relay output to a programmed logic point (see Chapter 4.15 Logical Output for more information)

Having selected 'Logical' as the relay 'Type' you will be presented with the screen detailed to the right.

Name

If required you can enter a name for the Logic relay function in the 'Name' field.

Next you need to determine the '**Function**' that the control relay will respond to.

To select the '**Function**' you require, select it from the dropdown box under '**Function**'.

The Function allocates the relay to a programmed logic point. The names of all logic points will be listed here that have been set up in '**Logical Output**' (up to 20).

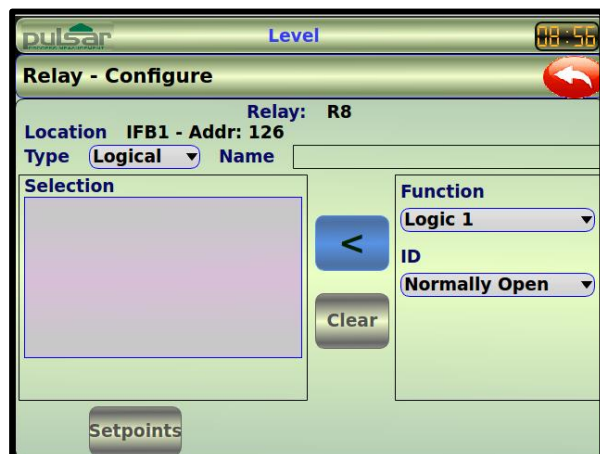

ID

When the Logical Function is selected an 'ID' must be assigned to the relay

To select the 'ID' you require, select it from the dropdown box under 'ID'.

When the function **Logic** is selected then the 'ID' is used to determine if the relay is to be used to control a **Normally Open** condition or a **Normally Close** condition.

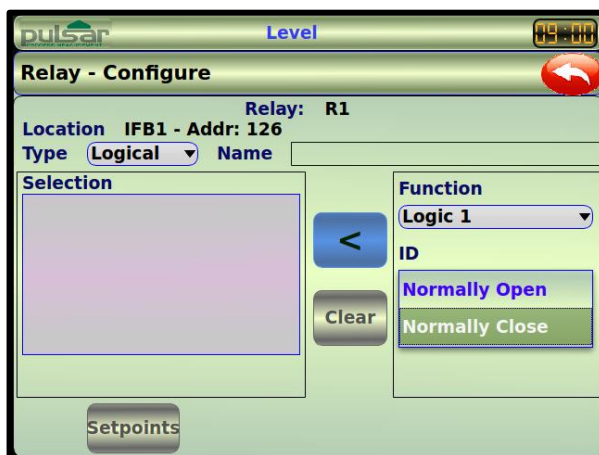

Setpoints

Once the required 'Logical Function' has been selected, the next step is to enter the setpoints for the function chosen.

To gain access to the 'Setpoints' press the < button at which time the 'Setpoints' button will change from being greyed out to being highlighted blue, selecting the highlighted **Setpoints** button will take you to the following screen.

Logical

When the 'Logical Function' is selected, two setpoints are required.

Name

This displays the name given to the relay in the Relay Configure screen.

Setpoints

The Setpoints are used to determine the 'ON' and 'OFF' points for the relay as shown in the table below.

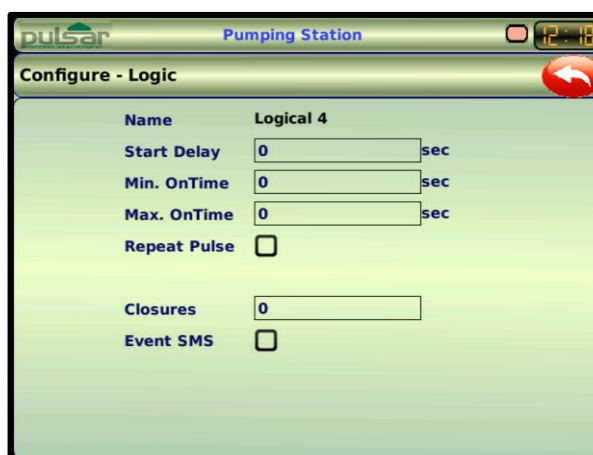

SETPOINTS	DESCRIPTION
Start Delay	Determines the time duration in seconds before the relay will energise.
Min. On Time	Determines the minimum time duration that the relay will remain 'ON' Setpoint is entered in seconds.
Max. On Time	When the logic point is active, this determines the maximum time duration that the relay will remain ON before de-energising and re-entering the start delay. A setting of zero gives infinite ON time.
Closures	The Ultimate will record how many times each relay has operated and display the number of times the relay has activated since the relay has been in use in this box. It can be reset with any value
Event SMS	This option when selected will allow a pre-determined message to be sent to a remote telephone number as set in Remote Alarms, detailing the date, time, site ID, level and relay status at the time the message is sent.

4.4 Pump Advanced

On the Main Menu screen select 

Once selected the 'Advanced Control Menu' will appear, as shown below, this screen allows access and set up of the various 'Advanced' pump features available, each of which are described below.

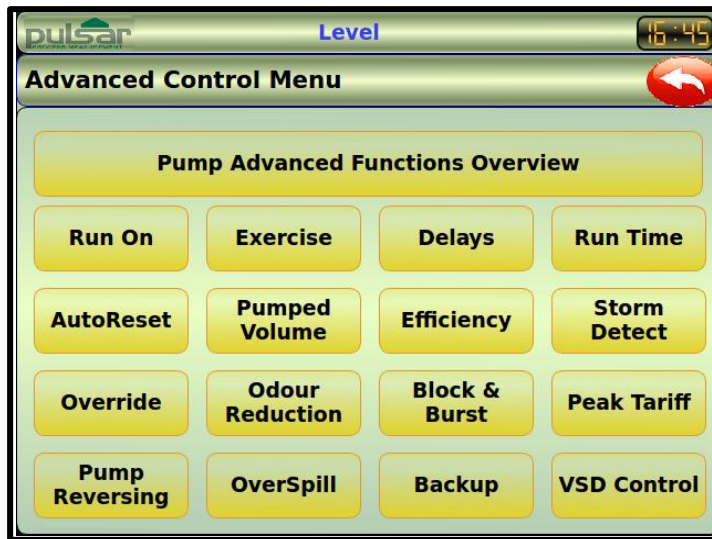

Run On

From the Advanced Control Menu select 

This feature is used to periodically allow the pumps to continue operating below their normal "OFF" point, in order to discharge any sediment that may have settled at the bottom of the vessel.

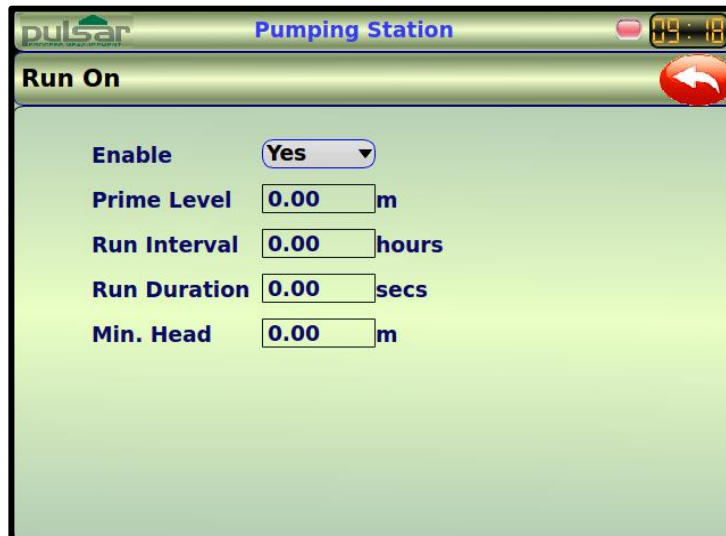

Enable

Determines whether Run On is active or not.

Prime Level

Sets the required level to ensure pumps are fully primed after a pump run on has occurred. Following a pump run on, any pump, whose "ON" point is below the Prime Level will be held "OFF" until the Prime Level has been exceeded.

Run Interval

Set required time period, in hours, at which pump run on should occur.

Run Duration

Sets the length of time, in seconds, that pumps will run on for, it should be noted that only one run on is allowed per Run Interval.

Min Head

Sets the minimum level (head) of material that must be present before permitting pump Run On to take place.

Exercise

From the Advanced Control Menu select 

This feature is used to reduce idle pump corrosion and sediment build up. Pumps are allowed to run after a specified **Idle Time** for a determined period of **Exercise time**, providing a **Minimum head /level** is present and all other pumps are switched off.

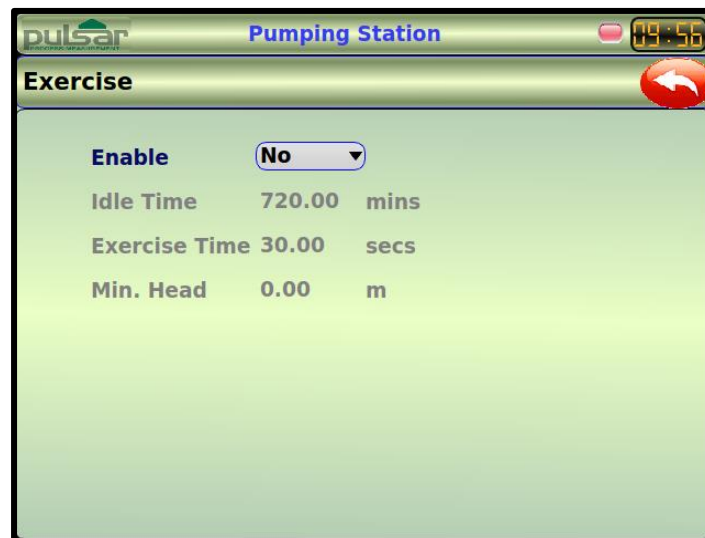
**Enable**

Determines whether Exercise is active or not.

Idle Time

Sets the Idle Time to elapse before Pump Exercising is to be activated. Set the required time period in minutes. Default = 720 minutes

Exercise Time

Set the required Exercise Time in seconds. Default = 30 seconds

Minimum Head

To prevent the dry running and the possibility of cavitation, of the pump, enter the minimum level (head) of material, in metres, that is to be present before permitting pump exercising to take place.

Delays

From the Advanced Control Menu select Delays

This feature is used to reduce the effects of power surges, caused by switching of pumps, in the following instances, **(Start Delay) Power surge** (mains or hydraulic) that is generated when multiple pumps are started simultaneously, **(Power Delay) Power resumption** following a power failure.



Enable

Determines whether Pump Start & Stop Delay is active or not.

Power Delay

Set the required time period, in seconds, that should elapse before pumps are allowed to start following recovery from a power failure. Default = 10 seconds.

Start-Start Delay

Set the required time period, in seconds, that should elapse between pumps starting. Default = 10 seconds.

Stop-Stop Delay

Set the required time period, in seconds, that should elapse between pumps stopping. Default = 0 seconds.

Start-Stop Delay

If required, this feature will **prevent** pumps, with a **common set point** being switched off all at the same time pumps will be switched in turn as determined by the **delay** set in **Start-Stop Delay**. Set the required time period, in seconds, that should elapse between pumps stopping. Default = 0 seconds.

Stop-Start Delay

If required, this feature will **prevent** pumps, with a **common "OFF" point** being switched off all at the same time pumps will be switched **"OFF"** in turn as determined by the **delay** set in **Stop Delay**. Set the required time period, in seconds, that should elapse between pumps stopping. Default = 0. seconds.

Run Time

From the Advanced Control Menu select **Run Time**

This feature can be used to demote a pump to last in the duty cycle based on number of minutes run in a particular pump cycle, or the number of pump starts in a defined time interval.

For this feature to work there must be at least two pumps programmed into the unit. **Run Time** will only work if there is at least one pump that is not currently running its pump cycle (OFF) and is available to run (healthy).

Parameter	Value	Unit
Enable	Yes	
Max.RunTime	99999.00	mins
Max.Starts	99	
In Interval	9999	mins
Max. RunPumps	99	
MaxStart Override	99.999	m

Enable

Determines whether Run Time is active or not.

Max. Run Time

Sets the maximum time, in any one cycle, that any individual pump will be allowed to run, before being switched off and the duty passed to the next available pump, according to individual setpoints.

Max. Starts

Sets the maximum number of starts (cycles), in any given time interval, that any individual pump will make, before being switched off and the duty passed to the next available pump, according to individual setpoints.

In Interval

Set in conjunction with Max Starts function and will determine the period of time that Max starts is allowed.

Max. Run Pumps

Determines the maximum number of pumps that can run at any one time.

Max. Start Override

Determines the level which will be present for the unit to override Run Time operation.

Auto Reset

From the Advanced Control Menu select **Run Time**

When using digital inputs to monitor pump failure and have assigned relays to "Pump Reset", this function allows for a pre-programmed number of pump "fails" (Consecutive, or trips in a 24-hour period) to be automatically reset before putting a pump out of service.

A pump "fail" is defined as the change of state of the trip signal from normal condition to tripped. At the point of failure both the consecutive trip counter and the 24-hour rolling counter will be advanced by an increment of 1. After any such pump "fail" is observed the unit will initiate a "cooling" down period (Reset Int.) before initiating an automatic reset (Reset Pulse).

At this point, the pump has been reset and will operate as normal the next time its 'ON' setpoint is reached. If the pump then successfully pumps to its 'OFF' setpoint, thereby completing a successful pump cycle, then the consecutive trip counter will be reset and the 24-hour rolling counter preserved. When any Pump Trip counter equals the number of trips allowed (24hr Trips) in any rolling 24-hour period, starting with the first increment of the Trip counter or the pump fails consecutively, exceeding the number of consecutive trips without completing a successful pump cycle, that pump will be put out of service and will not be rest until such time that the fail condition is removed.

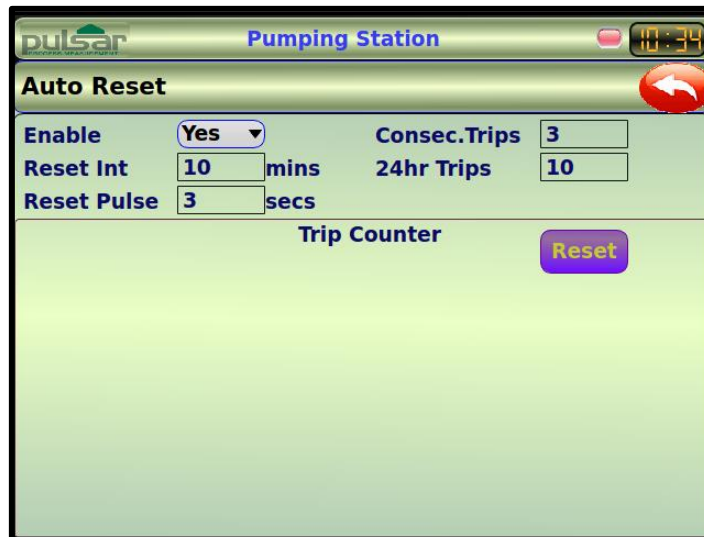

Enable

Determines whether Auto Reset is to be used or not.

Reset Interval

Sets the "cooling" off period prior to the Reset Pulse being initiated.

Reset Pulse

Determines the duration of the Reset Pulse.

Consec. Trips

Sets the number of consecutive pump "fails" that can be automatically reset before putting a pump out of service.

24hr Trips

This parameter sets the maximum number of pump "fails" allowed in any 24-hour rolling period.

Trip Counter

This displays the number of times that a pump has 'tripped' since the last successful Reset was performed. You can reset the Trip Counter by selecting **Reset**

Pumped Volume

From the Advanced Control Menu select **Pumped Volume**. This feature totalises the volume pumped in the application.

The source for the volume can be a flow measurement point, the flow measurement associated with pump relays, or derived via the rate of change in level and the volume profile of the pumping vessel.

Pumped Volume		Pump Totaliser Logs	
Source	Derived Flow	Date	Totaliser
Settle Time	60 secs		
Outflow Limit	10 l/sec		
Allocation	None		
Totaliser Unit	litre		
Multiplier	*1		
Decimals	2		
Daily Log Time	00 : 00		
Daily Tot	0.00		
System Tot	0.00		
Resettable Tot	0.00		

Source

Determines the **source** that is used to provide the volume data in order to calculate the pumped volume, there are a total of three sources available each of which are described below.

Pumped Volume		Pump Totaliser Logs	
Source	Derived Flow	Date	Totaliser
Settle Time	60 secs		
Outflow Limit	10 l/sec		
Allocation	None		
Totaliser Unit	litre		
Multiplier	*1		
Decimals	2		
Daily Log Time	00 : 00		
Daily Tot	0.00		
System Tot	0.00		
Resettable Tot	0.00		

Derived Flow

Derived Flow is used in conjunction with a **volume profile** in order to provide a calculation of **pumped volume** and you will need to set up the volume profile before using Derived Flow to provide a calculation of pumped volume. Derived Flow is the method of calculating the flow rate based on the rate of change in level. While the pumps are not running, the inflow is calculated by taking an average of the rate of change. At the point when a pump cycle begins the inflow value at that point is used as a constant for the inflow throughout the pump cycle. The rate of change whilst the pump is running is then calculated and added to the inflow rate to give the pumping rate. This pumping rate is then multiplied by the calculated volume between the pump ON and OFF point to give the pumped volume.

Pumps

To use the Pumps option to provide Pumped Volume **each pump** must have a flow measurement point.

FlowPulse

To add a FlowPulse to the system go to **Advanced Config > Modules > Add FlowPulse**

To setup the FlowPulse go to **Setup > Sensors > FlowPulse** to set up the FlowPulse.

To allocate the FlowPulse to a pump go to **Setup > Main Menu > Relays > Configure > Setpoints** and allocate the appropriate FlowPulse to the relevant pump.

mA Input device

To add a mA Input device, go to **Setup > Application > mA Inputs** and name and set up device.

To create a measurement point for the device, go to **Setup > Application > Operation > Mode to Flow > Allocation** to the appropriate mA Input or device name if given.

Flow Device

Will use a **single flow device** such as a FlowPulse or a device suitable for connecting via the mA input, allocate to a **common outlet**, with the setup of such devices being as above.

Settle Time

Determines the time allowed for the level to settle after all pumps have switched Off, to avoid any effects of flow back or turbulence, before commencing the calculating of the Inflow Rate.

Outflow Limit

Determines the maximum limit for the outflow in ltrs/sec.

Allocation

When the source is **Derived Flow**, allocation determines which **volume profile** is used to calculate **volume**.

When source is **Pumps** and the flow measurement is provided by Flow Pulse sensors, Allocation selects a volume profile to calibrate the Flow Pulse sensors against. Calibration is set up in the Asset management - Pump Predictive Maintenance menu.

When the source is **Flow Device**, **allocation** determines which **measurement point** will provide the **flow rate**.

Totaliser Unit

Determines the volume units that pumped volume is measured and totalised in.

The choices of units are detailed in the table below.

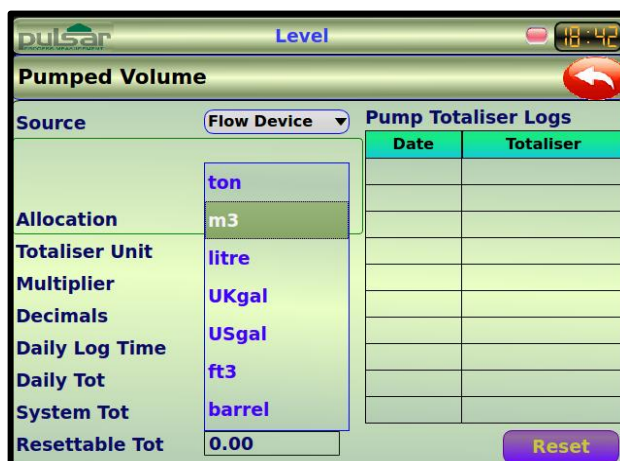

SETPOINTS	DESCRIPTION
Ton	Volume will be calculated and displayed in Tons
Tonne	Volume will be calculated and displayed in Tonnes
Cubic metres (M ³)	Volume will be calculated and displayed in Cubic metres (M³)
Litres	Volume will be calculated and displayed in Litres
UK Gallons	Volume will be calculated and displayed in UK Gallons (UK gal)
US Gallons	Volume will be calculated and displayed in US Gallons (US gal)
Cubic Feet (ft ³)	Volume will be calculated and displayed in Cubic Feet (ft³)
Barrels	Volume will be calculated and displayed in Barrels
Pounds (lbs.)	Volume will be calculated and displayed in Pounds (lbs.)

Multiplier

This determines the **factor** by which the actual **flowrate** will be **multiplied** before incrementing the **totaliser**. This is just a multiplier of volume. If you wanted to totalise in tens of cubic metres, you would select cubic metres and then select *10.

Decimals

Determines the number of decimal places used in the reading during run mode.

Daily Log Time

Sets the time of day when the daily totaliser will start a new day from zero and the previous daily totaliser is incremented into the Pump Totaliser Log. The start time should be entered in 24-hour clock format.

Daily Totaliser

Displays the current value of the daily totaliser. This cannot be reset in run mode, only by accessing Pumped Volume and entering zero into the **Daily Totaliser** box can you reset this totaliser.

System Totaliser

Displays the current value of the, non-resettable totaliser. During run mode, this totaliser can be viewed via the **Totaliser** hot key '**Σ**'. Unlike the resettable totaliser this cannot be reset whilst in run mode, it can however be reset whilst in program mode by accessing Pumped volume and entering zero in the **System Totaliser** value box.

Resettable Totaliser

Displays the current value of the resettable totaliser. During run mode, this totaliser can be viewed via the **Totaliser** hot key '**Σ**'. The resettable totaliser can also be cleared by pressing the clear button in the hot key menu displayed.

Pump Totaliser Logs

When Pump Volume is enabled, the **Pump Totaliser Log** table shows the date and pumped volume total for the last ten days, the first on the list are the most recent and last ones are the oldest. When all ten total audits are full the oldest is pushed out and all totals increment through to allow the new days total to be registered in the first day's total audit parameter allocation.

To clear the logs recorded, pressing the **Reset** button enables all of the Total Audits in the log table to be cleared to factory default values.

During **Run Mode**, you can view the totaliser values by pressing the '**Σ**' hot key, from here the resettable totaliser can be reset by pressing the **clear** button which will revert the value back to 0.

Efficiency

From the Advanced Control Menu select Efficiency

This feature uses the rate of change in level to use the most efficient pump(s) that are available to use as determined by comparison to the value for the pumps Calibrated Throughput as detailed in **Relays > Type > Pump Setpoints > Calibrated Throughput**. Any pumps that are not deemed to be running efficiently can be **demoted** and placed at the end of the pumping cycle so that the most efficient pumps are allowed to run first. When first enabled, the pumps will need to be calibrated to set the initial efficiency as 100%. The calibration is initiated in the **Asset Management > Pump Predictive Maintenance** menu.



Enable

Determines whether Pump Efficiency is used or not.

Demote Pump

When an efficiency alarm is being used this option will determine if a pump is to be demoted to the last pump in the duty cycle on activation of the alarm. When Demote Pump is enabled, and the efficiency alarm is activated after the predetermined **Persist Count** the inefficient pump will be set to the last pump in the cycle which will be called to start if the level reaches the on point for that pump. A pump which has been demoted will be indicated by the relevant "pump" icon "flashing" RED.

Sample Rate

Determines how often the unit will check to see if a change of level has occurred in order to calculate a rate of change.

Persist Count.

If an alarm is to be used to indicate when the Pump efficiency falls below a predetermined level, this parameter determines the number of consecutive times the pump will be allowed to run at the reduced efficiency, before the alarm will be activated and the pump demoted if required.

Eff. Delay

Used to set a delay, after all pumps have stopped, to allow for any turbulence of the material surface to settle prior to monitoring the level in the vessel and determining the inflow before the next pump cycle commences. The delay time is entered in seconds and the default is 45 seconds.

Important Information

When setting the **time period** for the **Eff. Delay** it is important that it does not **exceed** the **time from** when all pumps switch **Off** to the first pump **Start** during **normal operation** as it will prevent **determining** the **Inflow** and any subsequent **calculation of Efficiency**.

Eff Delay 1

Sets the time duration over which the pumps performance will be monitored, and the resulting efficiency is calculated.

Storm Detect

From the Advanced Control Menu select 

For this feature to operate a relay must have been assigned to 'Control', 'Storm' and have Storm and Reset Level setpoints programmed.

This feature enables all pumps to be **disabled** during a storm condition to prevent the futile running or potential damage due to the continued use of pumps during flood conditions. Provision is also made to allow a maximum **disable time** for which pumps will remain disabled during such conditions.

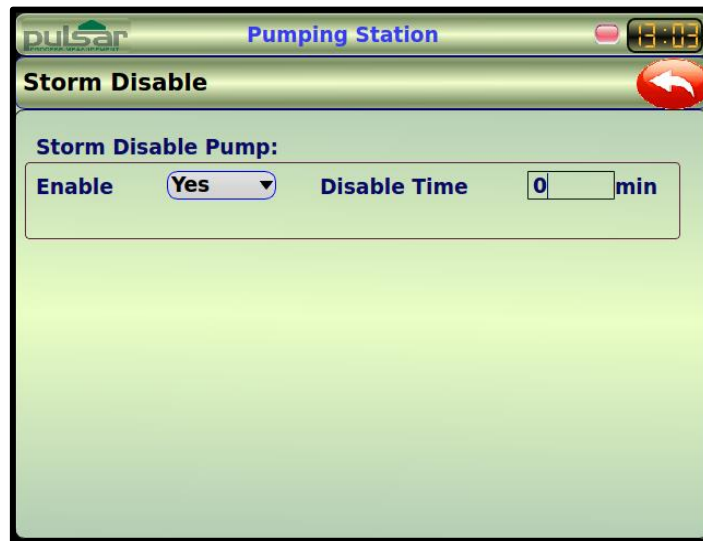

Enable

Determines whether Storm Disable is to be used or not.

Disable Time

Sets the maximum time pumps will remain disabled. Enter desired time in minutes, please note that if the Disable Time is set to zero Storm Disable will be inoperative.

Override

From the Advanced Control Menu select **Override**

Used in conjunction with the **Digital Input** features 'Override On' and 'Override Off' and allows the pumps setpoints to be overridden to the chosen state provided that the level is above a minimum level and following a set delay.

To setup a Digital Input for Override go to **Set up > Digital Inputs > Select Input > Configure > Assignment = Pump > Function = Override ON or Override OFF.**



Enable

Determines whether Override is to be used or not.

Override Delay

Determines the delay, in seconds, from first seeing the Min. Override Level, after which the pumps setpoints will be overridden to the chosen condition, On or Off, as determined by the Digital Input.

Min. Override

Sets the minimum level, in measurement units that is required before the Override Delay starts its count down and an override condition can be put into effect.

Odour Reduction

From the Advanced Control Menu select **Odour Reduction**

This screen allows you to enable the functions **Wall Cling** or **Septicity Prevention**, which reduces the amount of material build up and/or reduce the amount of corrosion or gas build up in a sump or vessel.

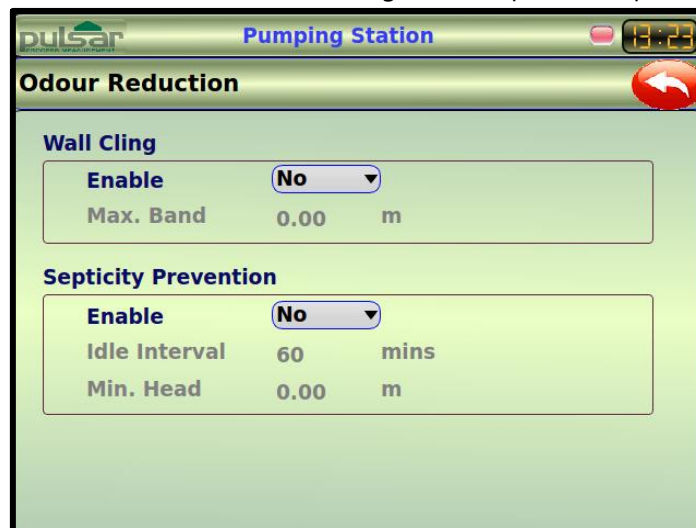

Wall Cling

To reduce material build up, (such as fat), on the wall of the sump or vessel, at the 'normal' material level the pump setpoints can be varied within a specified band.

For Pump Down applications the relay setpoints for the pumps will be randomly varied within the band specified, somewhere below ON, but to a maximum of the setting, and somewhere higher than OFF, but to a maximum of the setting.

For Pump Up applications the relay setpoints for the pumps will be randomly varied within the band specified somewhere higher than ON, but to a maximum of the setting, and somewhere lower than OFF, but to a maximum of the setting.

Enable

Determines whether Wall Cling is to be used or not.

Max. Band

Enter the maximum band of variation required, in measurement units.

Septicity Prevention

If all pumps have been idle for a period of time and the level is above a minimum level, then the duty pump will be allowed to start and pump until it reaches the minimum level in order reduce the amount of corrosion or gas build up in a sump or vessel.

Enable

Determines whether Septicity Prevention is to be used or not.

Idle Interval

Sets the time period, after which all pumps have switched off, that has to elapse before Septicity Prevention will become active.

Min. Head

Determines the minimum level, above which the material must be, before Septicity Prevention will operate, once the material level falls to the Min. Head Septicity Prevention will become inoperative.

Block & Burst

From the Advanced Control Menu select



This feature is used to detect a **Burst** or **Block** condition and provide an **alarm** and works in conjunction with an **RMA** (Rising Main Alarm) see **Relays > Function > Alarm > ID > RMA**.

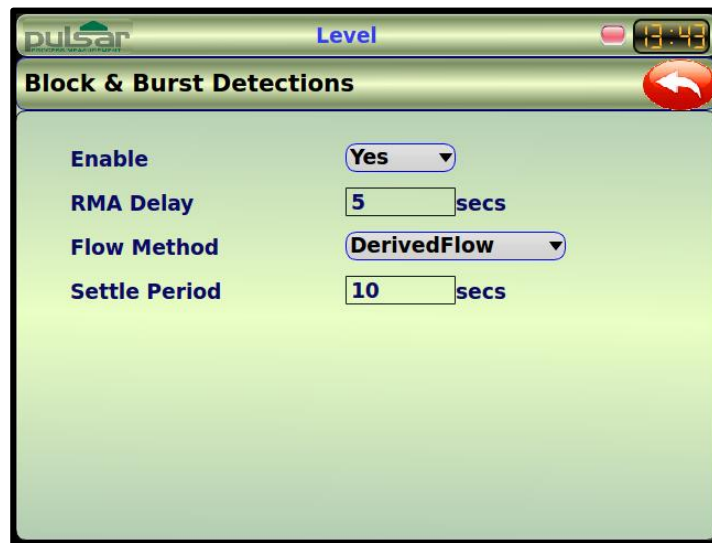

Enable

Determines whether Block & Burst detection is to be used or not. Please note that if Block & Burst is not enabled then any RMA alarms set will be inoperative.

RMA Delay

Time duration from the first pump start to allow the RMA alarms to be active. This gives time for the rate of change or FlowPulse input to settle at the pumping rate before allowing the alarms to be operational that a Block has to be present before initiating an alarm condition.

Flow Method

Select the method by which the flow rate is to be calculated.

Derived Flow

Uses the method of calculating the flow rate based on rate of change in level, and the volume profile of the well (Volume required). While the pumps are not running the inflow is calculated by taking an average of the rate of change. At the point in which a pump cycle begins the inflow value at that point is used as a constant throughout that cycle. The rate of change throughout the pumping cycle is then subtracted from the inflow to give the pumping rate/flow.

FlowPulse

FlowPulse sensors are used to provide real time flow rate data.

Settle Period

This determines the time period allowed for the level to settle after the first pump has switched on before calculating the value of derived flow.

Peak Tariff

From the Advanced Control Menu select **Peak Tariff**

This feature is used to reduce or avoid the use of pumps during high tariff periods by continually monitoring the level and inflow conditions of the well and optimise the level and intelligently control the pumps according to any impending tariff changes.

No.	Day	Week	Start Date dd/mm	End Date dd/mm	Start Time hh:mm	EndTime hh:mm
1	Off	1				
2	Off	1				
3	Off	1				
4	Off	1				
5	Off	1				

Enable

Determines whether Peak Tariff is in use or not.

Lead Time

Determines the time, prior to a Peak Tariff period, at which the vessel will be pumped down to the lowest pump OFF level.

Min. Run

Determines the minimum amount of time that a pump will be allowed to run during a Peak Tariff period, if required, and is used to prevent excessive wear or damage to the pump.

Ovf Level

Determines the maximum level to which the vessel will be allowed to fill. Should this level be reached all pumps will be switched ON, according to their setpoints and pump duty, to draw the level down, as required, irrespective of the control sequence in operation.

Lag Time

Determines the time, after a Peak Tariff period, that the vessel will be pumped down, (if required), by the first duty pump to the lowest pump Off level. If after the Lag Time has expired the pump has not reached its Off point it will continue to pump until the Off point is reached. On expiry of the Lag Time all pumps will assume their normal operation and will be switched On and Off according to their respective setpoints.

Minimum Head

Determines the minimum head (level) of material required to be present before a pump will be allowed to run, if required, during a Peak Tariff period and is used to ensure that a prime level for the pumps is maintained.

Peak Tariff periods

Up to ten separate Peak Tariff periods can be programmed in to the unit, these periods can be set for a specific date and time or at a specific time during a period of dates or on a daily or weekly basis.

Day

Determines the **day** on which the "Peak Tariff" period will be in effect.



Week

Determines the **week** in which the "Peak Tariff" period will be in effect.



Start Date

From the pop up calendar select the **date** on which the "Peak Time" will **start**.

End Date

From the pop up calendar select the **date** on which the "Peak Time" will **end**.

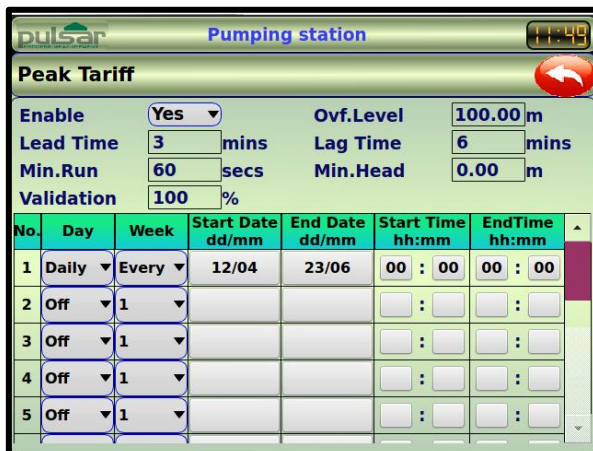

Start Time

Sets the **time** at which the "Peak Time" will **start**.
Enter the desired time in HH:MM format

End Time

Sets the **time** at which the "Peak Time" will **end**.
Enter the desired time in HH:MM format

No.	Day	Week	Start Date dd/mm	End Date dd/mm	Start Time hh:mm	EndTime hh:mm
1	Daily	Every	16/03	24/05	18 : 00	19 : 00
2	Off	1				
3	Off	1				
4	Off	1				
5	Off	1				

Pump Reversing

From the Advanced Control Menu select



The Pump Reversing feature provides a pump pre-blockage detection algorithm and provides a choice of remedial actions triggered from the detection. A pump can be momentarily stopped to allow the reflux flow to clear the impellor, or if the pump allows, could be reversed to free any potential blockages. If pre-blockage detections are happening repeatedly, the pump can be demoted to last in duty. The feature continually compares the pump's electrical current profile to a stored "calibration" profile, which means that an initial calibration cycle is required (per pump) when the pump is deemed to be in good running condition.

For further information and installation details see separate manual supplied with unit.



Setup Pre-requisites

- **Level** measurement point, to control pumps and provide data to the reversing algorithm.
- Pulsar Power monitor with a reversing feature registered on the PBUS Hardware Expansion port and declared as a **power** measurement point. (one per pump)
- Relay configured for pump control to Start/Stop the pump, with its **Power** parameter set as the power measurement point for monitoring that specific pump (one per pump)
- If Pump reversing is required, a Control Relay with a function of pump reverse needs to be configured (one per pump)

Each Pump has its own set of identical pump reversing parameters, which can be accessed using the tree list on the left-hand side of the screen.

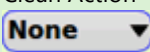

CONTROL/PARAMETER	DESCRIPTION
Pump Pump 1	Indicates which pump is currently selected.
Enable Yes	Yes = RetroFlo feature Enabled No = RetroFlo Feature Disabled (Default)
Action	Stop on Blockage = If a blockage is detected then the pump will be stopped. Reverse on Blockage = If a blockage is detected then pump will reverse. Reverse on Start = Before a pump starts the pump will reverse for a set amount of time. Reverse on Fault = The pump will be reversed when failed input is removed
Demote Pump No	If the Block count reaches the Max Seq. Value. The pump can be demoted to last to start in the duty order. No = Pump will not be demoted (Default) Yes = Pump will be demoted
Max. Seq.	Sets the Maximum Pump Stop or Pump Reverse Sequences that will be allowed to occur before demoting the pump. Range: 0 -> 9999 Default: 3
Stop Duration	This defines the duration the pump is stopped for, following a pre-blockage event, or a pump reversal.
Rev. Duration	This defines the duration of the pump reversal. Range: 0 -> 99999 Default:10 (seconds)
Reverse Rel. None	This list box selects which Pump Reversing Relay is used to reverse the currently selected pump. The list will only show the available relays.
Deadband	Sets the electrical current threshold above and below the stored calibration that triggers the pre-blockage detection event. Range: 0 -> 100 Default 20 (%)
Block Count	Total number of pre-blockage events detected.
Flush Valve No	If the pump has a flush valve fitted, an extra time delay can be added from the pump start to the start of pre-blockage monitoring. No = No Delay added (No flush valve) Yes = Delay added (Flush valve fitted)

CONTROL/PARAMETER	DESCRIPTION
Min Head	Minimum level required in the well before can be started without becoming air locked. Range: 0 -> 99 Default: 0 (metres)
Monitor Delay	Delay time from the pump start to when the motor current starts being monitored. This is to prevent acting on spurious current readings as the pump starts. Range: 0 -> 99999 Default: 5 (Seconds)
Persist Time	Sets the persistence time of the pre-blockage conditions before triggering the pre-blockage event. Range: 0 -> 99999 Default: 2 (seconds)
Operation Time	Flush Valve Operation time sets the duration of the Flush Valve delay. Range: 0 -> 99999 Default: 3 (seconds)
Clean Action 	When a pre-blockage is detected, the Clean action parameter sets what action to take. None = Take no action (Default) Stop = The pump will be stopped for a definable period (Stop interval) before starting again. Reverse = The pump will be stopped for the duration of the Stop interval, then reversed for a definable period (Reverse Int.). The pump is then stopped for the stop interval, then started to continue pumping.
Num. Clearance	Number of Clearances totalises the number of Successfully cleared pre-blockages.
Clear Counts 	Clears the Num. Clearance and Block Count totalisers.

Calibration

Each pump needs to be calibrated when commissioning the RetroFlo feature. Each pump should be in its normal healthy running condition to set the "benchmark" for subsequent pump runs to be compared. The calibration process allows the well to fill to a pre-determined level and then run the pump to its programmed stop level. Pump calibration is initiated from within the **Assets Management > Pump Predictive Maintenance** menu.

Over Spill

From the Advanced Control Menu select **OverSpill**

The Over Spill feature is used to calculate and predict a potential Over Flow condition and provide an alarm as set in **Relays > Alarm > Overflow** alarm.

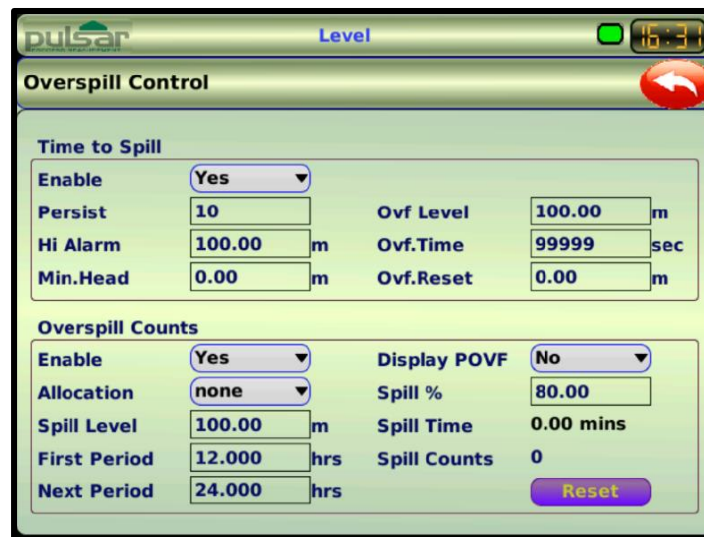

Time to Spill

Enable

Determines whether Time to Spill detection is to be used or not. Please note that if Over Spill is not enabled then any Overflow alarms set will be inoperative.

Persist Time

Determines the persistence for the Time to Spill, or the reset condition to be exceeded before the alarm changes state.

Hi Alarm

Sets a level in **measurement units** at which the Overflow alarm will activate as a High alarm regardless of the calculation of time to spill, this level should be set the same as the OVF Level or just below.

Min. Head

Determines the level in **measurement units**, below which the calculation to time to Overspill will be suspended and the Overspill function disabled.

OVF Level

Determines the **Overflow Level** (OVF Level), this is the level in **measurement units** at which an overflow would occur and is the level that will be used to calculate the time to overflow.

OVF Time

Determines the time, prior to a potential overflow occurrence, at which the alarm will activate if it is calculated that an overspill is likely to occur.

OVF Reset

Determines the point the level in **measurement units** has to be below (or fall below) before an activated alarm can be considered to be deactivated, provided the calculated time to overflow is not less than the OVF Time. And the level is below the OVF Reset, the alarm will turn OFF.

Overspill Counts

This feature will function independently to the Time to Spill which does not have to be enabled for Overspill Count to work. If enabled, Overspill counts will record that a spill event has taken place in each time period and accumulate the total Spill time of each event, an Overspill Count is initiated when the level goes above the Spill Level and the Spill Time is the time that it remains above the Spill Level.

Enable

Determines whether Overspill Count is to be used or not.

Allocation

Sets the Point of Measurement to which the Spill Count will relate to.

Spill Level

Sets the level in **measurement units** at which an Overspill will occur, and at which point the Overspill Count will be initiated.

First Period

Determines the length of time, in hours, of the First Period, typically 12 hours. When a spill first occurs, the First Period will start. The Spill Count will be advanced by 1 and the Spill Time will be recorded for the duration of the spill, should any subsequent spill events occur, in the First Period. Then the counter will not be incremented, but the time spent in a spill condition will be added to the Spill Time. At the end of the First Period, the Next Period will begin.

Spill Count and **Spill Time** are **read only**, and their values cannot be changed other than being Reset to zero by using the  button.

Next Period

Determines the length of time, in hours, of the Next Period. If a spill occurs within the Next Period, the spill count is incremented by 1 and the duration of the spill added to the spill time. Any subsequent spills within the Next Period will not increment the spill count, but the duration will be added to the spill time. If a spill has occurred within the next period, the current Next Period will be followed by another Next Period. This will continue until there is a Next Period without any spill events. The next spill will then start a First Period.

Display POV

In the event of an overspill, you can turn on/off an icon to appear on the main display.

Spill %

The percentage of the spill level that must be present for an overspill condition to be present.

Backup

From the Advanced Control Menu select Backup

The Backup function is used in conjunction with digital inputs where a float switch or similar contacting device will be assigned to an input.

This feature can be used alongside a transducer or as a backup method for when a transducer goes into failsafe. The high input has a persist timer and a level set point, which will allow for the unit to run the pumps according to the pump routine below the setpoint for the specified amount of time. The low input will simply switch off all the pumps set on the controller.



Enable

Determines when Backup will be used as detailed below.

OPTION	DESCRIPTION
No	Backup is not used
Always	Backup will be active continuously and will respond to an input from a Backup device at all times.
Failed Only	Backup will only be active at times when the unit has gone into a 'Failsafe' mode

Up to two **Backup Hi** devices and two **Backup Lo** devices are able to be set (see **Digital Inputs > Backup**).

Hi Switch 1 will display the Digital Input to which the Backup Hi 1 device has been allocated.

Hi Switch 2 will display the Digital Input to which the Backup Hi 2 device has been allocated.

Lo Switch 1 will display the Digital Input to which the Backup Lo 1 device has been allocated.

Lo Switch 2 will display the Digital Input to which the Backup Lo 2 device has been allocated.



Hi Level 1

If Hi Switch 1 activates a Backup Condition Hi Level 1 will determine the level that the unit will assume is present and switch on pumps in accordance with their setpoints.

In the case of a pump down application only pumps that have their ON setpoints below the level set by Hi Level 1 will be allowed to start when a Backup condition is by Hi Switch 1 so the setting of Hi Level 1 can be used to determine the number of pumps that will start when a Backup condition is present.

Hi Level 2

Acts in the same way as Hi Level 1 but at a different level.

Pump Time

Determines the period of time that the pumps will be allowed to run once a Backup condition has been initiated.

Persist Time

Determines the time that a Backup signal has to be present on the Digital Input before a Backup condition will be activated.

VSD Controls

From the Advanced Control Menu select **VSD Control**.

Variable **S**peed **D**rive Controls function uses a PID control loop to modulate an output to control a VSD (or proportional control valve) to maintain a pre-determined value of process variable. The process variable is chosen from any of the available measurement points. The VSD needs to be associated with a pump control relay (assigned in relay set points page), and the mA output used for control needs to be allocated to VSD.

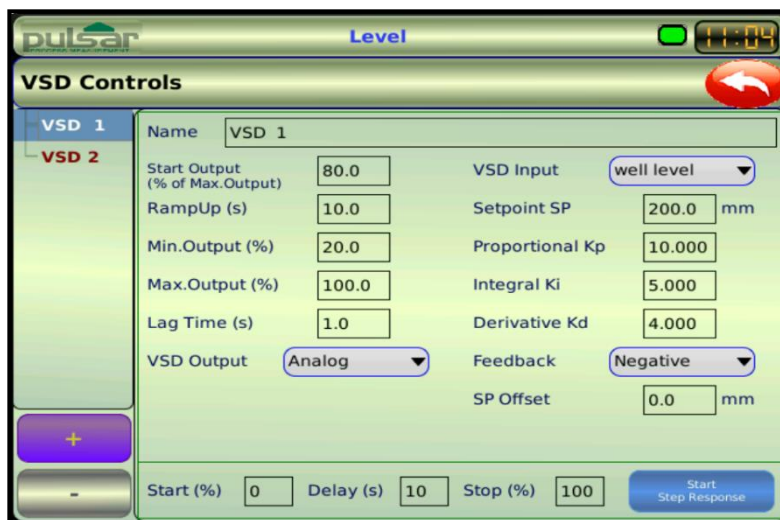

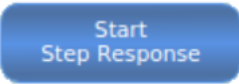
OPTION	DESCRIPTION
Name	If desired, enter a name for the VSD Control in the 'Name' field.
Start Output (% of Max Output)	When Pump relay energises, the control output will change from the Min Output to Start Output before handing control of the output to the control loop.
Ramp Up (s)	Time taken to ramp the control output from the Min Output to the Start Output .
Min. Output (%)	Minimum percentage of output allowed during control
Max. Output (%)	Maximum percentage of output allowed during control
Lag Time (s)	The response time of the input to a change in output. Use a larger value for slower responding systems.
VSD Output	Analogue (mA output) or Digital (RS485 Modbus)
VSD Input	Measurement points to be controlled by the PID loop
Setpoint SP	Desired control setpoint in units of measurement
Proportional KP	Proportional control constant.
Integral Ki	Integral control constant.
Derivative Kd	Derivative control constant.
Feedback	Positive - an increasing control output will increase the VSD input variable (e.g., Pump flow control). Negative – an increasing control output will decrease the VSD input variable (e.g., Pump down level control)
SP Offset	Used to correct steady state errors.
Proportional KP	Proportional control constant.
Step Response Test	
Start (%)	Start output percentage for the step response test
Delay (s)	Time delay before step change.
Stop (%)	Stop output percentage for the step response test
	Initiate Step response test. The test is conducted from this screen and the input and output control data is sent to the separate PID tuning software which will determine suitable values for the PID control constants.

Setup

There are several methods of determining the loop control constants for PID control, but for pumping applications, just using proportional control may give satisfactory results.

1. Allocate the Pump Relay and mA output to the VSD control.
2. Select the VSD input variable, output method, and feedback type.
3. Set the Output Percentage limits Start output as required.
4. For fast responding systems, set the Lag Time to 1s
5. Increase Proportional Kp (values typically from 1 – 20) until desired control is achieved.

4.5 Digital Inputs

On the Main Menu screen select 

The digital inputs are used to provide the Ultimate with information on the operational status and condition of pumps, valves, and other process control devices. Based on the information supplied, by the inputs, the Ultimate will make intelligent decisions and modify its control regime to meet the demand of the prevailing operational requirements.

The Digital Inputs Menu is used to configure any new digital inputs and to view, edit or delete existing configured digital inputs. In order to set up or make any changes to existing digital inputs you must first highlight the input required. Once the required input is highlighted the **'Clear'** and **'Configure'** buttons will become available and can be selected for use. To configure a new digital input or edit or view the configuration of an existing input press the **'Configure'** button, to delete the settings of an existing input press the **'Clear'** button and follow the on-screen instructions.

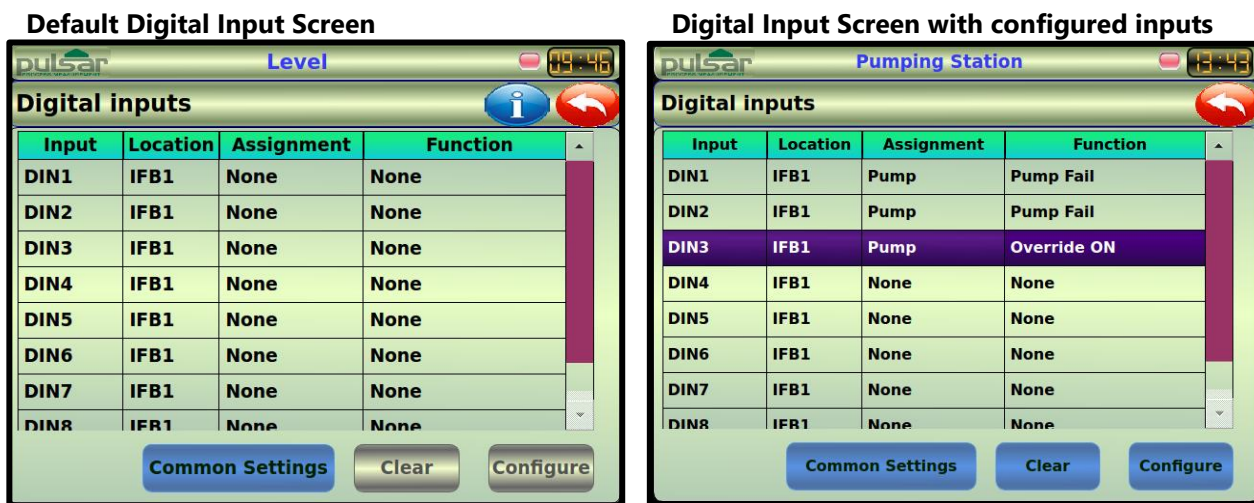

Common Settings

These parameters are common to each of the eight digital inputs and set specific operational criteria for particular functions.

To access Common Settings, select  from the main Digital Input Menu and the following screen will appear.

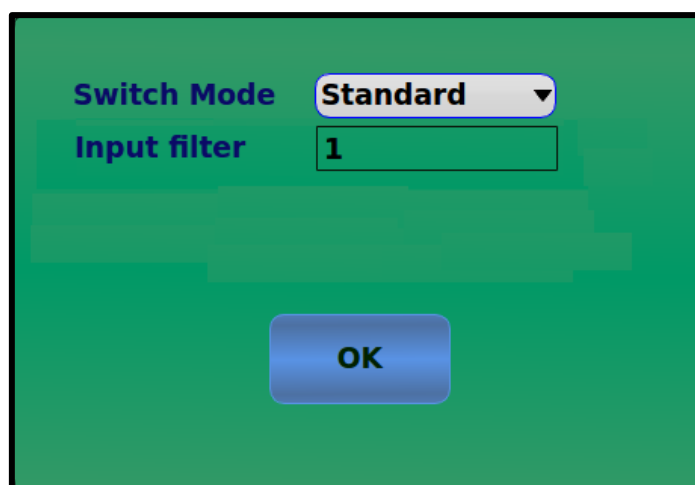

Switch mode

This function allows the digital inputs to be used to determine, via an 'auto/manual' switch, which one of the devices connected to the relay outputs, will be the 'lead' or 'duty' device.

When an external duty switch is used it is connected via the digital inputs and facilitate the selection of the duty device manually, thereby overriding the duty programmed within the unit.

There are two types of switch that can be selected from the drop-down box, as described below.

NAME	DESCRIPTION
Standard	A standard switch, e.g., rotary switch, can be used with one switch position and a digital input required for each pump.
Binary	To reduce the number of digital inputs used, for manual duty selection, a binary switch can be supplied. Max. No. of digital inputs required being four.

Input Filter

This parameter is used to ignore spurious changes of state on the digital inputs and determines the time that a change of state has to be present before it is recognised as a valid input.

Once you have selected the input you wish to use and have pressed '**Configure**' you will see the screen as detailed on the right. The screen will confirm the Input number and the Interface Board (IFB) on which it is located, in this case DIN4 on IFB1.

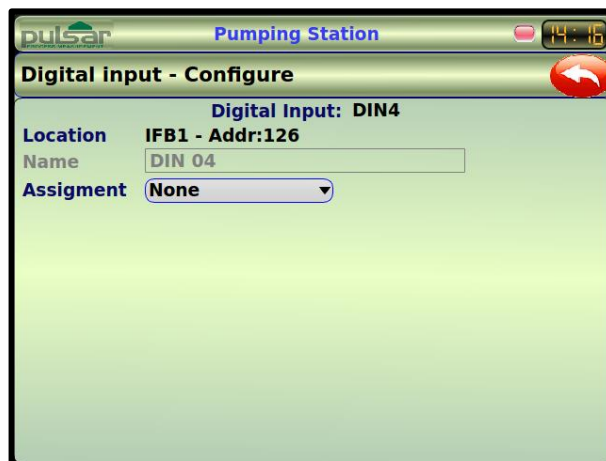

Assignment

To proceed with the setup of the input you must first assign the input to the function to which it will react as contained in the '**Assignment**' drop down box.

All inputs can be configured to any of the '**Assignment**' detailed in the following table.

NAME	DESCRIPTION
None	Digital Input is not in use
General	When selected the Digital Input is used in conjunction with an alarm relay configured as a 'Device Alarm' to provide an indication of when an external device has failed.
Pump	When selected the Digital Input is used in conjunction with relays assigned to Pump . The input can be used to indicate pump failure , to select a duty pump, override pump setpoints or to reset failed pumps.
Backup	When selected the Digital Input works in conjunction with Pump Advanced > Backup , where a device such as a Float Switch can be connected to the input which if activated will override the pump setpoints and switch the pumps ON or OFF in accordance with the setup of the Backup feature. Provision is made for up to two Backup Hi and two Backup Lo devices to be used.
Maintenance	When selected the Digital Input works in conjunction with Advanced Config > Maintenance . It is used to place the device into Maintenance mode.

General

Having selected **General** as the input **Assignment** you will be presented with the screen detailed to the right.

You can now complete the setup of the input as follows.

Name

Having selected an **Assignment** for the input, if required you can enter a name for the input in the **Name** field.

Input Type

By selecting the **Input Type** drop down menu you will be given the choice of **Active Low** input will be **active** when **no voltage** (signal) is present or **Active High** input will be **active** when a **voltage** (signal) is present.

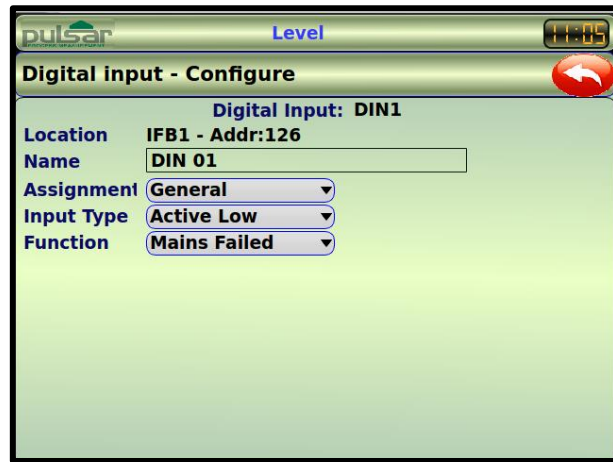

Function

Next you need to determine the **Function** that the digital input will respond to.

To select the **Function** you require, select it from the dropdown box under **Function**.

Full details of the **Functions**, and their descriptions, that are available, when the input **Assignment** is selected as **General**, are shown in the table below:

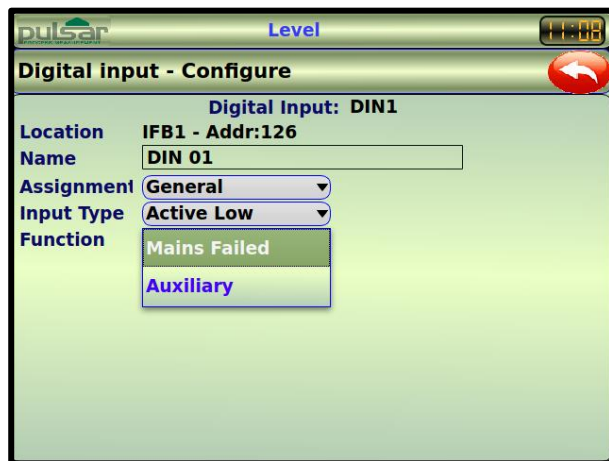

NAME	DESCRIPTION
Mains failed	Input will provide a signal indicating that there is a mains power failure or the presence of a healthy signal. This is used in conjunction with the Battery Backup unit.
Auxiliary	Input indicates the state of a device for the integral RTU, creating a logic point, or assigning a device alarm relay.

Pump

The **'Pump Assignment'** allows the digital inputs to be used to indicate pump faults and influence the pumping philosophy by overriding pumps on/off or forcing the duty to a specific pump. You can now complete the setup of the input as follows.

Name

Having selected an 'Assignment' for the input, if required you can enter a name for the input in the 'Name' field.

Input Type

By selecting the 'Input Type' drop down menu you will be given the choice of 'Active Low' input will be **active** when **no voltage** (signal) is present or 'Active High' input will be **active** when a **voltage** (signal) is present.

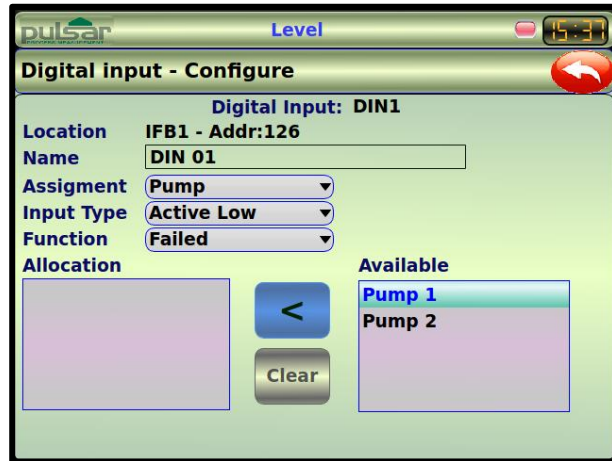

Function

Next you need to determine the **'Function'** that the digital input will respond to.

To select the **'Function'** you require, select it from the dropdown box under **'Function'**.

Full details of the **'Functions'**, and their descriptions, that are available, when the input **'Assignment'** is selected as **'Pump'**, are shown in the table opposite:

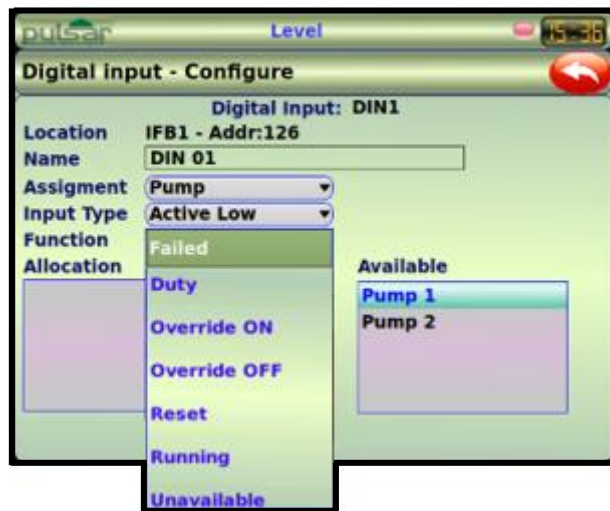

NAME	DESCRIPTION
Failed	If the Failed Input is present, the Ultimate Controller will indicate that the Pump is failed (Tripped/Out of Service depending on options set in the Auto Reset feature)
Duty	Input will provide a signal to manually select the lead device.
Override ON	Input will provide a signal to activate an Override ON condition of pumps as determined by Pump Advanced > Pump Override > Override Delay and Min. Override .
Override OFF	Input will provide a signal to activate an Override OFF condition of all selected pumps.
Reset	Input will provide a signal to reset all Device Fail signals.
Running	Input to identify that a pump is running. Also used for Smart Alarm signals
Unavailable	Input to identify that a pump is unavailable. Also used for Smart Alarm signals

Allocation

When 'Function' 'Failed', 'Duty', 'Override ON' or 'Override OFF' are selected you will be required to 'Allocate' the input to the device or devices that it is to be applied.

A list of available devices, as setup in Relays, will appear in the 'Available' box, to allocate a device to the input select it from the list in the 'Available' box and press  it will then be transferred to the 'Allocation' box confirming that it has been selected. If it is required to allocate more than one device to the same input, select the additional devices in turn and repeat the process above for each device.

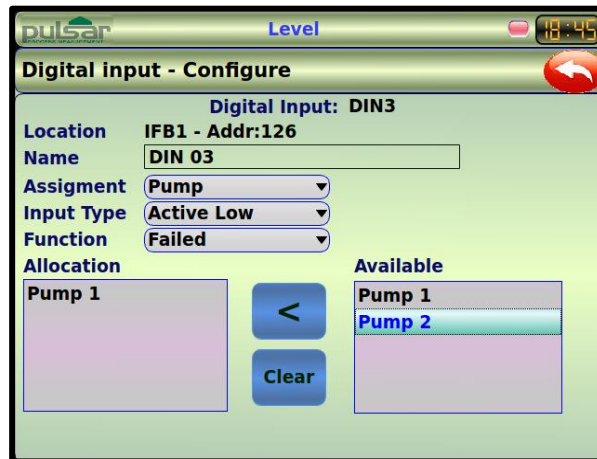

When the 'Function' 'Reset' has been selected you will not be asked to select an 'Allocation' as the reset will be applied to all devices.

To 'clear' an allocated device highlight it and press  and the device will be removed from the 'Allocation' box.

Backup

Having selected 'Backup' as the input 'Assignment' you will be presented with the screen detailed to the right.

You can now complete the setup of the input as follows.

Name

Having selected an 'Assignment' for the input, if required you can enter a name for the input in the 'Name' field.

Input Type

By selecting the 'Input Type' drop down menu you will be given the choice of 'Active Low' input will be active when no voltage (signal) is present or 'Active High' input will be active when a voltage (signal) is present.

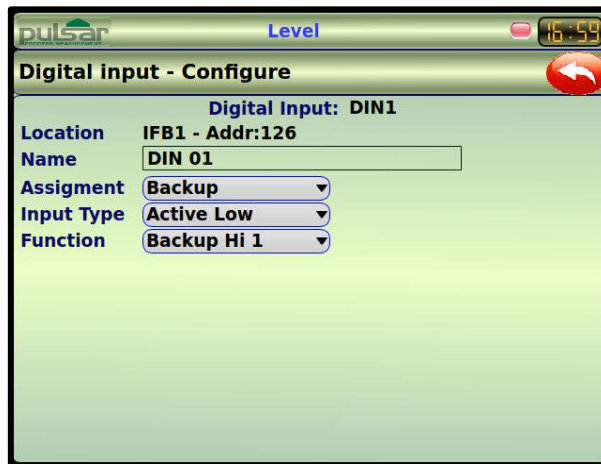

Function

Next you need to determine the 'Function' that the digital input will respond to.

To select the 'Function' you require, select it from the dropdown box under 'Function'.

Once the function has been setup you can change the pump and persist time of the input in 'Pump advanced > Backup Controls'.

Full details of the 'Functions', and their descriptions, that are available, when the input 'Assignment' is selected as 'Backup', are shown in the table below.

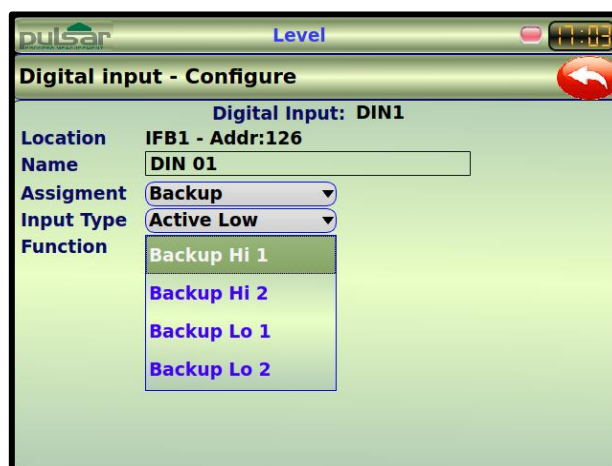

NAME	DESCRIPTION
Backup Hi 1	Backup device being used is Backup Hi 1
Backup Hi 2	Backup device being used is Backup Hi 2
Backup Lo 1	Backup device being used is Backup Lo 1

Maintenance

Having selected **'Maintenance'** as the input **'Assignment'** you will be presented with the screen detailed to the right.

You can now complete the setup of the input as follows.

Name

Having selected an **'Assignment'** for the input, if required you can enter a name for the input in the **'Name'** field.

Input Type

By selecting the **'Input Type'** drop down menu you will be given the choice of **'Active Low'** input will be **active** when **no voltage** (signal) is present or **'Active High'** input will be **active** when **a voltage** (signal) is present.

Function

Next you need to determine the **'Function'** that the digital input will respond to.

To select the **'Function'** you require, select it from the dropdown box under **'Function'**.

Full details of the **'Functions'**, and their descriptions, that are available, when the input **'Assignment'** is selected as **'Maintenance'**, are shown in the table opposite:

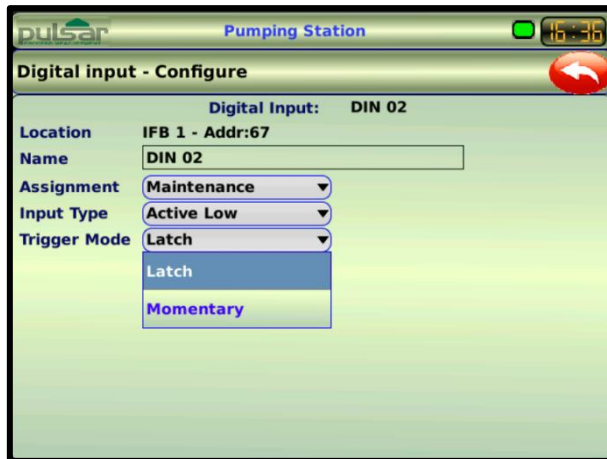
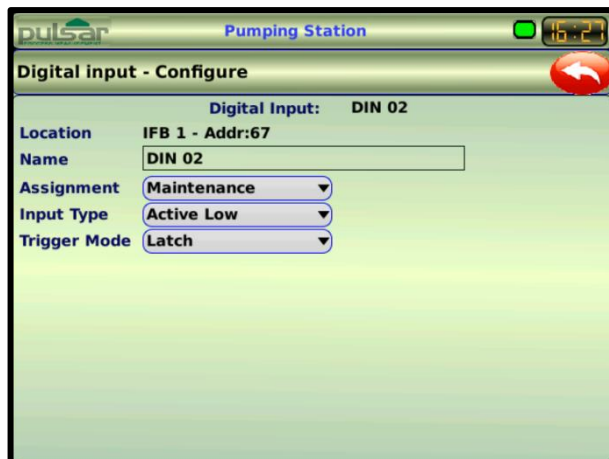

NAME	DESCRIPTION
Latch	Maintenance mode is active only while the digital input is active.
Momentary	Maintenance mode can be toggled on/off by momentary activation of the digital input. This mode enables the time out duration and alarm features (see Chapter 5.9 Maintenance for more information).

4.6 Sensors

On the main menu screen select

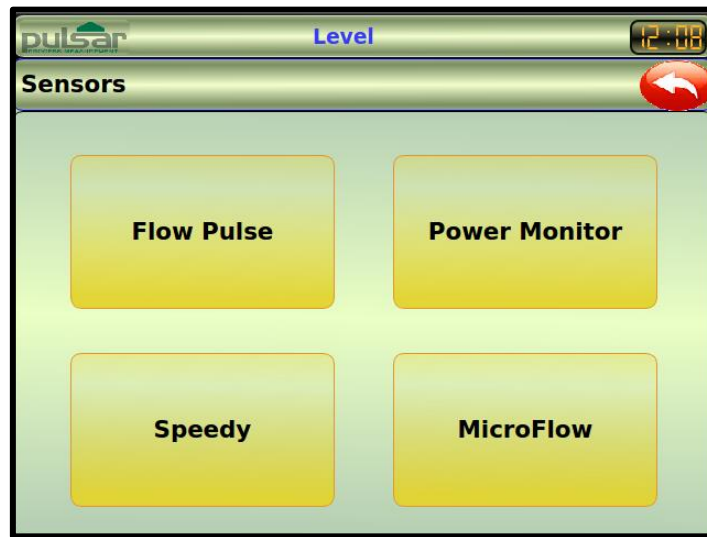
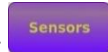

The sensors Menu provides configuration parameters for ancillary devices connected via the PBUS expansion port. Sensor configuration settings will only be accessible if the sensor has been registered as a Hardware Module from within the **Advanced Config. > Modules** menu. Once registered and configured, the sensors will be available in the **Application > Operation** menu to create measurement points to allow allocation to feature and outputs within Ultimate controller.

Flow Pulse

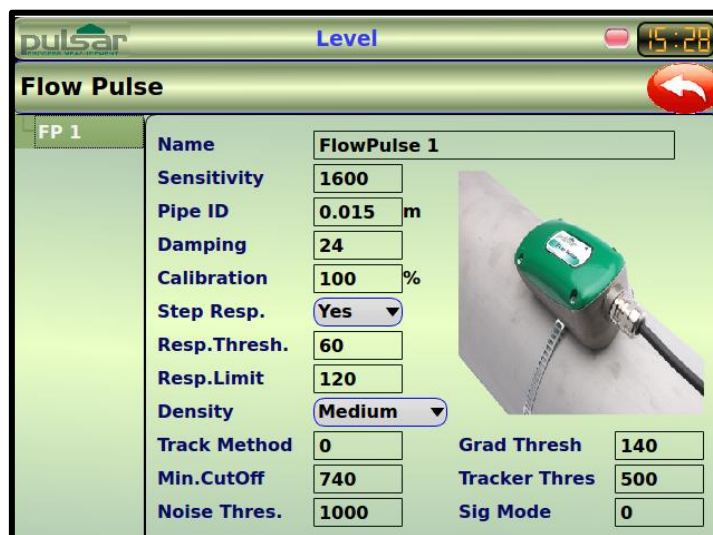

Flow Pulse is a non-intrusive in-pipe flow monitor with refracted spread spectrum analysis signal processing. Housed in a 316-cast stainless steel housing. Application parameters are: - flow velocity range 0.3 to 4m/s and having greater than 200 ppm particle concentration, pipe sizes 30mm OD and above. See separate Flow Pulse product manual for installation and operational guidelines. FlowPulse PC will be required to set the Modbus ID address of the unit from 126 (default value) to that of your choice. You will also need to change the baud rate (P53) to 57600 (option 6) for the FlowPulse to communicate with the Ultimate.

If multiple Flow Pulse devices have been registered as hardware modules, they will appear as additional choices in the tree list on the left-hand side of the Flow Pulse screen. For further information and installation details see separate manual supplied with unit.



OPTION	FUNCTION
Name	User definable name for the sensor
Sensitivity	Make more sensitive if the flow detection is not consistent or for low signal strengths (<60%). Make less sensitive to avoid spurious flow detection in noisy environments. Range: 800 (most sensitive) → 4000 (least sensitive). Default 1600
Pipe ID	Internal Diameter of Pipe entered in system measurement units. This allows the detected velocity to be translated to a flow rate.
Damping	Damping helps to smooth fluctuations from non-laminar flows. More damping will slow the measurement response time; less damping will speed up the measurement response time. Range: 10 (Less damping) → 40 (most damping). Default: 24
Calibration	Calibration factor in % to adjust the flow rate reported by flow pulse. Range: 0 -> 999 Default: 100%
Step Response <input type="button" value="Yes"/>	Step Response is a function which allows the damping to be bypassed if a large change in flow velocity is detected. This allows the Flow Pulse to respond quickly to pump start/stop events. YES , Step Response function is enabled (default) NO Step Response function is disabled
Resp. Thresh.	Response Threshold sets the instantaneous velocity change threshold required to trigger the Step Response function. Range: 40 → 400 Default: 60
Resp. Limit	Response Limit. When the Step Response function is activated, the Response limit sets the maximum amount the measurement will be allowed to change before re-evaluating the step response conditions. Range: 40 → 400 Default: 120
Density <input type="button" value="Medium"/>	Sets the Flow Pulse calibration for the particle density of the liquid being monitored. Options are Very Low, Low, Medium (Default), High, Very High
Track Method	Track Method adjusts the algorithm used by Flow Pulse to track the flow. This parameter should only be changed with Pulsar guidance.
Min. Cutoff	Minimum Flow Cut Off adjusts the threshold for the minimum detectable velocity. Reduce if flow detection is not consistent. May cause false flow detection if set too low. Range: 250 → 4000 Default: 740
Noise Thres.	Noise Threshold sets the amount of allowable noise to be present before the noise compensation algorithm activates. Range: 500 → 3000 Default:1000 This parameter should only be changed with Pulsar guidance.
Grad Thresh	Gradient Threshold Sets the trace gradient threshold for the tracking algorithm. Range:50 → 1000 Default: 140 This parameter should only be changed with Pulsar guidance.
Tracker Thres	Tracker Threshold Sets the magnitude threshold for the tracking algorithm. Range:200 → 5000 Default: 500 This parameter should only be changed with Pulsar guidance.
Sig Mode	Signal Mode sets the mode used for calculating the signal strength. This parameter should only be changed with Pulsar guidance.

Flow Pulse Diagnostic traces

When a flow Pulse device has been registered as a Hardware module, a Flow Pulse symbol  will be visible on the main Run Mode screen. Touching  will show the Flow Pulse diagnostic trace screen.

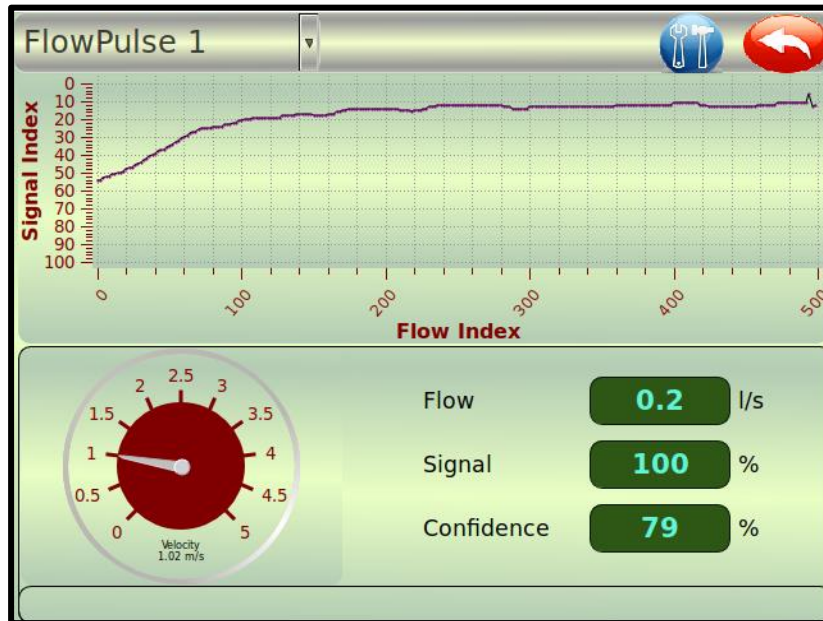

The screen provides a graph of Signal Index against Flow Index, and an analogue velocity indicator. Values of Flow Rate, Signal Strength, and Signal Confidence are also given for diagnostic purposes. All the trace and diagnostic data on the screen gets refreshed on a regular cyclic basis.

CONTROL	FUNCTION
FlowPulse 1	Selects which Flow Pulse device to view the diagnostic data.
	Allows access to echo algorithm adjustment parameters via a service passcode.
Flow	Reported Flow Rate
Signal	Flow Signal Strength
Confidence	Confidence in reported flow reading

Multiple devices

When using the FlowPulse sensor, please use the FlowPulse manual for specifics on how and where to setup a FlowPulse. The extreme ends of the Modbus cabling should be terminated with a 120R resistor (this is achieved in FlowPulse via the termination switch).

Wiring details:

DESCRIPTION	ULTIMATE TERMINAL NO.	FLOWPULSE TERMINAL NO.
24V DC (power)	5	1
0V	6	2
RS485 +	7	9
RS485 -	8	10
RS485 Com (Screen)	9	8

If you are using multiple FlowPulse units an example of how to wire these units to the Ultimate controller is shown below:

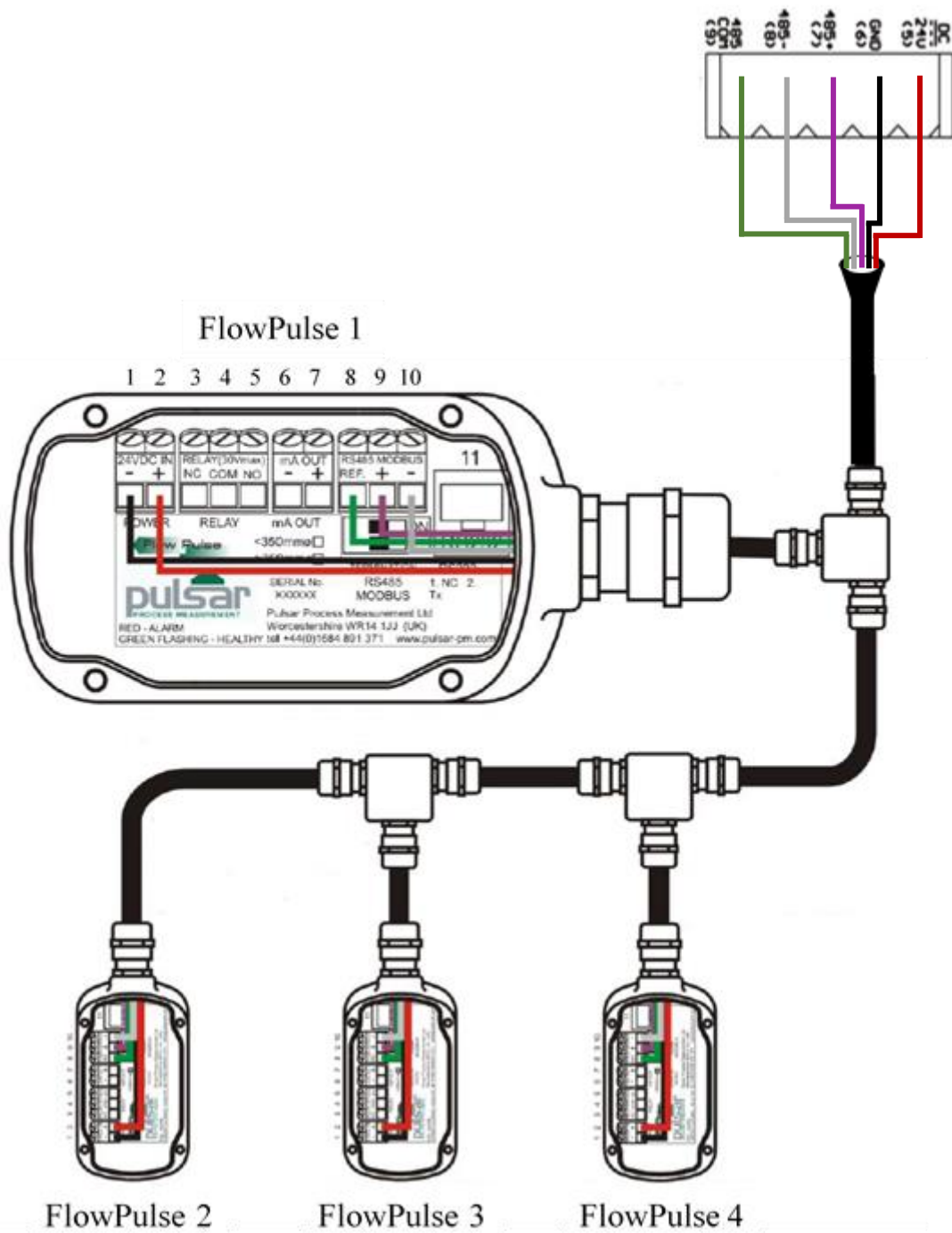

Important Information

The above colouring of cabling may vary from that used for installation, the diagram above is for illustration purposes only. A screened multi-core cable should be used for connecting the units to the Ultimate (minimum conductor size of 0.5mm²). For further details on installation information, please refer to the FlowPulse user manual.

Speedy

The Speedy is a velocity sensor designed to measure the velocity in all open channels and pipes of any shape or size. Combined with channel dimensions and a separate level measurement, the Speedy is used to provide an Open Channel Flow measurement using the Area*Velocity method.

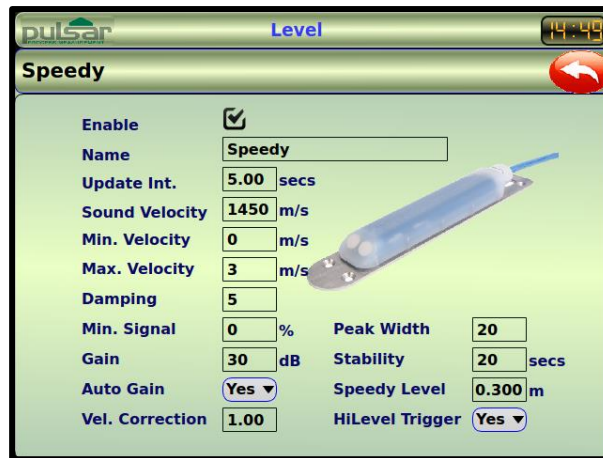

OPTION	FUNCTION
Name	User definable name for the sensor
Update Int.	Update Interval sets the update or polling interval, at which the Ultimate will obtain an updated velocity reading from the Speedy sensor. Range: 0 → 120 Default:5 (Seconds)
Sound Velocity	Sound Velocity sets the initial value for the velocity of sound in water. Range: 0 → 99999 Default: 1450 (m/s)
Min. Velocity	Sets the minimum value for flow velocity, below which, flow values will be ignored. Range: -6 → 6 Default 0 (m/s)
Max. Velocity	Sets the maximum value for flow velocity, above which, flow values will be ignored. Range: -6 → 6 Default 3 (m/s)
Damping	Damping Factor sets the value of damping applied to the speedy velocity measurement. Range: 5 → 155 Default: 5 (Seconds)
Min Signal	Minimum signal Quality defines the signal quality threshold below which readings will be discarded. Range 0 → 100 Default: 0 (%)
Gain	Sets the fixed amount of gain used for the measurement if the Auto Gain feature is not enabled. Range: 0 → 550 Default: 55
Auto Gain <input type="button" value="Yes"/>	Enables/Disables the Auto Gain feature
Vel. Correction	Velocity correction allows the reported velocity value to be factored to compensate for non-laminar flows. Range: 0 → 4 Default: 1
Peak Width	Sets the evaluation width in percentage, the Speedy locates the frequency at each histogram evaluation which contains the most edge measurements within a frequency window defined by the peak width. Range:0 → 100 Default:20 (%)
Stability	Sets the time, in seconds, of how long the latest valid measurement will be held. Range: 0 → 255 Default: 20 (Seconds)
Speedy Level	Sets the initial value for the head of water above the Speedy, this value is only used when the Speedy is initialised and is used for the first few readings. Range:0 → 99 Default: 0.3 (Metres)
Hi Level Trigger <input type="button" value="Yes"/>	This parameter can be used to set the sensitivity of the Speedy velocity sensor. Yes = Recommended Trigger setting (Default) No = Most sensitive, but more susceptible to interference

Prior to setting up your application, the speedy device will need to be enabled to allow communication with the Ultimate. Please refer to 'Chapter 5.4 Communication > RS232/RS485 Setup' for further information on how to do this.

Important Information
 Only one speedy device can be connected to the Ultimate Controller at any time.

Power Monitor

The Pulsar Power Monitor module is designed to be used with single, or three phase systems. One power monitor unit is required per electrical device to be monitored. See separate Power Monitor product manual for installation and operational guidelines. The Modbus ID address of the unit will appear on a label next to the RS485 terminals. If multiple Power Monitor devices have been registered as hardware modules, they will appear as additional choices in the tree list on the left-hand side of the Power Monitor screen.

For further information and installation details see separate manual supplied with unit.

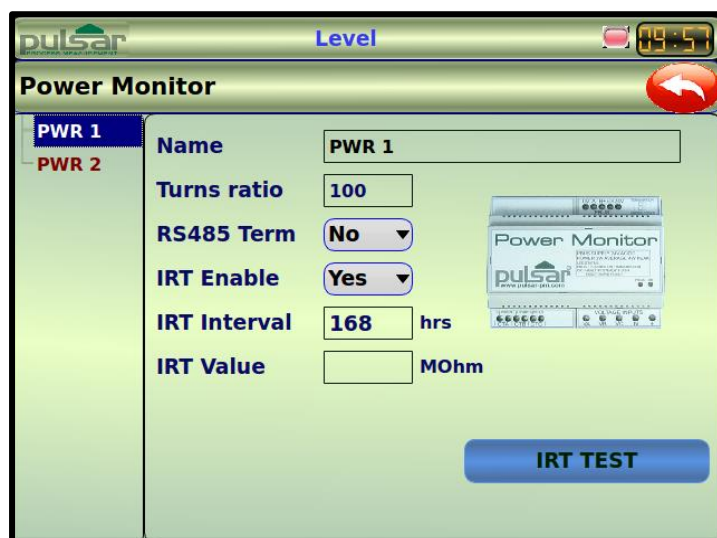

PARAMETER	FUNCTION
Name	User definable name for the sensor
Turns Ratio	Sets the Turns Ratio of the Current Transformers being used with the Power monitor. Range: 0 → 9999 Default: 100
RS485 Term <input type="button" value="No"/>	Active RS485 Termination If the Power Monitor is the last device on the PBUS expansion bus, the active termination should be enabled. No = Termination disabled Yes = Termination enabled You will also need to physically switch the active termination on the device at the end of the PBUS.
IRT Enable <input type="button" value="Yes"/>	Enables/Disables the Insulation Resistance Test function.
IRT Interval	If IRT is enabled, the IRT Interval specifies the time interval between automatic IRT tests. Range: 0 → 99999 Default: 168 (Hours)
IRT Value	Displays the result of the most recent IRT test (MOhms)
IRT Test <input type="button" value="IRT TEST"/>	Initiates an immediate IRT test.

Multiple devices

When using the Power Monitor, refer to the user manual for specifics on how to setup the device. The extreme ends of the Modbus cabling should be terminated with a 120R resistor (this is achieved on the Power Monitor via the termination switch). Wiring details:

DESCRIPTION	ULTIMATE TERMINAL NO.	POWER MONITOR TERMINAL NO.
24V DC (power)	5	16
0V	6	15
RS485 +	7	14
RS485 -	8	13
RS485 Com (Screen)	9	12

If you are using multiple Power Monitor units an example of how to wire these units to the Ultimate controller is shown below:

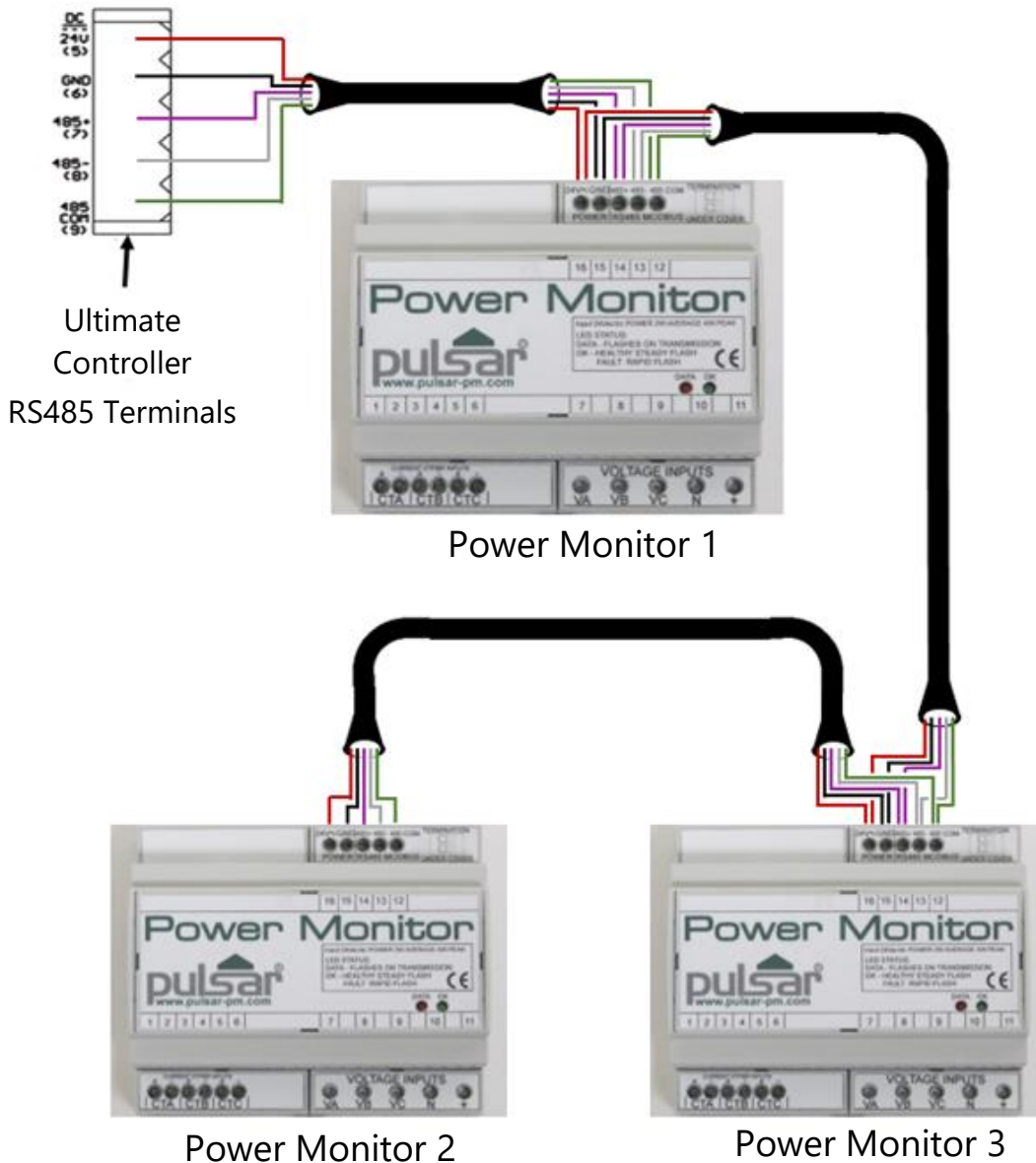

Important Information

The above colouring of cabling may vary from that used for installation, the diagram above is for illustration purposes only. A 4-core or 2 x twisted pair overall screened cable should be used for connecting the units to the Ultimate (minimum conductor size of 0.5mm²). For further details on installation information, please refer to the Power Monitor user manual.

MicroFlow

The MicroFlow is a non-contacting velocity sensor, providing reliable flow velocity measurements in all open channels. Combined with channel dimensions and a separate level measurement, it is used to provide an Open Channel Flow measurement using the Area*Velocity method. MicroFlow PC will be required to set the Modbus ID address of the unit from 126 (default value) to that of your choice. If multiple MicroFlow sensors have been registered as hardware modules, they will appear as additional choices in the tree list on the left-hand side of the MicroFlow screen. Further information can be found in the separate MicroFlow manual.

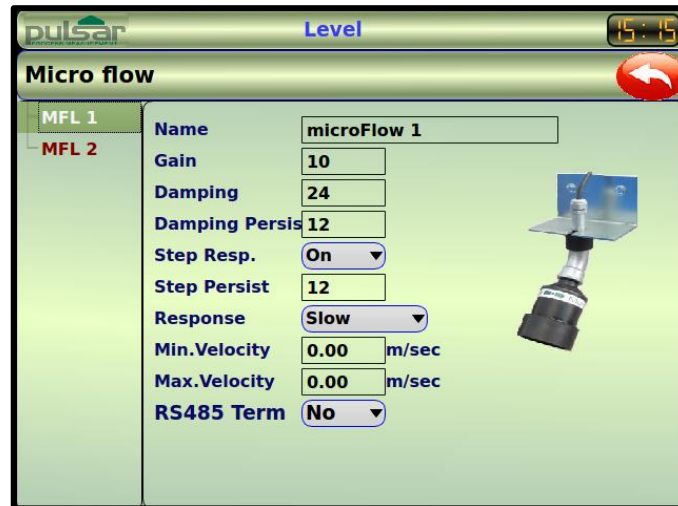

OPTION	FUNCTION
Name	User definable name for the sensor
Gain	Sets the fixed amount of gain (sensitivity) used for the measurement. A higher number means a higher amount of gain applied. Range: 1 → 16 Default = 10
Damping	This sets the value of damping applied to the MicroFlow sensor's velocity measurement. A higher number represents more damping. Range: 0 → 28 Default = 24
Damp Persist	This is the number of measurements that the sensor acquires, before switching into Step Response Mode. Range: 0 → 18 Default = 12
Step Response Mode <input type="button" value="On"/>	Off → When turned off, no damping bypass will be performed. Default = On → when turned on, damping bypass is activated.
Step Persist	This is the number of measurements that the sensor acquires, before switching into damping mode. Range: 0 → 18 Default = 12
Response <input type="button" value="Slow"/>	Sets the speed to track velocity measurements. Fast → This will automatically calibrate parameters in the MicroFlow sensor to track measurements faster. This is recommended for Pumped flow. Default = Slow → This is recommended when there is natural flow, as measurements will be tracked at a slower pace.
Min. Velocity	Sets the minimum value for flow velocity, below which, flow values will be ignored. Range: 0 → 6 Default 0 (m/s)
Max. Velocity	Sets the maximum value for flow velocity, above which, flow values will be ignored. Range: 0 → 6 Default 0 (m/s)
RS485 terminations <input type="button" value="No"/>	Active RS485 Termination If the MicroFlow is the last device on the PBUS expansion bus, the active termination should be enabled. No = Termination disabled Yes = Termination enabled

MicroFlow diagnostic traces

When a MicroFlow has been registered as a Hardware module and is used with an OCM application, the MicroFlow symbol will appear on the main display above the PMD displayed on the screen. Pressing this symbol will display the MicroFlow diagnostic trace for each sensor as shown below:

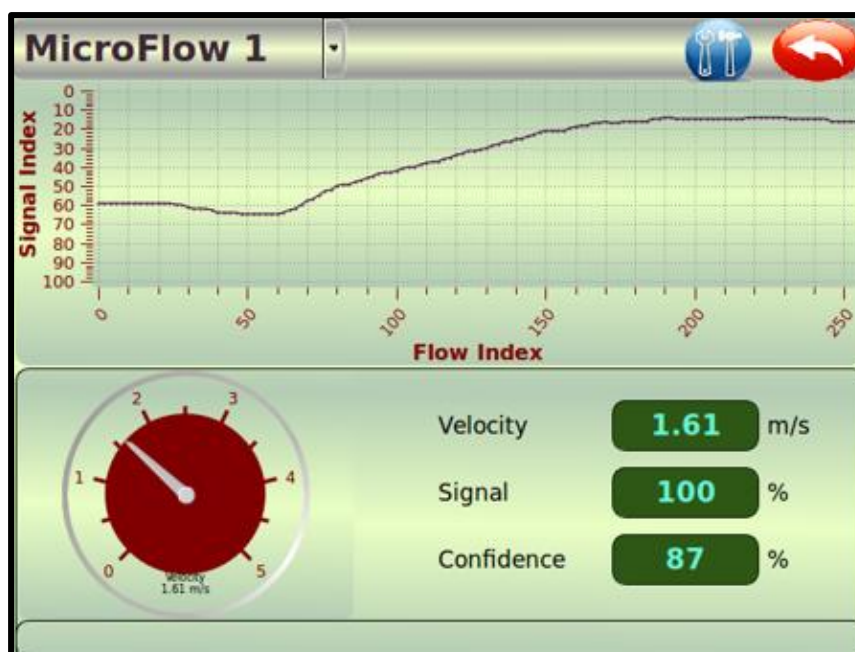

This screen provides a graph of the signal index against the flow index, and an analogue velocity indicator. Values of the current velocity rate, Signal Strength and Signal Confidence are also displayed for diagnostic purposes. All of the trace and diagnostic data displayed on the screen gets refreshed on a regular cyclic basis.

CONTROL	FUNCTION
MicroFlow 1	Selects which MicroFlow device to view the diagnostic data from.
	Allows you to choose between the MicroFlow sensors setup and view their individual diagnostic traces.
	Allows access to algorithm adjustment parameters in the sensor.
Velocity	Reported velocity rate from the MicroFlow sensor.
Signal	Flow Signal Strength
Confidence	Confidence in the reported flow strength.

Multiple devices

When using the MicroFlow sensor, please refer to the MicroFlow manual for specifics on how and where to setup a MicroFlow. The end sensor of the Modbus 'loop' should be terminated. This is achieved by changing the RS485 terminations selection from 'No' to 'Yes' on the MicroFlow setup screen in **Sensors**.

DESCRIPTION	ULTIMATE TERMINAL NO.
24V DC (power)	5
0V	6
RS485 +	7
RS485 -	8
RS485 Com (Screen)	9

If you are using multiple MicroFlow units, an example of how to wire these units to the Ultimate controller is shown below:

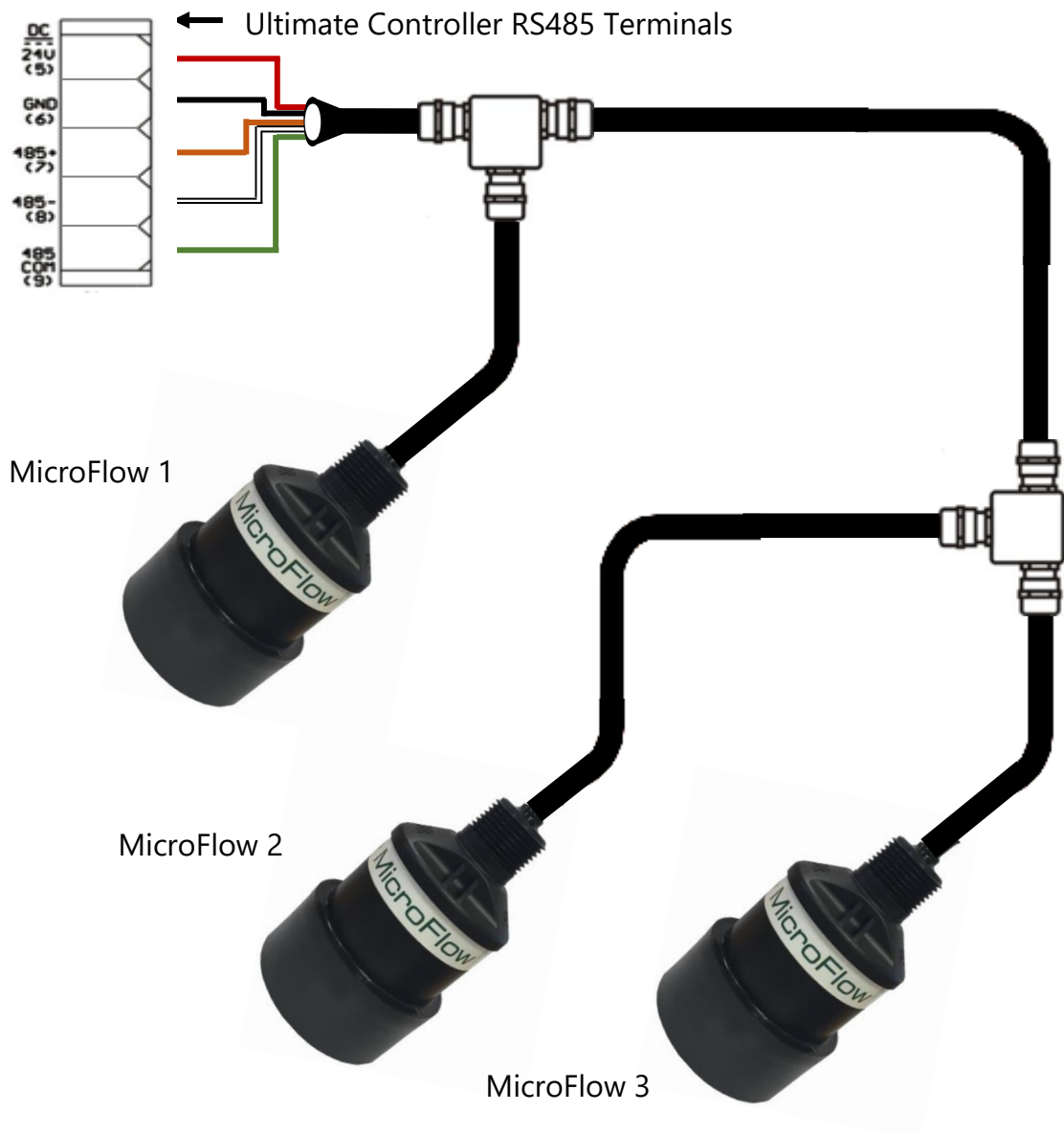

Important Information

The above colouring of cabling may vary from that used for installation, the diagram above is for illustration purposes only. A screened multi-core cable should be used for connecting the MicroFlow(s) to the Ultimate (minimum conductor size of 0.5mm²). For further details on installation information, please refer to the MicroFlow user manual.

4.7 Volume

On the Main Menu screen select

Volume

This feature enables volume conversion to be applied to a Level measurement point by the setting up of a **volume profile** which is applied to the selected **point of measurement**. Each profile allows for a variety of volume calculation features with **11** pre-programmed **vessel shapes**. For each profile, you will need to know the **vessel dimensions** in **Measurement Units** which are required to calculate the **volume** which will be displayed in the selected **Volume Units**.

If your vessel shape does not correspond with any of the pre-programmed vessel shapes, then you can use the **universal calculations**. For this you will need a level/volume graph or chart provided by the vessel manufacturer or you can create one based on the dimensions of the vessel. You can enter up to 32 pairs of breakpoints, and the more you enter, the greater accuracy of the volume calculation will be.

On completing the setup of a **volume profile**, the **Display** and **mA Outputs** can be assigned to the **Volume profile** from their respective menus, so the reading can be displayed in run mode and on how the mA output will react.

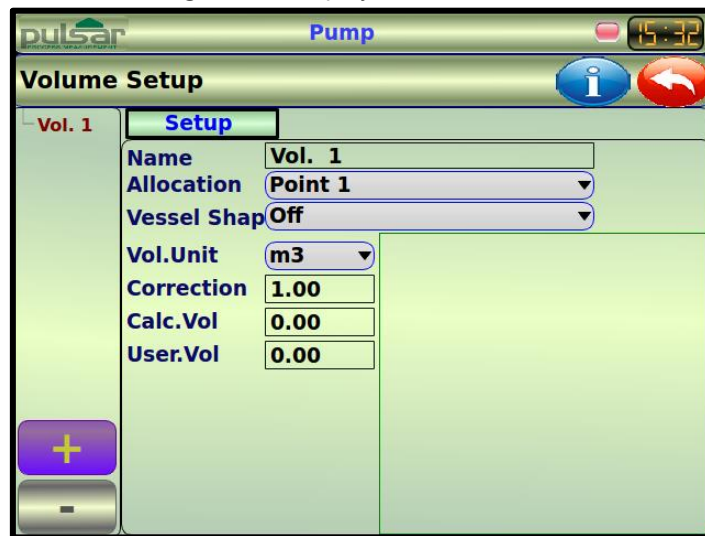

All current **volume profiles** will be listed by their given names in the tree list on the left-hand side of the screen. Swap between the profiles by selecting a name on the tree list. New profiles can be added or, when selected, existing ones deleted.

Setup

Name

If required, each individual **volume profile** can be given a specific name to suit the process or application and will be used to identify the profile in any subsequent display or menu allocation.

Allocation

Selects the Level measurement point to which the Volume Profile will be applied.

Vessel Shape

Determines which vessel shape is used when setting up a **volume profile**.

The choices are as shown in the table below, along with the **dimensions** that are required to be entered.

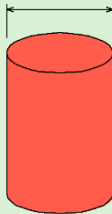
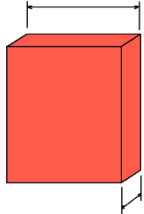
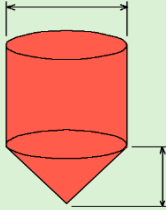
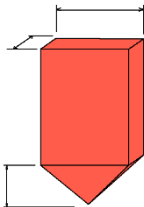

DESCRIPTION	VESSEL SHAPE	DIMENSIONS
Cylindrical Flat Base		Cylinder Diameter
Rectangular Flat Based		Width and Breadth
Cylindrical Conical Base		Cylinder Diameter and Height of Cone
Rectangular Pyramid Base		Width and Breadth of Rectangular section and Height of Pyramid base.

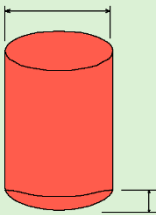
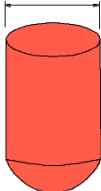
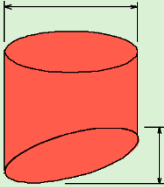
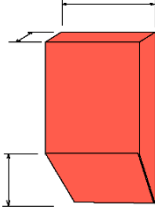
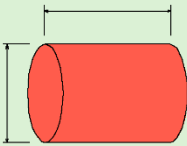
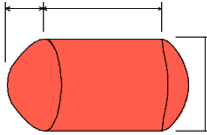
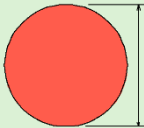
DESCRIPTION	VESSEL SHAPE	DIMENSIONS
Cylindrical Parabolic Base		Cylinder Diameter and Height of Parabolic bottom
Cylindrical Hemi-Spherical		Cylinder Diameter
Cylindrical Sloped Base		Cylinder Diameter and Height of Sloped bottom
Rectangular Sloped Base		Width and Breadth of Rectangular section and Height of Sloped bottom
Cylindrical Flat Ends		Cylinder Diameter and Tank Length
Cylindrical Parabolic Ends		Cylinder Diameter, Length of one Parabolic end section and Tank Length
Sphere		Sphere Diameter

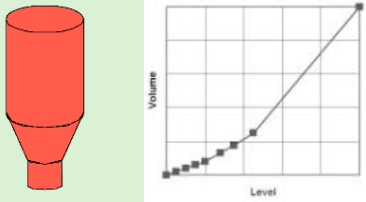
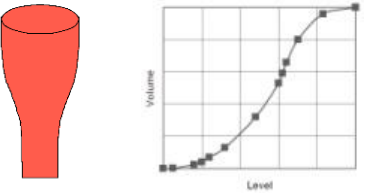
DESCRIPTION	VESSEL SHAPE	DIMENSIONS
Universal Linear		No dimensions required, level and volume breakpoints used.
Universal Curved		No dimensions required, level and volume breakpoints used.

Dimensions

Once you have selected the **vessel shape** select each **dimension**, in turn, and enter the appropriate value in **measurement units**.

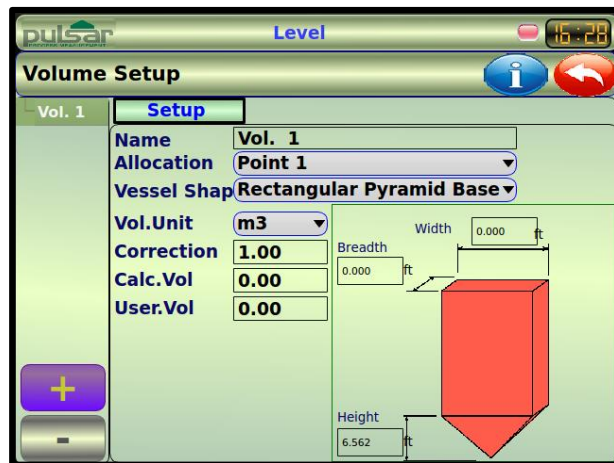

Volume Units

Determines the units used to calculate and display the resultant volume conversion.

The choices of units are detailed in the table below.

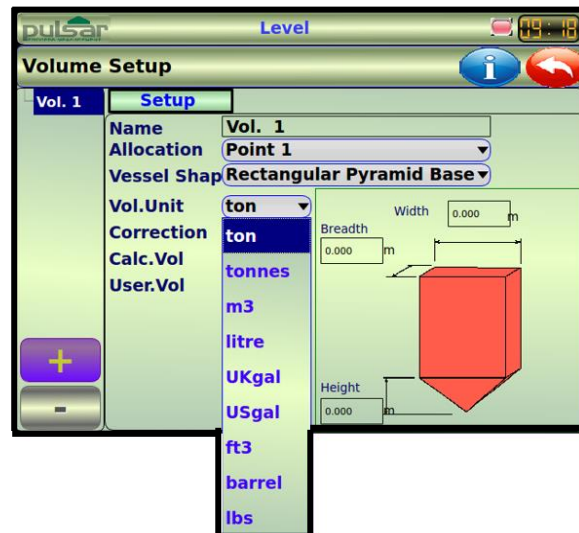

OPTION	DESCRIPTION
Ton	Volume will be calculated and displayed in Tons
Tonne	Volume will be calculated and displayed in Tonnes
Cubic metres (M ³)	Volume will be calculated and displayed in Cubic metres (M³)
Litres	Volume will be calculated and displayed in Litres
UK Gallons	Volume will be calculated and displayed in UK Gallons (UKgal)
US Gallons	Volume will be calculated and displayed in US Gallons (USgal)
Cubic Feet (ft ³)	Volume will be calculated and displayed in Cubic Feet (ft³)
Barrels	Volume will be calculated and displayed in Barrels
Pounds (lbs.)	Volume will be calculated and displayed in Pounds (lbs.)

Correction

This option is used to enter a correction factor, when required, such as the specific gravity of the material so that the volume calculated is relative to the actual amount of material that can be contained between **empty level** (zero) and 100% of **span** (full).

Calc. Vol

Displays the value of the maximum volume that has been calculated from the span and vessel dimensions, this value is for information only and cannot be changed. The volume displayed will be shown in the **volume units** selected and is the **total volume** available between **empty level** (zero) and 100% of **span** (full).

User Vol

Displays the actual maximum volume after any correction factor has been applied, **Calc. Vol x Correction**, but can be **overwritten** if required to allow entry of a **user calculated volume**, if overwritten the **correction value** will be **changed** to reflect the user volume entered. The volume displayed will be shown in **volume units** and is the total **corrected volume** available between **empty level** (zero) and 100% of **span** (full).

Breakpoints

Level/Volume Breakpoints

Breakpoints are used to create a profile of the vessel when the **Vessel Shape** selected is either **Universal Linear** or **Universal Curved**. You should enter breakpoints in pairs, a reading for level and its corresponding volume. The more pairs you enter, the more accurate the profile will be. In the case of universal linear, then enter the level/volume at each of the points where the vessel changes shape. In the case of the universal curved, enter values around each arc tangent, as well as at the top and bottom.

To enter a breakpoint, select the relevant box and enter the required value via the popup keypad. You must enter at least two pairs, with the **first pair** always being **zero**, and you can enter up to 32 pairs.

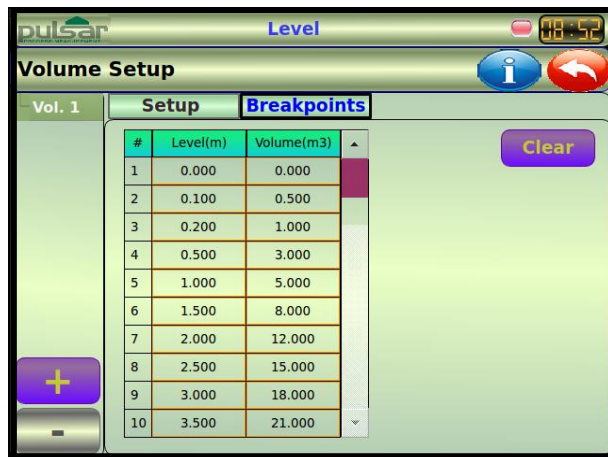

Universal Linear

This volume calculation creates a linear approximation of the level/volume relationship and works best if the vessel has sharp angles between each section.

You should enter a level/volume breakpoint for each place where the vessel changes direction, and a number of breakpoints where the section is slightly curved (mostly linear but has got a small arc). You can enter any number of pairs between 2 and 32.

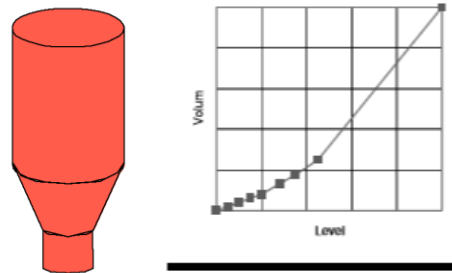

Universal Curved

This volume calculation creates a curved approximation of the level/volume relationship, and works best if the vessel is non-linear, and there are no sharp angles.

You should enter 2 level/volume breakpoints at the minimum and maximum levels, and several for each place where the vessel has got an arc. You can enter any number of pairs between 2 and 32.

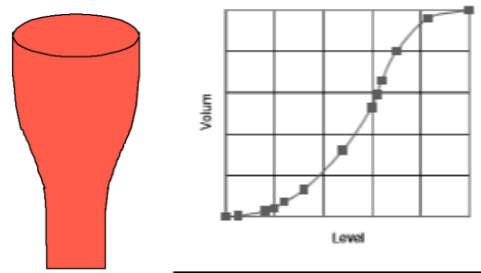

Clear

Selecting the **Clear** button will clear **all breakpoints** that have been set, to change an individual setpoints value simply select the setpoint box and use the pop-up keypad to reset it to its default value or enter a new value.

Information 

When you have completed setting up a volume profile using either one of the 11 pre-programmed vessel shapes or a universal calculation, by selecting the  button the table shown to the right will appear giving details details of the calculated volume at 0.1 meter increments from zero (empty) to 100% of span (full).

L(ft)	Vol(m3)	L(ft)	Vol(m3)	L(ft)	Vol(m3)
0.000	0.000	4.331	5.280	8.661	10.560
0.217	0.264	4.547	5.544	8.878	10.824
0.433	0.528	4.764	5.808	9.094	11.088
0.650	0.792	4.980	6.072	9.311	11.352
0.866	1.056	5.197	6.336	9.528	11.616
1.083	1.320	5.413	6.600	9.744	11.880
1.299	1.584	5.630	6.864	9.961	12.144
1.516	1.848	5.846	7.128	10.177	12.408
1.732	2.112	6.063	7.392	10.394	12.672
1.949	2.376	6.280	7.656	10.610	12.936
2.165	2.640	6.496	7.920	10.827	13.200
2.382	2.904	6.713	8.184	11.043	13.464
2.598	3.168	6.929	8.448	11.260	13.728
2.815	3.432	7.146	8.712	11.476	13.992
3.031	3.696	7.362	8.976	11.693	14.256
3.248	3.960	7.579	9.240	11.909	14.520
3.465	4.224	7.795	9.504	12.126	14.784
3.681	4.488	8.012	9.768	12.139	14.800
3.898	4.752	8.228	10.032		
4.114	5.016	8.445	10.296		

TOUCH SCREEN TO CLOSE

Important Information
 Ensure that you use the Display and mA output menus to allocate the volume profile as required.

4.8 OCM App. (Open Channel Measurement Application)

On the Main Menu screen select .

This feature enables flow applications to be applied to a point of measurement by setting up a **OCM application**. Each profile allows for a wide variety of OCM calculations, with **31** pre-programmed **channel shapes**. For each of the profiles you will need to know the **channel dimensions** in **Measurement units** which are required to calculate the **maximum flow** at the **maximum head**.

This feature also enables you to setup general totalisers for any Flow or OCM App. Measurement point that has been setup. Please refer to **Chapter 4.2 Application Setup** for information on how to do this.

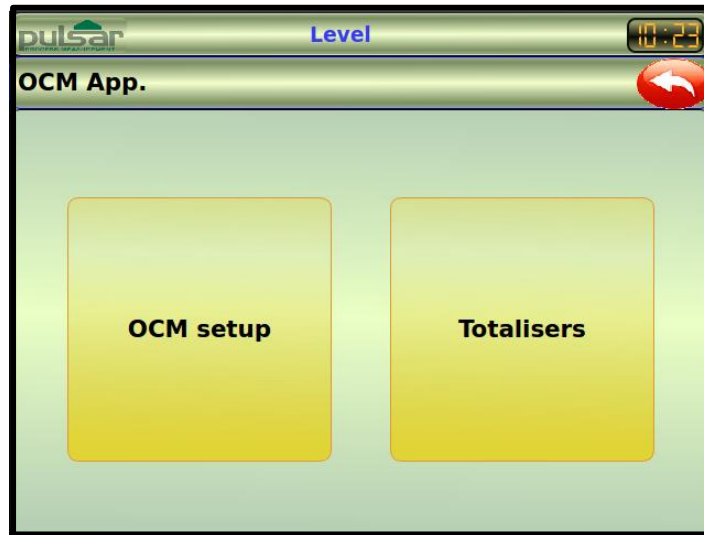

OCM Setup

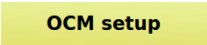
Selecting  will allow you to setup your OCM application using the options on the screen.

If your Primary Measuring Device (PMD) does not match any of the devices contained in the pre-programmed PMD types, then a **universal calculation** can be performed. When selected, the **Breakpoints** screen will become available, and a head versus flow table is used to enter a set of breakpoints for head and flowrate.

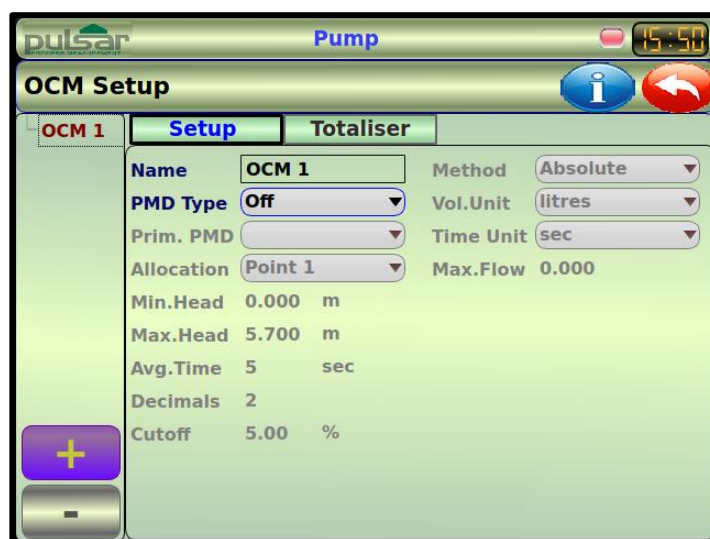

All current **OCM profiles** will be listed by their given names in the tree list on the left-hand side of the screen. Swap between the profiles by selecting a name on the tree list. New profiles can be added or, when selected, existing ones deleted.

Setup

Name

If required, each individual **OCM profile** can be given a specific name to suit the process or application and will be used to identify the profile in any subsequent display or menu allocation.

PMD type

This determines the type of PMD (Primary Measuring Device).

The choices are as shown in the picture opposite.



Primary Measuring Device

When a PMD type has been chosen, you can now choose from a selection 6 flow applications: **Exponent**, **BS3680 Flume**, **BS3680 Weir**, **Area Velocity**, **Special** and **Universal**.

Exponent

When the PMD is a simple exponential device, you are able select from the drop-down menu the application you are setting up. When a selection is made the controller will illustrate an image of that particular device, and where applicable you will be required to enter a dimension in **measurement units** on that image, so the **Max Flow** calculation can be performed correctly.

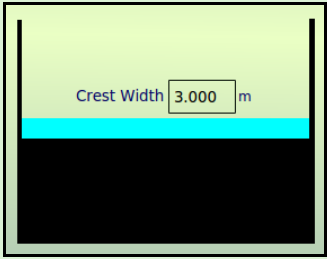
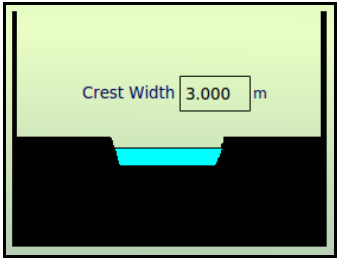
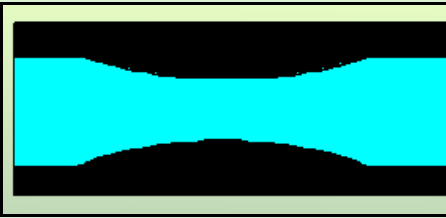
EXPONENTIAL DEVICE	DIAGRAM	DIMENSIONS REQUIRED
Rectangular Weir (Without end contractions)		Dimension A (Crest Width)
Trapezoidal (Cipolletti) Weir		Dimension A (Crest Width)
Venturi Flume		Not required

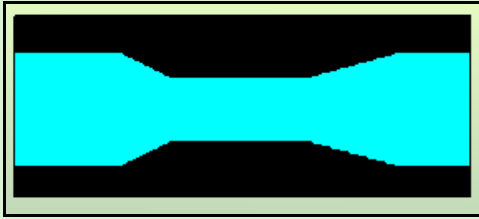
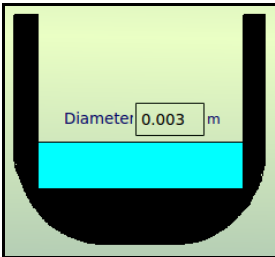
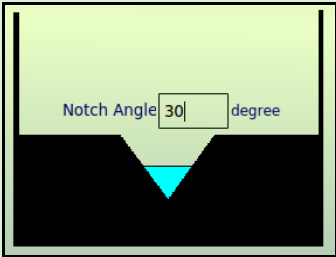
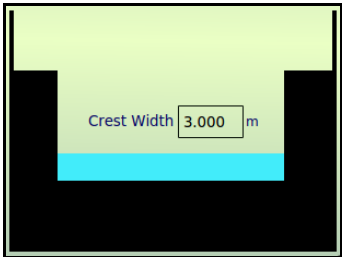
EXPONENTIAL DEVICE	DIAGRAM	DIMENSIONS REQUIRED
Parshall Flume		Select Throat Width: 1 inch 2 inches 3 inches 6 inches 9 inches 12 inches 18 inches 2 feet 3 feet 4 feet 5 feet 6 feet 7 feet 8 feet 10 feet 12 feet 15 feet 20 feet 25 feet 30 feet 40 feet 50 feet
Leopold Lagco Flume		Dimension A (Diameter)
V-Notch Weir		Dimension A (V-Notch angle)
Contracted Rectangular Weir (With end contractions)		Dimension A (Crest Width)

Exponent Calculations

If the flow calculation is to be **Absolute** the flow will be calculated using the formula(s) as follows:

EXPONENTIAL DEVICE	FORMULA	EXPONENT	K FACTOR
Rectangular Weir (Without end contractions)	$Q = K L h^x$ Where: Q = Flowrate K = K Factor L = Crest Width h = Head x = Exponent	(1.50) Automatically set by the Ultimate	Automatically calculated by the Ultimate
Trapezoidal (Cipolletti) Weir	$Q = K L h^x$ Where: Q = Flowrate K = K Factor L = Crest Width h = Head x = Exponent	(1.50) Automatically set by the Ultimate	Automatically calculated by the Ultimate
Venturi Flume	$Q = K h^x$ Where: Q = Flowrate K = K factor h = Head x = Exponent	(1.50) Automatically set by the Ultimate	Enter a value as required in the K Factor parameter box.
Parshall Flume	$Q = K h^x$ Where: Q = Flowrate K = K factor h = Head x = Exponent	Automatically set by the Ultimate	Automatically calculated by the Ultimate
Leopold Lagco Flume	$Q = K D^{0.0953} h^x$ Where: Q = Flowrate K = K Factor D = Diameter h = Head x = Exponent	(1.55) Automatically set by the Ultimate	Automatically calculated by the Ultimate
V-Notch Weir	$Q = K h^x$ Where: Q = Flowrate K = K Factor h = Head x = Exponent	(2.50) Automatically set by the Ultimate	Automatically calculated by the Ultimate.
Other	$Q = K h^x$ Where: Q = Flowrate K = K Factor h = Head x = Exponent	Enter a value as required in the Exponent parameter box	Enter a value as required in the K Factor parameter box.
Contracted Rectangular Weir (With end contractions)	$Q = K(L-0.2*h)h^x$ Where: Q = Flowrate K = K Factor L = Crest Width h = Head x = Exponent	(1.50) Automatically set by the Ultimate	Automatically calculated by the Ultimate.

If the flow calculation is to be **Ratiometric**, the flow will be calculated using the formula: $Q = Q_{cal} (H/H_{cal})^x$

- Where: Q = Flowrate
 Q_{cal} = Flowrate at **maximum head**.
 h = Head
 h_{cal} = **Maximum head**
 x = Exponent (determined as in Absolute calculation)

BS3680 Flume

When the PMD is a **BS3680 Flume** device, you are able to select from the drop-down menu the application you are setting up. You will be required to enter dimensions in **measurement units** on that image, so the **Max Flow** calculated can be performed correctly.

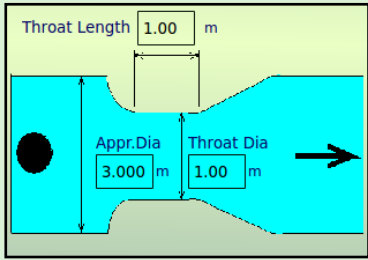
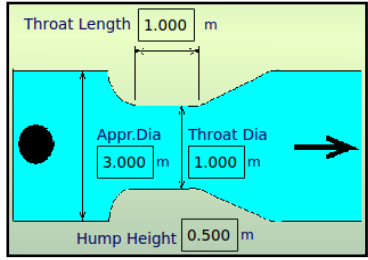
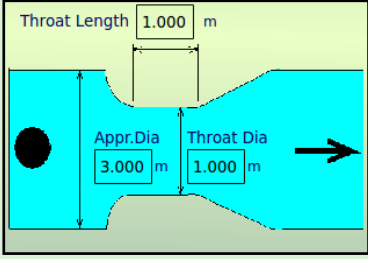
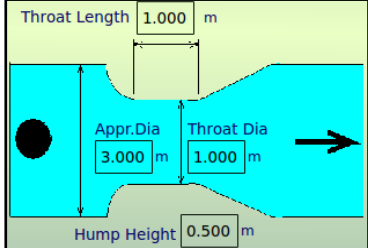
BS3680 FLUME	DIAGRAM	DIMENSIONS REQUIRED
<p>Rectangular Flume</p>		<p>Dimension A (Approach Width) Dimension B (Throat Diameter) Dimension C (Throat Length)</p>
<p>Rectangular Flume with Hump</p>		<p>Dimension A (Approach Width) Dimension B (Throat Diameter) Dimension C (Throat Length) Dimension D (Hump Height)</p>
<p>U-Throated Flume</p>		<p>Dimension A (Approach Width) Dimension B (Throat Diameter) Dimension C (Throat Length)</p>
<p>U-Throated Flume with Hump</p>		<p>Dimension A (Approach Width) Dimension B (Throat Diameter) Dimension C (Throat Length) Dimension D (Hump Height)</p>

BS3680 Flume Calculations

If the flow calculation is to be **Absolute** or **Ratiometric**, the flow will be calculated using the formula's as follows:

BS3680 FLUME	ABSOLUTE FORMULA	RATIOMETRIC FORMULA
Rectangular Flume	$Q = (2/3)^{1.5} gn^{0.5} C_s C_v C_d b h^{1.5}$ Where: Q = Flowrate gn = gravitational acceleration (nominal value of = 980.66cm/s ²) C _s = Shape coefficient (value = 1) C _v = Velocity coefficient (Calculated by the Ultimate) C _d = Discharge coefficient (Calculated by the Ultimate) b = Approach width h = Head from bottom of channel	$Q = Q_{cal} (C_v/C_{vcal}) (C_d/C_{dcal}) (h/h_{cal})^{1.5}$ Where: Q = Flowrate C _v = Velocity coefficient (Calculated by the Ultimate) C _{vcal} = Velocity coefficient at maximum head C _d = Discharge coefficient (Calculated by the Ultimate) C _{dcal} = Discharge coefficient at maximum head h = Head h _{cal} = Maximum head
Rectangular Flume with Hump	$Q = (2/3)^{1.5} gn^{0.5} C_s C_v C_d b h^{1.5}$ Where: Q = Flowrate gn = gravitational acceleration (nominal value of = 980.66cm/s ²) C _s = Shape coefficient (value = 1) C _v = Velocity coefficient (Calculated by the Ultimate) C _d = Discharge coefficient (Calculated by the Ultimate) b = Approach width h = Head from hump (P)	$Q = Q_{cal} (C_v/C_{vcal}) (C_d/C_{dcal}) (h/h_{cal})^{1.5}$ Where: Q = Flowrate C _v = Velocity coefficient (Calculated by the Ultimate) C _{vcal} = Velocity coefficient at maximum head C _d = Discharge coefficient (Calculated by the Ultimate) C _{dcal} = Discharge coefficient at maximum head h = Head from hump (P) h _{cal} = Maximum head
U-Throated Flume	$Q = (2/3)^{1.5} gn^{0.5} C_u C_v C_d b h^{1.5}$ Where: Q = Flowrate gn = gravitational acceleration (nominal value of = 980.66cm/s ²) C _u = Shape coefficient (Calculated by the Ultimate) C _v = Velocity coefficient (calculated by the Ultimate) b = Throat Diameter h = Head from bottom of the channel	$Q = Q_{cal} (C_v/C_{vcal}) (C_d/C_{dcal}) (C_u/C_{u_{cal}}) (h/h_{cal})^{1.5}$ Q = Flowrate Q _{cal} = Flowrate at maximum head C _v = Velocity coefficient (Calculated by the Ultimate) C _{vcal} = Velocity coefficient at maximum head C _d = Discharge coefficient (Calculated by the Ultimate) C _{dcal} = Discharge coefficient at maximum head C _u = Shape coefficient C _{u_{cal}} = Shape coefficient at maximum head h = Head h _{cal} = Maximum head

BS3680 FLUME	ABSOLUTE FORMULA	RATIOMETRIC FORMULA
<p>U-Throated Flume with Hump</p>	<p>$Q = (2/3)^{1.5}gn^{0.5}C_uC_vC_dbh^{1.5}$ Where: Q = Flowrate gn = gravitational acceleration (nominal value of = 980.66cm/s²) C_u = Shape coefficient (Calculated by the Ultimate) C_v = Velocity coefficient (calculated by the Ultimate) b = Throat Diameter h = Head from hump (P)</p>	<p>$Q = Q_{cal} (C_v/C_{vcal}) (C_d/C_{dcal}) (C_u/C_{ucal}) (h/h_{cal})^{1.5}$ Q = Flowrate Q_{cal} = Flowrate at maximum head C_v = Velocity coefficient (Calculated by the Ultimate) C_{vcal} = Velocity coefficient at maximum head C_d = Discharge coefficient (Calculated by the Ultimate) C_{dcal} = Discharge coefficient at maximum head C_u = Shape coefficient C_{ucal} = Shape coefficient at maximum head h = Head from hump (P) h_{cal} = Maximum head</p>

BS3680 Weir

When the PMD is a **BS3680 Weir** device, you can select from the drop-down menu the application you are setting up. You will be required where applicable, to enter dimensions in **measurement units** on that image, so the **Max Flow** can be calculated correctly.

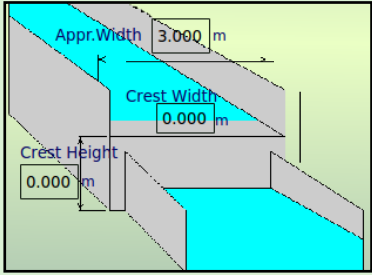
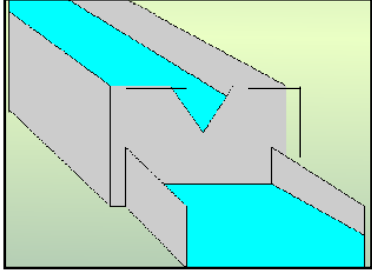
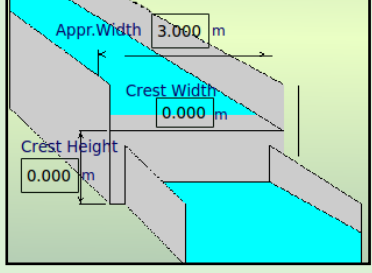
BS3680 WEIR	DIAGRAM	DIMENSIONS REQUIRED
<p>Rectangular Weir</p>		<p>Dimension A (Approach Width) Dimension B (Crest Width) Dimension C (Crest Height)</p>
<p>V-Notch 90°, 53.8° and 28.4° Weir</p>		<p>Not required</p>
<p>Broad Crested Rectangular Weir</p>		<p>Dimension A (Approach Width) Dimension B (Crest Width) Dimension C (Crest Height)</p>

BS3680 Weir Calculations

If the flow calculation is to be **Absolute** or **Ratiometric**, the flow will be calculated using the following formulae:

BS3680 FLUME	ABSOLUTE FORMULA	RATIOMETRIC FORMULA
Rectangular Weir	$Q = C_e \frac{2}{3} (2gn)^{0.5} b_e h_e^{1.5}$ Where: Q = Flowrate C _e = Discharge Coefficient (Calculated by the Ultimate) gn = gravitational acceleration (nominal value = 980.66 cm/s ²) b _e = effective approach width, where b = approach width (Dim. A) h _e = Effective head	$Q = Q_{cal} C_e / C_{cal} (h_e / h_{ecal})^{1.5}$ Where: Q = Flowrate Q _{cal} = Flowrate at maximum head C _e = Discharge coefficient (Calculated by the Ultimate) C _{ecal} = Discharge coefficient at maximum head h _e = Effective head h _{ecal} = Effective head at maximum head
V-Notch 90°, 53.8° and 28.4° Weir	$Q = C_e \frac{8}{15} \tan(\theta/2) (2gn)^{0.5} h^{2.5}$ Where: Q = Flowrate C _e = Discharge coefficient (Calculated by the Ultimate) theta = V-Notch angle gn = gravitational acceleration (nominal value = 980.66 cm/s ²) h = Head	$Q = Q_{cal} C_e(h) / C_e(h_{cal}) (h / h_{cal})^{2.5}$ Q _{cal} = Flowrate at maximum head C _e (h) = Discharge coefficient for head C _e (h _{cal}) = Discharge coefficient for maximum head h = Head h _{cal} = maximum head
Broad Crested Rectangular Weir	$Q = (2/3)^{1.5} C_e b (gnh^3)^{0.5}$ Q = Flowrate C _e = Discharge coefficient (Calculated by the Ultimate) b = Approach Width (Dim. A) gn = Gravitational acceleration (nominal value = 980.66 cm/s ²) h = Head	$Q = Q_{cal} C_e / C_{ecal} (h_e / h_{ecal})^{1.5}$ Q = Flowrate Q _{cal} = Flowrate at maximum head C _e = Discharge coefficient (Calculated by the Ultimate) C _{ecal} = Discharge coefficient at maximum head h _e = Effective head h _{ecal} = Effective head at maximum head

Area Velocity

When the PMD type is the Area Velocity method, you can select from many on-board channel shapes according to your application. A velocity measurement point must have been already set, as the **Max Flow** calculation is only possible when a MicroFlow, Speedy or other type of velocity sensor is available to provide a signal input proportional to the velocity of flow. You must enter dimensions in **measurement units** on the image.

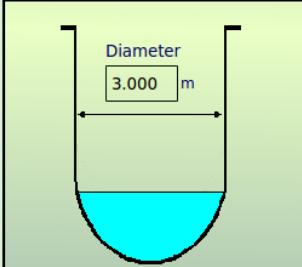
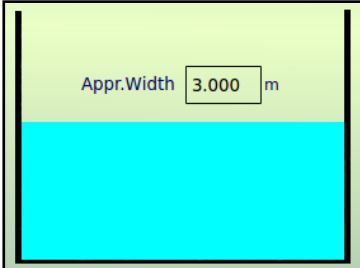
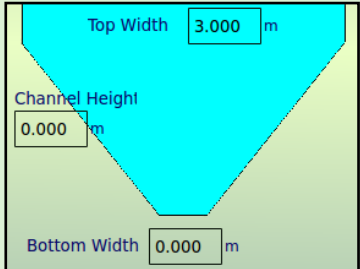
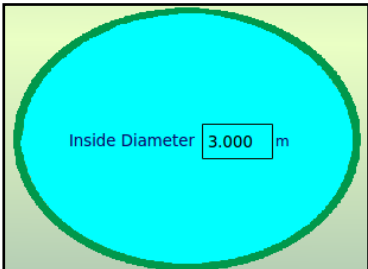
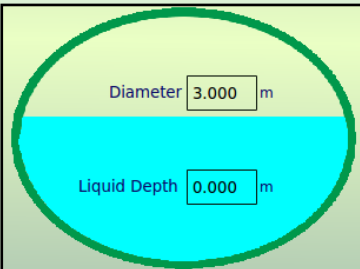
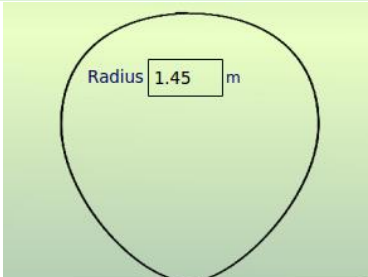
AREA VELOCITY	DIAGRAM	DIMENSIONS REQUIRED
<p>Circular Straight</p>		<p>Dimension A (Diameter)</p>
<p>Rectangular Channel</p>		<p>Dimension A (Approach Width)</p>
<p>Trapezoidal</p>		<p>Dimension A (Top Width) Dimension B (Bottom Width) Dimension C (Channel Height)</p>
<p>Full Pipe</p>		<p>Dimension A (Inside Diameter)</p>
<p>Round Pipe</p>		<p>Dimension A (Diameter) Dimension B (Liquid Depth)</p>
<p>Ovoid</p>		<p>Dimension A (Radius)</p>

Area Velocity Calculation

For Area Velocity, the flow calculation is automatically set as **Absolute**, the flow for your application will be calculated using the formula as follows:

AREA VELOCITY APPLICATION	ABSOLUTE FORMULA
Circular Straight	$Q = V \times A(h)$ Where: $Q = \text{Flowrate}$ $V = \text{Velocity}$ $A(h) = \text{Area at head}$
Rectangular Channel	$Q = V \times A(h)$ Where: $Q = \text{Flowrate}$ $V = \text{Velocity}$ $A(h) = \text{Area at head}$
Trapezoidal	$Q = Vh (b + mh)$ Where: $Q = \text{Flowrate}$ $V = \text{Velocity}$ $h = \text{Head}$ $b = \text{Bottom Width (Dim. B)}$ $m = (B-b)/d,$ $B = \text{Top Width (Dim. A)}$ $d = \text{Channel height (Dim. C)}$
Full Pipe	$Q = V \times A(h)$ Where: $Q = \text{Flowrate}$ $V = \text{Velocity}$ $A(h) = \text{Area at head}$
Round Pipe	$Q = V \times A(h)$ Where: $Q = \text{Flowrate}$ $V = \text{Velocity}$ $A(h) = \text{Area at head}$

Special

When the PMD is a **Special** device, you can select from the drop-down menu the application you are setting up. You will be required where applicable, to enter dimensions in **measurement units** on that image, so the **Max Flow** can be calculated correctly.

In the case of a **Palmer Bowlus** the point of measurement should be **half** of the value of the Flume size (Dim. A) upstream of the device. For a **H-Flume** the head measurement is taken at a point **downstream** from the flume entrance. For **V-Notch** weirs, the head is measured **upstream** of the weir plate at a minimum distance of **3 times maximum head** to ensure the surface of the liquid is not affected by turbulence or drawdown.

For a **Sluice Gate**, the head measurement is taken at a point **upstream** from the gate. For a **Sluice Gate Grid**, you will need to set up a **'Differential'** measurement point as the head measurement is taken from **upstream** and **downstream** and the difference between these is displayed on screen. The gate for both Sluice Gate applications is setup as a Level measurement point, and when setting up this application should be selected in the **Gate** parameter.

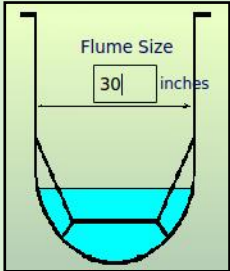
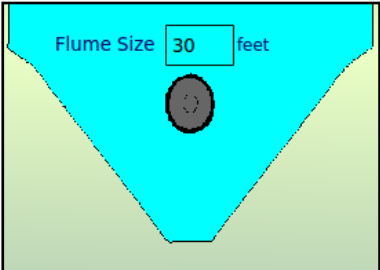
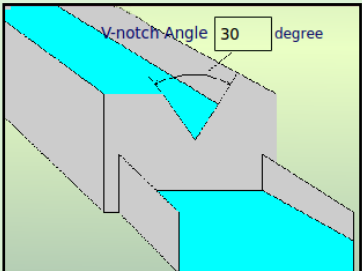
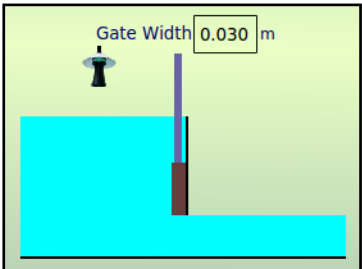
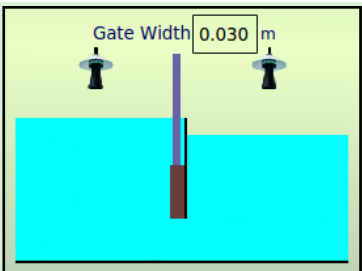
SPECIAL APPLICATION	DIAGRAM	DIMENSIONS REQUIRED
<p>Palmer Bowlus Flume</p>		<p>Dimension A (Flume size)</p>
<p>H-Flume</p>		<p>Dimension A (Flume size)</p>
<p>V-Notch Angle Weir</p>		<p>Dimension A (V-Notch angle)</p>
<p>Sluice Gate</p>		<p>Dimension A (Gate Width)</p>
<p>Sluice Gate Grid</p>		<p>Dimension A (Gate Width)</p>

Special Calculations

If the calculation is to be **Absolute** or **Ratiometric**, the flow will be calculated using the formula's as follows:

BS3680 FLUME	ABSOLUTE FORMULA	RATIOMETRIC FORMULA
Palmer Bowlus Flume	$Q = f(h)$ Where: Q = Flowrate f = is an 8 th degree polynomial solution for h (head)	$Q = Q_{cal}f(h)/f(h_{cal})$ Where: Q_{cal} = Flowrate at maximum head $f(h)$ = a polynomial solution for h (head) $f(h_{cal})$ = a polynomial solution for h_{cal} (maximum head)
H-Flume	$Q = f(h)$ Where: Q = Flowrate f = is an 8 th degree polynomial solution for h (head)	$Q = Q_{cal}f(h)/f(h_{cal})$ Where: Q_{cal} = Flowrate at maximum head $f(h)$ = a polynomial solution for h (head) $f(h_{cal})$ = a polynomial solution for h_{cal} (maximum head)
V-Notch Angle Weir (Non BS3680)	$Q = C_e 8/15^{\tan(\theta/2)} (2gn)^{0.5} (h = kh)^{2.5}$ Where: Q = Flowrate C_e = Discharge coefficient (Calculated by the Ultimate) θ = (V-Notch angle) gn = Gravitational acceleration h = Head kh = Compensated head	$Q = Q_{cal}(h+kh/h_{cal}+kh)^{2.5}$ Where: Q = Flowrate Q_{cal} = Flowrate at maximum head h = Head kh = Compensated head
Sluice Gate	$Q = \mu b h \sqrt{2gnH_p}$ Where: Q = Flowrate μ = Constant declared by customer b = Gate width submerged h = Gate opening gn = Gravitational acceleration (nominal value = 980.66 cm/s ²) H = Head H_p = movement of gate where: $H - h/2$	Not Available
Sluice Gate Grid	$Q = \mu b h \sqrt{2gnH_{diff}}$ Where: Q = Flowrate μ = Constant declared by customer b = Gate width submerged h = Gate opening gn = Gravitational acceleration (nominal value = 980.66 cm/s ²) H_{diff} = Difference in level between upstream and downstream.	Not Available

Universal

When the PMD is a **Universal** device, you can select from the drop-down menu the application you are setting up. You will be required, to enter breakpoints in **measurement units** on the **Breakpoints screen**, so the **Max Flow** can be calculated correctly. For all **universal** calculation applications, the point at which the head is measured should be chosen such that the surface of the liquid is not affected by turbulence.

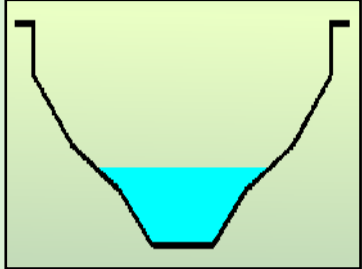
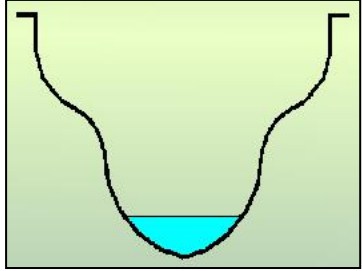
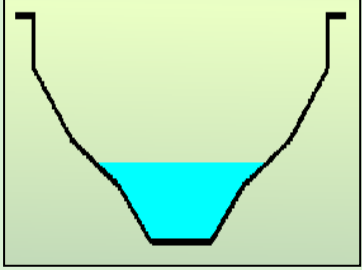
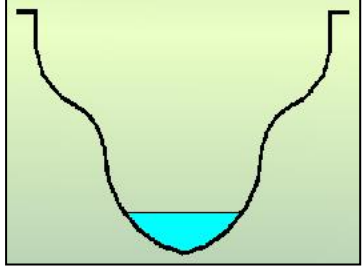
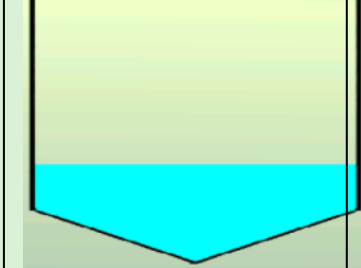
SPECIAL APPLICATION	DIAGRAM	DIMENSIONS REQUIRED
Universal Linear		<p>This flow calculation creates a linear approximation of the level/flow rate relationship. The desired number of level/flowrate breakpoints are to be entered in pairs on the Breakpoint screen, in values of head and corresponding flow in the chosen measurement units. A minimum of 2 and maximum of 32 pairs is required.</p>
Universal Curved		<p>This flow calculation creates a curved approximation of the level/flow rate relationship. The desired number of level/flowrate breakpoints are to be entered in pairs on the Breakpoint screen, in values of head and corresponding flow in the chosen measurement units. A minimum of 2 and maximum of 32 pairs is required.</p>
Universal Linear Area Velocity		<p>This flow calculation creates a linear approximation channel area for an Area * Velocity Flow calculation. The desired number of level/area breakpoints are to be entered in pairs on the Breakpoint screen, in values of head and corresponding area in the chosen measurement units. A minimum of 2 and maximum of 32 pairs is required.</p>
Universal Curved Area Velocity		<p>This flow calculation creates a linear approximation channel area for an Area * Velocity Flow calculation. The desired number of level/area breakpoints are to be entered in pairs on the Breakpoint screen, in values of head and corresponding area in the chosen measurement units. A minimum of 2 and maximum of 32 pairs is required.</p>
Custom V-Notch		<p>This flow calculation creates an approximation channel area for an Area * Velocity Flow calculation. The desired number of level/area breakpoints are to be entered in pairs on the Breakpoint screen, in values of head and corresponding area in the chosen measurement units. A minimum of 2 and maximum of 32 pairs is required.</p>

Universal Calculations

If the flow calculation is either **Absolute** or **Ratiometric**, the flow will be calculated using the formula's as follows:

AREA VELOCITY APPLICATION	ABSOLUTE FORMULA
Universal Linear	$Q = f(h)$ Where: $Q = \text{Flowrate}$ $f(h) = \text{flowrate function of head}$
Universal Curved	$Q = f(h)$ Where: $Q = \text{Flowrate}$ $f(h) = \text{flowrate function of head}$
Universal Linear Area Velocity	$Q = V \times A$ Where: $Q = \text{Flowrate}$ $V = \text{Velocity}$ $A = f(h)$ Where: $A = \text{Area}$ $f(h) = \text{flowrate function of head}$
Universal Curved Area Velocity	$Q = V \times A$ Where: $Q = \text{Flowrate}$ $V = \text{Velocity}$ $A = f(h)$ Where: $A = \text{Area}$ $f(h) = \text{flowrate function of head}$
Custom V-Notch	$Q = V \times A$ Where: $Q = \text{Flowrate}$ $V = \text{Velocity}$ $A = f(h)$ Where: $A = \text{Area}$ $f(h) = \text{flowrate function of head}$

Area Velocity Universal

When the water flow/velocity in the application falls to a certain level that the velocity sensor is unable to register a valid velocity, as set in **Min. Speed** by the amount set in **Speed Hysteresis**, flow calculations will switch to a pre-defined 32-point universal level to flow curve fit as set in Breakpoints. The vessel shapes available are below:

- 1 = Circular straight (U-channel), circular bottom, straight sides
- 2 = Rectangular
- 3 = Trapezoidal
- 4 = Round Pipe
- 5 = Fixed Pipe

Example:

P683 Max velocity = 6 m/s	A = 6m/s
P682 Min velocity = 0 m/s	B = 1.2 m/s
P693 Speed Min. Speed = 1 m/s	C = 0.8 m/s
P694 Speed Hysteresis = 0.2 m/s	D = -0.8 m/s
	E = -1.2 m/s
	F = -6 m/s

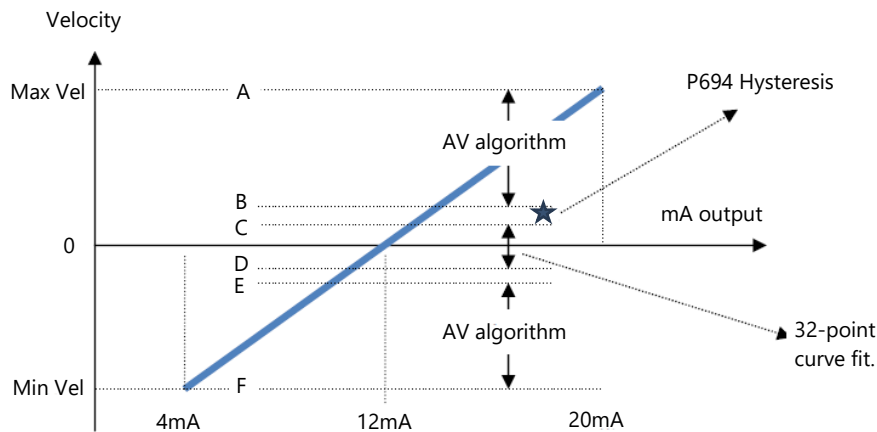

Assuming the velocity is positive and greater than 1.2 m/s i.e., the system operates in positive region between A and B. Flow rate will be positive which indicates forward flow and forward totaliser (P820, 821) will be incremented accordingly.

When the flow velocity falls below C (0.8 m/s), the calculation will be switch to a 32-point curve fit, which takes the level reading and outputs flow rate. The flow rate in this case is positive since it is the only direction available since it last registered. Therefore, the forward flow rate and totalisers will be registered. This continues as long as the flow velocity is above point E (-1.2 m/s).

There are 2 scenarios:

1. If the flow velocity rises above point B (1.2 m/s), the calculation will be reversed back to the AV algorithm, which calculates the flow according to Area x Velocity. The flow direction is still positive and hence the positive totalisers will be registered.
2. However, if the velocity continues to fall below point E (-1.2 m/s), the calculation will be reversed to AV algorithm, but the flow direction is now negative and negative totalisers (P504 – 506) will be registered. This will continue until flow velocity rises above point D (-0.8 m/s) when the 32-point curve fit will be reinstated.

Important Notice
Min Speed. and **Speedy Hysteresis** are only available when **PMD = A/V Universal.**
 For further information please consult your local Pulsar distributor.

Allocation

Selects the Point of Measurement to which the OCM Profile will be applied to.

Minimum head

This is used to enter the **distance**, above empty, that represents **zero head** and **flow**. This is used in PMD's where the zero reference is at a higher level than the channel bottom at the point of measure. Enter the distance in **measurement units**.

Maximum Head

Enter the **head** value that represents **maximum flow**, enter the value in **measurement units**.

Average Time

This determines the time period in **seconds** over which the Average Flow is to be calculated before being displayed.

Decimals

This determines the number of decimal places on the Flow reading that will be displayed during run mode.

Cut Off

This is used to select the minimum flow, in % of flow rate, which is to be totalised. Enter values in % of maximum flow.

K-Factor

This is used on **Venturi** and **Other** PMD types, to enter the K-factor which you will need to acquire from the PMD manufacturer.

Exponent

This determines the exponent value when the PMD is **Other**.

Roughness Coefficient (Ks)

When the PMD type **BS3680 Flume** is chosen, this is used to enter the roughness coefficient of the flume in millimetres. See table below for further details:

Surface Classification	Value of Ks	
	Good Example mm	Normal Value mm
Plastics etc. Perspex, PVC or other smooth faced Asbestos cement Resin-bonded glass-fibre moulded against smooth forms of sheet metal or well sanded and painted timber	0.03	0.06
Metal Smooth, machined, and polished metal Uncoated sheet metal, rust free Painted metal Galvanised metal Painted or coated casting Uncoated casting	0.003 0.015 0.03 0.06 0.06 0.15	0.006 0.03 0.06 0.15 0.15 0.3
Concrete In-situ or precast construction using steel formwork, with all irregularities rubbed down or filled in. In-situ or precast construction using plywood or timber framework Smooth troweled cement rendering Concrete with thin film of sewage slime	0.06 0.3 0.3 0.6	0.15 0.6 0.6 1.5
Wood Planned timber or plywood Well sanded and painted	0.3 0.03	0.6 0.06

Water Temperature

When the PMD type **BS3680 Flume** is chosen, this is used to enter the mean water temperature in °C.

μ - Factor

This value is obtained from the customer or manufacturer and entered to perform the **Max flow** calculation for Sluice Gate and Sluice Gate Grid OCM applications.

Gate

This value determines the depth of the submerged sluice gate in **measurement units**.

Method

Select the required calculation method, either **Absolute** or **Ratiometric**, both will give similar answers the difference being the information required to complete the calculation. For calculations using **Absolute**, once the Ultimate Controller has all of the information required it will work out the **Maximum flow** and display it on screen for you. For calculations using **Ratiometric**, it is normally sufficient to know the maximum flow at the maximum head.

Volume units

Determines the volume units that the flow is measured in.

The choices of units are detailed in the table below.

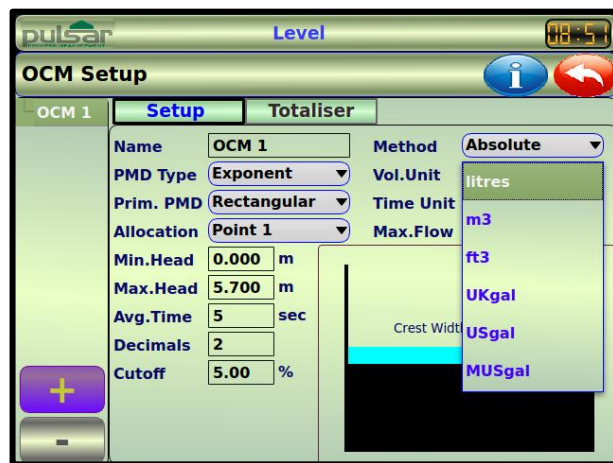

OPTION	DESCRIPTION
Litres	Flow will be calculated and displayed in Litres
Cubic metres (M ³)	Flow will be calculated and displayed in Cubic metres (M³)
Cubic Feet (ft ³)	Flow will be calculated and displayed in Cubic Feet (ft³)
UK Gallons	Flow will be calculated and displayed in UK Gallons (UKgal)
US Gallons	Flow will be calculated and displayed in US Gallons (USgal)
MUS Gallons	Flow will be calculated and displayed in Millions of US Gallons (MUSgal)

Time units

Select the time units to be used with the volume units to determine the desired flow rate.

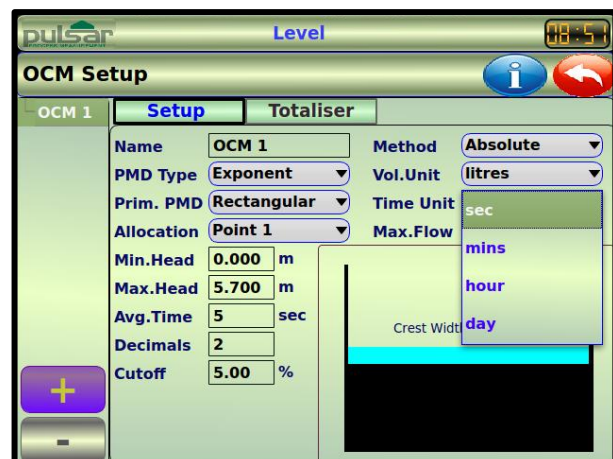

The choices of **Time Units** are detailed in the table below:

OPTION	DESCRIPTION
Seconds	Flow will be calculated and displayed in volume units per Second
Minutes	Flow will be calculated and displayed in volume units per Minutes
Hours	Flow will be calculated and displayed in volume units per Hours
Day	Flow will be calculated and displayed in volume units per Days

Max flow

When **Method = Absolute**, and all other relevant flow parameters have been entered, the **maximum flow** that occurs at the **maximum head** will be calculated and displayed here.

When **Method = Ratiometric**, enter the flow rate value in the chosen volume and time units that occurs at the **maximum head**.

Totaliser

Select **On** to enable OCM totalisers, where you can log daily totalised flow rate for the last ten days, in the desired **totaliser measurement unit**.



Totaliser unit

Determines the volume unit in which the flow is totalised.

The choices of unit are detailed in the table below.

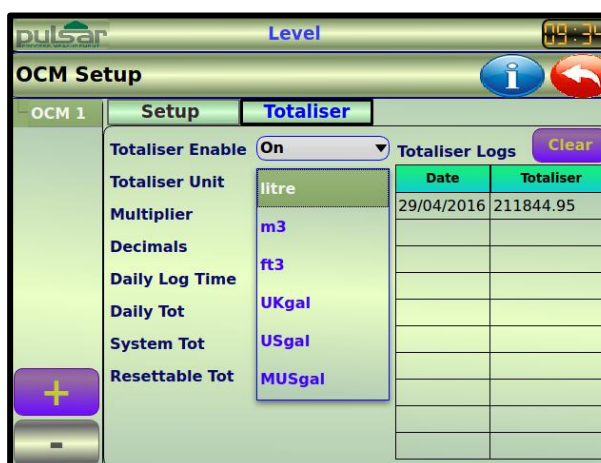

OPTION	DESCRIPTION
Litres	Flow will be calculated and displayed in Litres
Cubic metres (M ³)	Flow will be calculated and displayed in Cubic metres (M³)
Cubic Feet (ft ³)	Flow will be calculated and displayed in Cubic Feet (ft³)
UK Gallons	Flow will be calculated and displayed in UK Gallons (UKgal)
US Gallons	Flow will be calculated and displayed in US Gallons (USgal)
MUS Gallons	Flow will be calculated and displayed in Millions of US Gallons (MUSgal)

Multiplier

This determines the **factor** by which the chosen **Totaliser Unit** will be **multiplied** before incrementing the **totaliser**. This can be used if the totaliser increments by too large or too small amount for the general flow rate. Enter the factor by which the **totaliser unit** will be multiplied.

The choices of multiplier are detailed in the table below:



OPTION	DESCRIPTION
/1,000,000	Totaliser will increment every 1/1,000,000 Totaliser unit
/100,000	Totaliser will increment every 1/100,000 Totaliser unit
/10,000	Totaliser will increment every 1/10,000 Totaliser unit
/1,000	Totaliser will increment every 1/1,000 Totaliser unit
/100	Totaliser will increment every 1/100 Totaliser unit
/10	Totaliser will increment every 1/10 Totaliser unit
*1 Default	Totaliser will increment every 1 Totaliser unit
*10	Totaliser will increment every 10 Totaliser units
*100	Totaliser will increment every 100 Totaliser units
*1,000	Totaliser will increment every 1,000 Totaliser units
*10,000	Totaliser will increment every 10,000 Totaliser units
*100,000	Totaliser will increment every 100,000 Totaliser units
*1,000,000	Totaliser will increment every 1,000,000 Totaliser units

Decimals

Determines the number of decimal places used in the reading during run mode.

Daily Log Time

Sets the time of day when the daily totaliser will start a new day from zero and the previous daily totaliser is incremented in to the OCM Totaliser Log. The start time should be entered in 24-hour clock format.

Daily Totaliser

Displays the current value of the daily totaliser. This cannot be reset in run mode, only by accessing OCM and entering zero into the **Daily Totaliser** box can you reset this totaliser.

System Totaliser

Displays the current value of the, non-resettable totaliser. During run mode, this totaliser can be viewed via the **Totaliser** hot key '**Σ_{OCM}**'. Unlike the resettable totaliser this cannot be reset whilst in run mode, it can however be reset whilst in program mode by accessing OCM and entering zero in the **System Totaliser** value box.

Resettable Totaliser

Displays the current value of the resettable totaliser. During run mode, this totaliser can be viewed via the **Totaliser** hot key '**Σ_{OCM}**'. The resettable totaliser can also be cleared by pressing the clear button in the hot key menu displayed.

OCM Totaliser Logs

When an OCM application is enabled, the **OCM Totaliser Log** table shows the date and total flowrate for the last ten days, the first on the list are the most recent and last ones are the oldest. When all ten total audits are full, the oldest is pushed out and all totals increment through to allow the new days total to be registered in the first day's total audit parameter allocation.

To clear the logs recorded in program mode, pressing the **clear** button enables all of the Total Audits in the log table to be cleared to factory default values.

During **Run Mode** you can view the totaliser values by pressing the '**Σ_{OCM}**' hot key, from here the resettable totaliser can be reset by pressing the **clear** button which will revert the value back to 0.

Breakpoints

Level/Flow & Level/Area Breakpoints

Where the Primary Measuring Device or channel profile does not match the pre-programmed devices, a table of breakpoints can be used to define the relationship between level and flow (**PMD Type Universal Linear/Curved**) or level and area (**Universal Linear/Curved Area Velocity**). Breakpoints should be entered in pairs, a reading for level and its corresponding flow rate. The Linear option applies a linear relationship between the pairs of breakpoints. The Curved option applies a curve algorithm to the breakpoints entered.

To enter a breakpoint, select the relevant box and enter the required value via the popup keypad. You

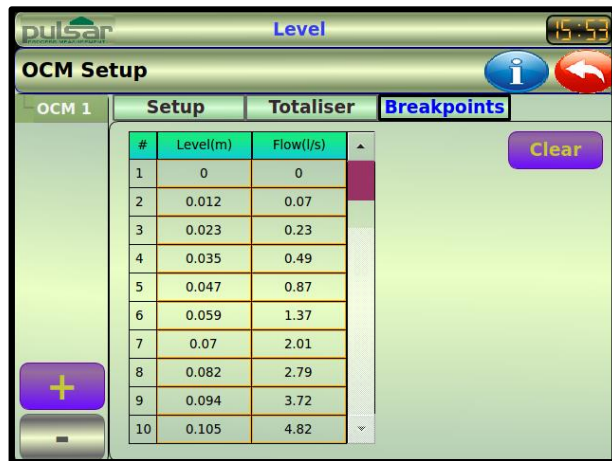

Clear

Selecting the **Clear** button will clear **all breakpoints** that have been set, to change an individual setpoints value simply select the setpoint box and use the pop up keypad to reset it to its default value or enter a new value.

Information

When you have completed setting up an OCM profile using either one of the 31 pre-programmed channel shapes, or by using a universal calculation, by selecting the  button the table shown to the right will appear giving details details of the calculated flow at incremental values of head. The increment depends on the span of the level input meter increments from zero (empty) to 100% of span (full). Up to 60 pairs of head/flow values will be shown.

h(m)	Flow(l/s)	h(m)	Flow(l/s)	h(m)	Flow(l/s)
0.000	0.00	2.000	15603.85	4.000	44134.35
0.100	174.46	2.100	16788.65	4.100	45799.69
0.200	493.44	2.200	18002.00	4.200	47485.46
0.300	906.50	2.300	19243.25	4.300	49191.43
0.400	1395.65	2.400	20511.79	4.400	50917.35
0.500	1950.48	2.500	21807.04	4.500	52662.99
0.600	2563.97	2.600	23128.46	4.600	54428.14
0.700	3230.98	2.700	24475.54	4.700	56212.58
0.800	3947.50	2.800	25847.81	4.800	58016.11
0.900	4710.32	2.900	27244.81	4.900	59838.52
1.000	5516.79	3.000	28666.10	5.000	61679.63
1.100	6364.67	3.100	30111.29	5.100	63539.24
1.200	7252.01	3.200	31579.97	5.200	65417.17
1.300	8177.15	3.300	33071.79	5.300	67313.25
1.400	9138.58	3.400	34586.38	5.400	69227.30
1.500	10135.00	3.500	36123.41	5.500	71159.16
1.600	11165.21	3.600	37682.57	5.600	73108.65
1.700	12228.13	3.700	39263.52	5.700	75075.64
1.800	13322.80	3.800	40866.00		
1.900	14448.31	3.900	42489.70		

TOUCH SCREEN TO CLOSE

Totalisers

Selecting the **Totalisers** button to enable the setup of general flow totalisers, where you can log totalised flow rate hourly, daily, weekly, monthly, and yearly, in the desired **totaliser measurement unit**. The Ultimate will also store a log of the last ten days totalised flow.

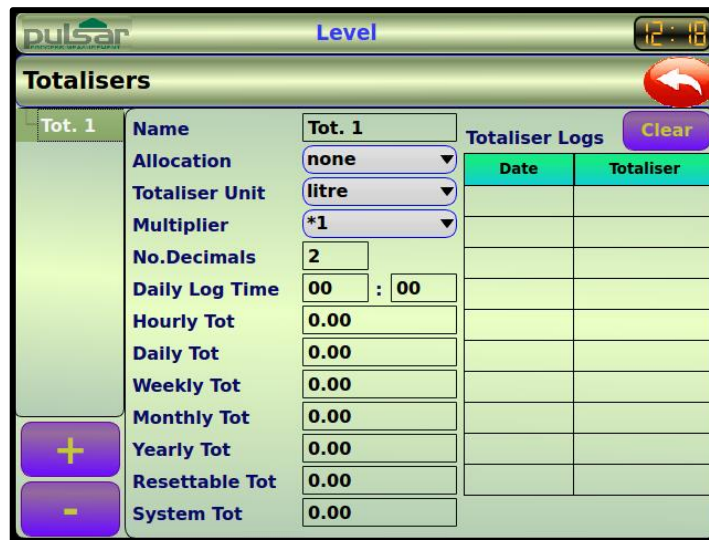

All current **Totaliser Profiles** will be listed by their given names in the tree list on the left-hand side of the screen.

Swap between the profiles by selecting a name on the tree list. New profiles can be added by pressing the **+** button or, when selected, delete existing ones by pressing the **-** button.

Name

If required, each individual totaliser profile can be given a specific name to suit the process or application and will be used to identify the profile in any subsequent display or menu allocation.

Allocation

Selects the **Flow** Point of Measurement to which the totaliser profile will be applied.

Totaliser unit

Determines the volume units that the flow is totalised in.

The choices of units are detailed in the table below.

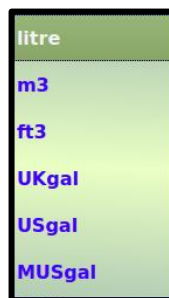

OPTION	DESCRIPTION
Litres	Flow will be calculated and displayed in Litres
Cubic metres (M ³)	Flow will be calculated and displayed in Cubic metres (M³)
Cubic Feet (ft ³)	Flow will be calculated and displayed in Cubic Feet (ft³)
UK Gallons	Flow will be calculated and displayed in UK Gallons (UKgal)
US Gallons	Flow will be calculated and displayed in US Gallons (USgal)
MUS Gallons	Flow will be calculated and displayed in Millions of US Gallons (MUSgal)

This determines the **factor** by which the chosen **Totaliser Unit** will be **multiplied** before incrementing the **totaliser**. This can be used if the totaliser increments by too large or too small amount for the general flow rate. Enter the factor by which the **totaliser unit** will be multiplied.

The choices of multiplier are detailed in the table below:



OPTION	DESCRIPTION
/1,000,000	Totaliser will increment every 1/1,000,000 Totaliser unit
/100,000	Totaliser will increment every 1/100,000 Totaliser unit
/10,000	Totaliser will increment every 1/10,000 Totaliser unit
/1,000	Totaliser will increment every 1/1,000 Totaliser unit
/100	Totaliser will increment every 1/100 Totaliser unit
/10	Totaliser will increment every 1/10 Totaliser unit
*1 Default	Totaliser will increment every 1 Totaliser unit
*10	Totaliser will increment every 10 Totaliser units
*100	Totaliser will increment every 100 Totaliser units
*1,000	Totaliser will increment every 1,000 Totaliser units
*10,000	Totaliser will increment every 10,000 Totaliser units
*100,000	Totaliser will increment every 100,000 Totaliser units
*1,000,000	Totaliser will increment every 1,000,000 Totaliser units

Decimals

Determines the number of decimal places used in the reading during run mode.

Daily Log Time

Sets the time of day when the daily totaliser will start a new day from zero and the previous daily totaliser is incremented in to the OCM Totaliser Log. The start time should be entered in 24-hour clock format.

Daily Totaliser

Displays the current value of the daily totaliser. This cannot be reset in run mode, only by accessing OCM and entering zero into the **Daily Totaliser** box can you reset this totaliser.

> **Totalisers** and entering zero into the **Daily Totaliser** box can you reset this totaliser.

Weekly Totaliser

Displays the current value of the weekly totaliser. This cannot be reset in run mode, only by accessing **OCM App.** > **Totalisers** and entering zero into the **Weekly Totaliser** box can you reset this totaliser.

Monthly Totaliser

Displays the current value of the monthly totaliser. This cannot be reset in run mode, only by accessing **OCM App.** > **Totalisers** and entering zero into the **Monthly Totaliser** box can you reset this totaliser.

Yearly Totaliser

Displays the current value of the daily totaliser. This cannot be reset in run mode, only by accessing **OCM App.** > **Totalisers** and entering zero into the **Yearly Totaliser** box can you reset this totaliser.

System Totaliser

Displays the current value of the, non-resettable totaliser. During run mode, this totaliser can be viewed via the **Totaliser** hot key ' Σ_{OCM} '. Unlike the resettable totaliser this cannot be reset whilst in run mode, it can however be reset whilst in program mode by accessing OCM and entering zero in the **System Totaliser** value box.

Resettable Totaliser

Displays the current value of the resettable totaliser. During run mode, this totaliser can be viewed via the **Totaliser** hot key ' Σ_{OCM} '. The resettable totaliser can also be cleared by pressing the clear button in the hot key menu displayed.

Totaliser Logs

When a General Totaliser has been setup for an application, the **Totaliser Log** table shows the date and total flowrate for the last ten days, the first on the list are the most recent and last ones are the oldest. When all ten total audits are full the oldest is pushed out and all totals increment through to allow the new days total to be registered in the first day's total audit parameter allocation.

To clear the logs recorded in program mode, pressing the **clear** button enables all of the Total Audits in the log table to be cleared to factory default values.

During Run Mode, you can view the totaliser values by pressing the ' Σ ' hot key, from here the hourly and resettable totalisers can be reset by pressing the **clear** button which will revert their values back to 0.

4.9 Display

On the Main Menu screen select



The Display Menu allows you to choose what is displayed on the screen of the Ultimate controller when in 'Run Mode'. When you select Display from the main menu you will notice that there are four tabs that contribute to the information displayed on the unit. These are **Main Display**, **AUX**, **Failsafe** and **Sec. Aux** all of which are described below.

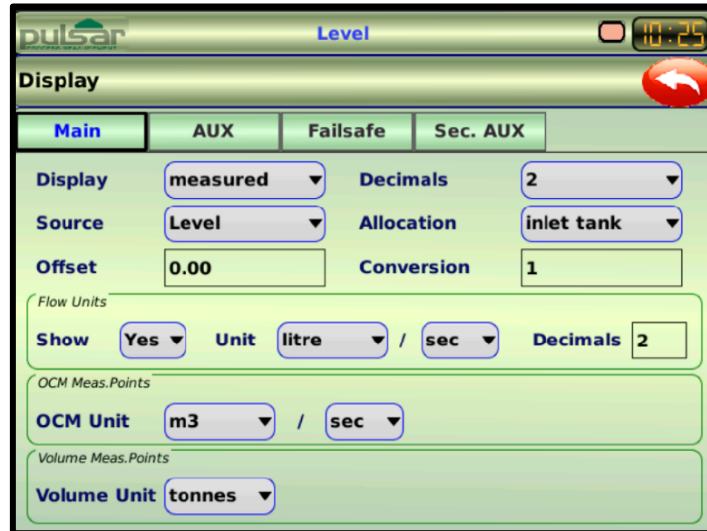

Main Display

The options viewed on the Main Display screen, their descriptions and their values are listed in the below table for ease of use:

Display

This will determine whether the reading displayed, in Run Mode, is in Measurement Units or percentage either of which can be selected from the drop-down box.

Source

This function chooses the mode that the display will relate to, it automatically sets the allocation to the correct options, units of measurement etc., for the mode/source selected from the drop-down box.

Offset

The value for Offset is entered in Measurement Units and will be added to the reading before it is displayed and it does not affect the relay setpoints or the mA output, only the reading on the display.

You can use this feature if, for example, you wanted to reference the reading to sea level, where you would enter the distance between the Empty Level and sea level. If the empty level point is below sea level, then enter a negative value.

Decimals

Determines the number of Decimal places used in the displayed reading during Run Mode.

Allocation

Depending on the Source selected this function allows the display to be allocated to a specific Measurement Point that has been setup in 'Application', 'Operation', all available Measurement Points, for the Source selected, will appear in the drop-down box.

Conversion

The reading is multiplied by this value before the information is displayed in run mode.

Inflow and Outflow

Show

Selecting 'Yes' will enable this function to show the inflow rate which is derived from the rate of change of level through a volume profile, and the pumped outflow rate (either derived from rate of change of level through volume profile, or from external flow meter/monitors).

Units

Selects the Volume and Time Units to be used to display the Inflow/Outflow rate when in Run Mode.

Decimals

Determines the number of Decimal places used in the displayed Flow Rate reading during Run Mode.

Volume Units

Selects the units to be used for Volume App measurement points/OCM units when in Run Mode.

AUX Display

The options in this menu allow you to choose additional information that can be displayed in either of the two auxiliary display lines on the main display screen when in run mode. This could be information such as the level in another point of measurement. Select the Aux 1 and/or the Aux 2 to enable, once enabled a 'tick' will appear in the appropriate box and the options for that display will be enabled.

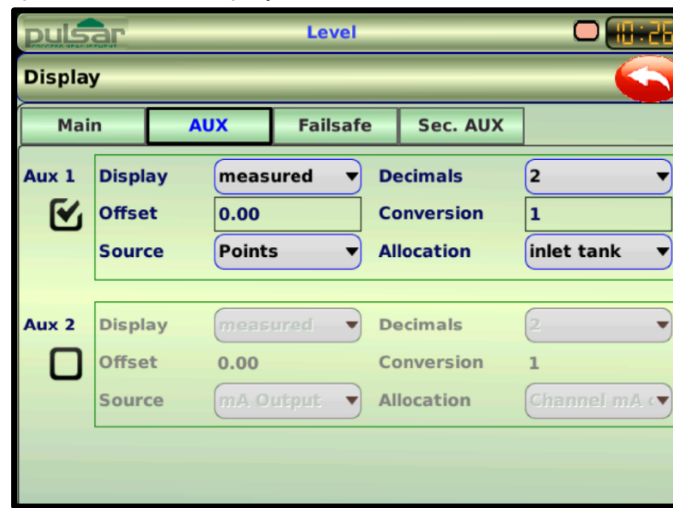

The options available for both Aux 1 and Aux 2 are the same and are as detailed below.

Display

This will determine whether the reading displayed, in Run Mode, is in Measurement Units or percentage either of which can be selected from the drop-down box.

Offset

The value for Offset is entered in Measurement Units and will be added to the reading before it is displayed and it does not affect the relay setpoints or the mA output, only the reading on the display.

Source

This function chooses the mode that the display will relate to, it automatically sets the allocation to the correct options, units of measurement etc., for the particular mode/source selected from the drop-down box.

Decimals

Determines the number of Decimal places used in the displayed reading during Run Mode.

Conversion

The reading is multiplied by this value before the information is displayed in run mode.

Allocation

Depending on the Source selected this function allows the display to be allocated to a specific Measurement Point that has been setup in 'Application', 'Operation', all available Measurement Points, for the Source selected, will appear in the drop-down box.

Failsafe

This screen allows you to view or change the time and mode in the event of a failsafe condition.

In the event of a fail-safe condition occurring of the principal measurement point, the failsafe timer determines the time before the fail-safe mode is activated.



Fail Time

In the event of a Failsafe condition occurring the Fail Time determines the time that elapses before the Failsafe mode is activated.

If the timer activates, the unit goes into Failsafe, as determined by Display Failsafe, Relay Failsafe and mA Output Failsafe. When this happens, you will see the message "Failed Safe!" on the display, along with a message explaining why (lost echo or transducer fault, for example).

When a valid measurement is obtained then the display, relays and mA output will be restored, and the timer is reset.

Fail Mode

By default, if a Failsafe condition occurs, then the display, relays and the mA output **hold** their last known values until a valid reading is obtained. If required, the Failsafe condition can be changed so that the unit goes to **high** (100% of span), or **low** (empty).

Important Notice

In the event of a **fail-safe** condition occurring, the display, relays and mA Output can be configured to fail to a condition which is independent of each other. To set independent **Relay > Setpoints > Failsafe**. And for independent **mA Output Failsafe** see **mA Output > Source > Failsafe**.

Secondary Auxiliary

This screen allows you to select up to 6 secondary auxiliary displays, which when setup will appear in run mode displaying the relevant information. The secondary displays will be displayed in the place of the level bar graph.



Enable

This enables the secondary auxiliary displays to be selected.

Allocation

You can select up to 6 points of measurement, as set in **Application > Operation**. Further details of how to do this can be found in **Section 4.2**.

Display

This will determine whether the reading displayed, in Run Mode, is in Measurement Units or percentage of the measurement's span

Decimals

Determines the number of Decimal places used in the displayed reading during Run Mode.

Offset

The value for Offset is entered in Measurement Units and will be added to the reading before it is displayed and it does not affect the relay setpoints or the mA output, only the reading on the display.

You can use this feature if, for example, you wanted to reference the reading to sea level, where you would enter the distance between the Empty Level and sea level. If the empty level point is below sea level, then enter a negative value.

Conversion

The reading is multiplied by this value before the information is displayed in run mode.

4.10 mA Outputs

On the Main Menu screen select 

The mA Output menu is used to configure the mA outputs for their intended use. The tree list on the left side of the screen can be used to select between mA1 and mA2 on the hardware. If any additional Interface Boards (IFB) have been registered on the PBUS, the list will include any extra ma Outputs available.

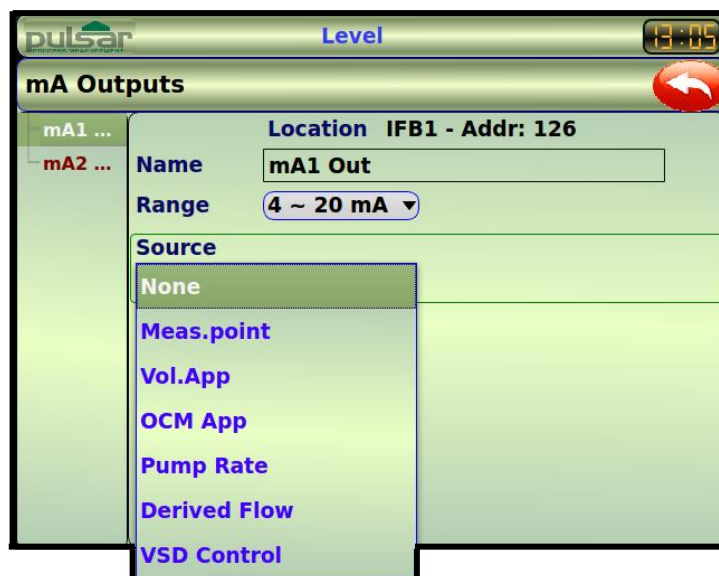

Location

Displays which Interface Board the selected mA Output is located upon and its address on the PBUS.

Name

This defaults as mA1 Out (for mA1) or mA2 Out (for mA2) but can be renamed to something more application specific if required.

Range

Used to select the operational range of the mA Output from the following choices.

OPTION	DESCRIPTION
0 – 20mA	mA output directly proportional to the mA Source selected, so if the reading of the selected source is 0% the output is 0mA. If the reading is 100% the output is 20mA.
4 – 20mA	mA output directly proportional to the mA Source selected, so if the reading of the selected source is 0% the output is 4mA. If the reading is 100% the output is 20mA
20 – 0mA	mA output inversely proportional to the mA Source selected, so if the reading of the selected source is 0% the output is 20mA. If the reading is 100% the output is 0mA.
20 – 4mA	mA output inversely proportional to the mA Source , selected so if the reading of the selected source is 0% the output is 20mA. If the reading is 100% the output is 4mA.

Source

Determines the measurement, mode, or application that the mA Output will respond to, from the following options.

OPTION	DESCRIPTION
Meas. Point	mA Output will be relative to the Measurement Point selected.
Vol. App	When a Volume Application is used the mA Output can be configured to be relative to Volume .
OCM App	When an OCM Application is used the mA Output can be configured to be relative to OCM flow.
Pump Rate	When in use the mA Output can be used to provide an output relative to Pump Rate .
Derived Flow	When in use the mA Output can be used to provide an output relative to Derived Flow .
VSD Control	When in use the mA Output can be used to provide an output relative to VSD Control .

Having selected the **Source** for the mA Output you will see the screen shown to the right, detailing further options that can be used to complete the setup of the mA Output.

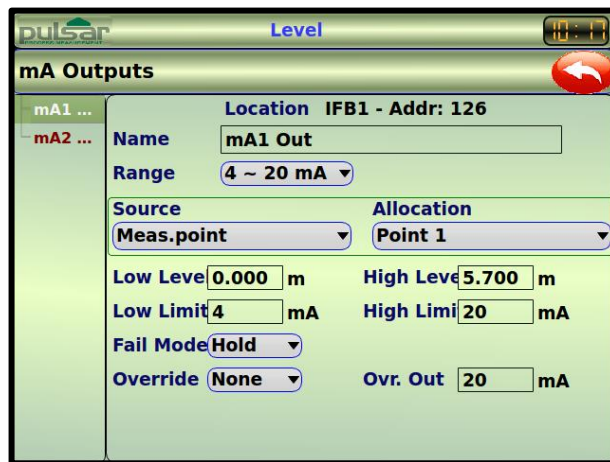

Allocation

Allocates the selected mA Output to a specific point of measurement.

By **default**, the mA Output will represent the **empty** or **zero** point (**0** or **4mA** dependant on the **Range** selected) and **100%** of the operational range (**20mA**), but you may wish to have the output represent a section of the operational range.

Low Level

Determines the **Low Level**, in the **measurement units** of the selected **Source**, that the minimum mA **range** will represent.

Low Limit

Determines the lowest level that the mA output will fall to in representing the **Low Level**.

High Level

Determines the **High level**, in the **measurement units** of the selected **Source**, that the maximum mA **Range** will represent.

High Limit

Determines the highest level that the mA output will rise to in representing the **High Level**.

Fail Mode

This determines what happens to the mA output in the event of the unit going into fail-safe mode. The **default** is to do the same as the **display failsafe**, but this can be overridden to force the mA output to an independent failsafe mode as follows:

OPTION	DESCRIPTION
Default	mA Output will fail as per display failsafe.
Hold	mA Output will hold its last known value.
Low	mA Output will fail to its low condition, 0 or 4mA dependent on mA Range selected.
High	mA Output will fail to its high condition, 20mA .
Very High	mA Output will fail to the highest value possible, typically 23.5mA, regardless of the settings of High Level and High Limit .
Default	mA Output will fail as per display failsafe.

Override

OPTION	DESCRIPTION
None	No override mode is enabled
Run On	This option allows the Duty pump to continue operating below its normal "OFF" point, as set in Pump Advanced - Run On . The mA output will be forced to the Override Out value during a Pump Run On event.
Exercise	Pumps are allowed to run after a specified Idle Time for a determined period of Exercise time, as set in Pump Advanced - Exercise . The mA output will be forced to the Override value during a Pump Exercise event.

Override Out

This value is set to determine the value of the mA output when an Override mode is selected.

4.11 Compensate

On the Main Menu screen select

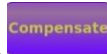

The Compensate menu is used to configure how the unit will determine and compensate for variations in temperature and sound velocity. The tree list on the left side of the screen can be used to select the transducer required. If any additional Interface Board (IFB) have been registered on the PBUS, the list will include any extra transducers available.

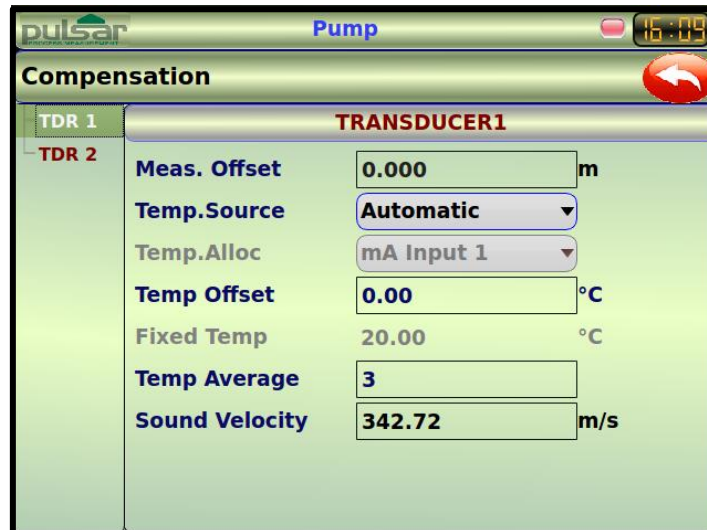

Meas. Offset

The value of this parameter is added to the measured distance, in **Measurement Units**.

This Offset will be added to the level, as derived from the transducer, and will affect everything including the reading on the display, and any relay setpoints and mA outputs allocated to the measurement point.

Temp. Source

Determines the source of the temperature measurement. By **default**, it is set to **Automatic**, which will automatically detect if a temperature sensor is available from the transducer. If for any reason, no temperature input is received, then the **Fixed Temp** value is used.

The temperature source can be specifically set as follows:

OPTION	DESCRIPTION
Automatic	Will automatically select the Transducer temperature sensor, if available, or Fixed temperature if no temperature sensor is found.
Transducer	Will always use the temperature reading from the Transducer
Fixed	Will always use the entered Fixed temperature
Ext. Range A	Uses an optional external temperature sensor with an operating range of -25°C to 50°C.
Ext. Range B	Uses an optional external temperature sensor with an operating range of -25°C to 125°C.

Temp. Allocation

Determines which input is used to provide the temperature reading when Temp. Source is Transducer or an External temperature sensor.

Temp. Offset

Used to Offset the temperature reading when the Temp. Source is set for either Automatic or Transducer. If the reading obtained is different to that expected or as checked against another temperature device an Offset can be entered so that the desired temperature reading is applied e.g., the reading being obtained from the transducer is being recorded as 24°C but the actual temperature is 19°C, then a Temp. Offset of -4 (minus four) can be entered to correct the temperature reading being recorded.

Fixed Temperature

This option is used to set the temperature, in degrees centigrade, to be used if **Temp. Source** is set to **Fixed**.

Temp Average

Determines the number of temperature readings or cycles over which the temperature will be averaged before the temperature reading is updated.

Sound Velocity

This option parameter allows for the velocity of sound to be changed according to the atmosphere the transducer is operating in. By default, the velocity is set for sound travelling in air at an ambient temperature of 20 degrees centigrade at 342.7m/sec.

4.12 Stability

On the Main Menu screen select



The Stability menu is used to configure how the unit will respond to a change in level. The tree list on the left side of the screen can be used to select the transducer required. If any additional Interface Board (IFB) have been registered on the PBUS, the list will include any extra transducers available.

Rate

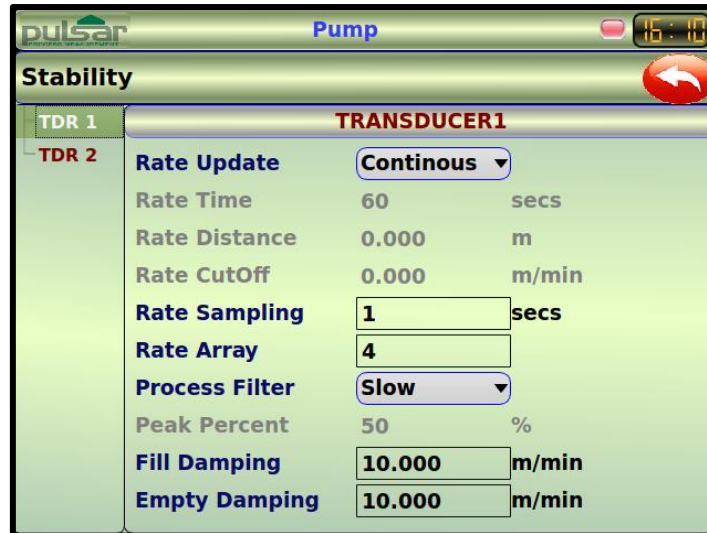

Rate Update

This option determines the way in which the rate is calculated.

Continuous - the rate is calculated and displayed continuously, i.e., any change seen from shot to shot are calculated and displayed.

Values – when set to use **values** then the values set in **Rate Time** and **Rate Distance** are used to calculate and display the rate.

Rate Time

Sets the period (in seconds) over which the material level rate of change is averaged before the rate value is updated. If the **Rate Distance** is exceeded before the **Rate Time** has expired, then the rate value will be updated immediately.

Rate Distance

Sets the **Distance**, in **Measurement Units**, over which the material level must change before the rate value is updated. If the **Rate Time** expires before the **Rate Distance** is exceeded, then the rate value will be updated immediately.

Rate Cut Off

This option is used to select the minimum Rate to be calculated, below which the rate value will not be updated and can be used to eliminate unwanted spurious updates from effects of ripples/waves on the surface of the material.

Rate Sampling

Determines how often the unit will check to see if a change of level has occurred in order to calculate a rate of change.

Rate Array

Sets the number of 'samples' used to average the rate value. The higher the number of samples used the slower the rate update will be.

Process Filter

Adjusts the speed of response of the ultrasonic level measurement. Can be used to allow a quicker response in fast moving applications.

OPTION	DESCRIPTION
Fast	level will be updated every measurement cycle.
Medium	level will be updated as the average of every 8-measurement cycles.
Slow (Default)	level will be updated as the average of every 16-measurement cycles.

Peak Percent.

This option is only available when measuring a Solids material, **Application > Distances > Material > Solids**, and is used to determine the point at which the measurement is taken, within the established gate of the selected echo, to compensate for any error that maybe caused by "angles of repose" presented by the way the material settles. Please consult Pulsar, for further information and assistance on changing the value of this parameter.

Damping

Damping is used to damp the display, to enable it to keep up with the process but ignore minor surface fluctuations.

Fill Damping

Determines the **maximum rate** at which the unit will respond to an **increase in level**. It should be set slightly higher than the maximum vessel fill rate, by default it is set to 10m/min.

Empty Damping

Determines the **maximum rate** at which the unit will respond to a **decrease in level**. It should be set slightly higher than the maximum vessel empty rate, by default it is set to 10m/min.

4.13 Echo Process

On the Main Menu screen select 

The Echo Process menu is used to configure how the unit will respond to selecting the echo used to provide the level measurement. The tree list on the left side of the screen can be used to select the transducer required. If any additional Interface Board (IFB) have been registered on the PBUS, the list will include any extra transducers available.

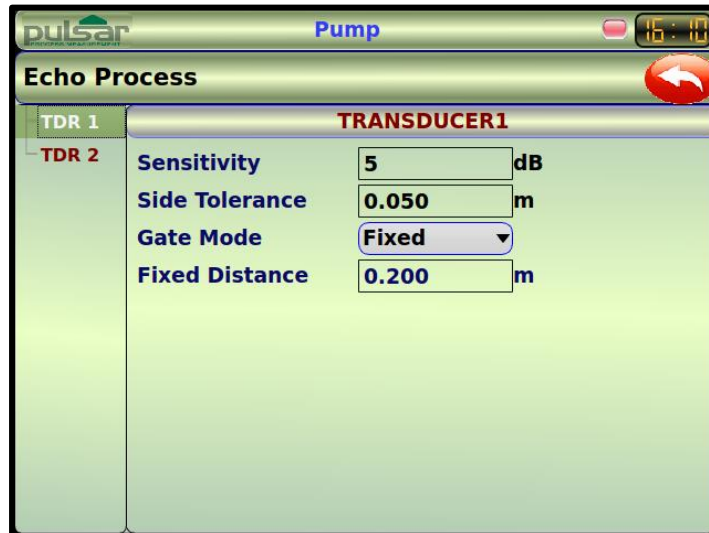

Sensitivity

Sets the minimum DATEM level which can be increased to cover a high noise floor in noisy applications. It is recommended that this parameter not be changed unless necessary as any echo below the DATEM will be ignored. Default 5dB (50mV).

Side Tolerance

Sets the distance by which the DATEM trace will be separated from the raw echo when the DATEM trace covers an echo returned from an obstruction. Default 0.05m.

Gate Mode

This parameter determines the operation of the gate that is established around the processed echo and is used to track the echoes movement and update the display.

Fixed

If set to Fixed, then the width of the gate is determined by the value of Fixed Distance.

Calculated

When set to Calculated then the gate width is automatically calculated and updated according to the values of Stability > Rate Update > Rate Time and Rate Distance along with Fill Damping and Empty damping.

Fixed Distance

This option determines the width of gate to be used in tracking an echo and under normal circumstances will not require changing, but it can be increased in the cases where the surface is moving extremely fast (in excess of 10m/min) to ensure smooth processing of the changing level.

4.14 Remote Alarms

On the Main Menu screen select



Remote Alarms

When an internal GSM Modem is fitted, SMS messages can be sent on various events in the application setup. The messages can be associated and triggered by the operation of a relay output, or a Logic point, or an SMS message can be sent on an interval basis with detailing the value of one memory index.

Consult Pulsar or your local distributor for more details),

The screenshot shows the 'Remote Alarms' configuration screen. At the top, there's a 'Level' indicator and a clock showing 16:35. The screen is divided into several sections:

- Event SMS:** 'Enable' is checked, and 'Delay' is set to 30 sec.
- Interval SMS:** 'Enable' is checked, 'Interval' is 60 mins, and 'Memory Index' is 92 (labeled as 'Sump level percent'). All days (Mon-Sun) are checked.
- Start/Stop Time:** Start Time is 00:00 and Stop Time is 23:59.
- Telephone Numbers:** Six input fields labeled #1 through #6 are provided for entering phone numbers.

Event SMS

Enable

When Event SMS is enabled, the unit will send out a text message when a SMS Event is reached. You can select what events are to be classed as a SMS event by clicking on the tick boxes located in the relays menu and the Logical output menu system.

Delay

If an SMS event is reached this parameter delays the time it takes for the unit to send the SMS to remote telephone number.

Interval SMS

Enable

When Interval SMS is enabled, the Ultimate will send out an SMS regardless of a SMS Event being reached.

Interval

This parameter determines how often the unit will send out an SMS to the allocated telephone number.

Memory Index

This Parameter determines what information is to be sent as an SMS when the interval expires. The default for this parameter is 92 which equates to the Sump Level Percentage.

This Parameter can be changed to any memory index value. (See Memory index)

Interval Days

These Tick boxes allow you to select which days you want the Ultimate to send out Interval messages.

Interval Time

These parameters allow you to input the time you want the interval SMS to be active as default the parameters are set to allow the unit to send out interval SMS 24/7.

Telephone Numbers

You can enter up to 6 telephone numbers, to which SMS messages will be sent.

4.15 Logical Output

On the Main Menu screen select



Logical Output

The Logical output function on the Ultimate pump controller allows the user to configure customized alarms and controls, by combining variables from the **Shared Memory Map** (please see Shared memory map in **Appendix A**). Variables are tested against setpoint values to resolve a True or False output.

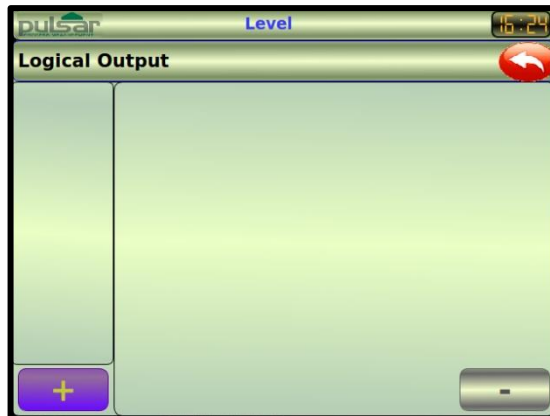

To Begin your configuration of a Logic Output, click on the  icon. Here you can add up to 20 Logic profiles.

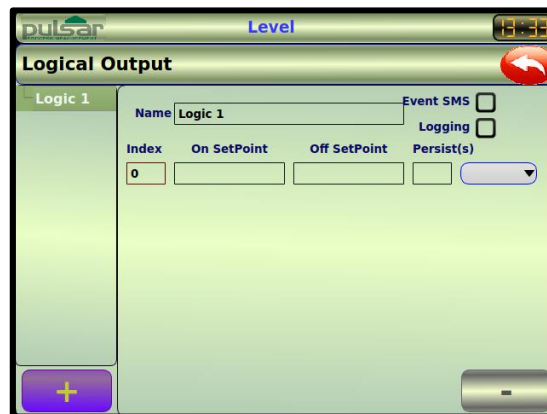

Name

This allows you to name your Logical Output

Event SMS

By ticking this box when a Logical output is true/active a SMS will be sent indicating the logic has been activated (Please see the previous chapter- Remote Alarms)

Logging

This checkbox determines if the change of logic state is printed to the event log.

Index

This parameter allows you to select which variable in the **Shared Memory Map** you want to add in to your logical output.

On Set point

This Parameter determines the on setpoint (true) of your Logic Output.

Off Setpoint

This Parameter determines the off-set point (false) of your Logic Output.

Persist

This is a delay time for the chosen variables to be in a state to change the logic output before the output changes. This can be used to implement time delays or filter out momentary operations of the output.

Logical Operators

By Clicking on the drop-down box a list of Logic Operators will appear, these are used to combine your Logic Inputs.



AND

An AND operator will give an output only if the Inputs have reached there ON Setpoints.

OR

An OR operator will give an output if any of the inputs have reached there ON Setpoints.

NAND

A NAND operator will give an output if only one of the inputs has reached its ON Setpoint or if none of the Inputs have reached the On Setpoints.

NOR

A NOR operator will only give an output when the Logic inputs are Off/False.
An example of the logic commands in truth table form are shown below:

AND			OR			NAND			NOR		
A	B	X	A	B	X	A	B	X	A	B	X
0	0	0	0	0	0	0	0	1	0	0	1
0	1	0	0	1	1	0	1	1	0	1	0
1	0	0	1	0	1	1	0	1	1	0	0
1	1	1	1	1	1	1	1	0	1	1	0

Logic Examples

In this example, the Logical Output has been configured so if there is an inflow Rate of 40 l/s or greater and Pump1 is blocked the Logical Output will be activated/become true and a Logic relay (if configured in relay menu) will change state.

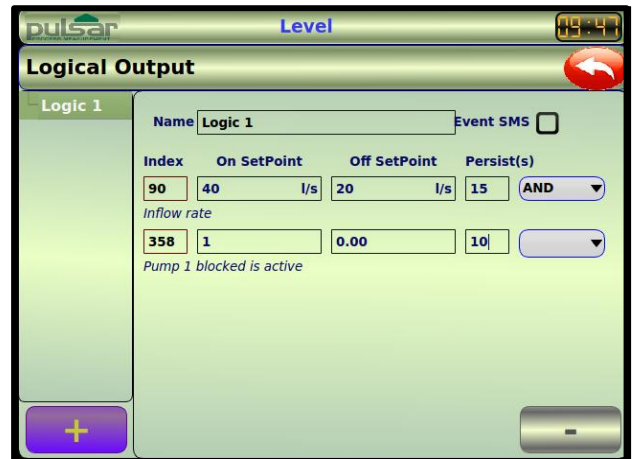

In this example, the Logical output has been configured so if the level is higher than 2.5metres, the Pump relay is on and the pumped rate is less than 5 l/s the Logical Output will be activated, a SMS will be sent and a Logic Relay will change state.

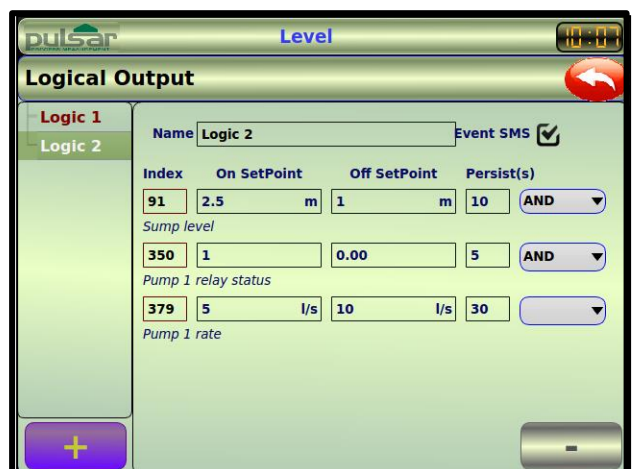

4.16 Simulation

On the Main Menu screen select

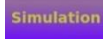

Simulation is used to simulate the application and confirm that all parameters and relay setpoints have been entered as expected. During simulation, there is a choice of whether the relays will physically change state (hard simulation) or not (soft simulation), but the pump icons and relay status indicators will always change colour as programmed, and the current output will change. If you want to test the logic of the system that the relays are connected to then select a hard simulation, but if you do not want to change the relay state, then select a soft simulation. There are two simulation modes, **automatic** and **manual**.

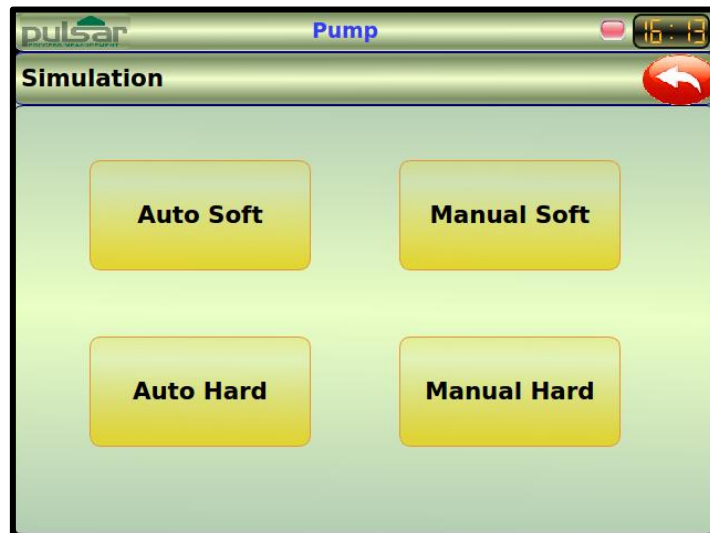

Manual

You have two choices Manual Soft and Manual Hard, if you wish to test the logic of the system that the relays are connected to then select a hard simulation, but if you do not want to change the relay state, then select a soft simulation.

In manual simulation, using the arrow keys  will allow you to move the level up and down as required.

To test the function of any Digital Inputs that have been programmed select the corresponding DIN 'check' box and the appropriate function/status will be initiated.

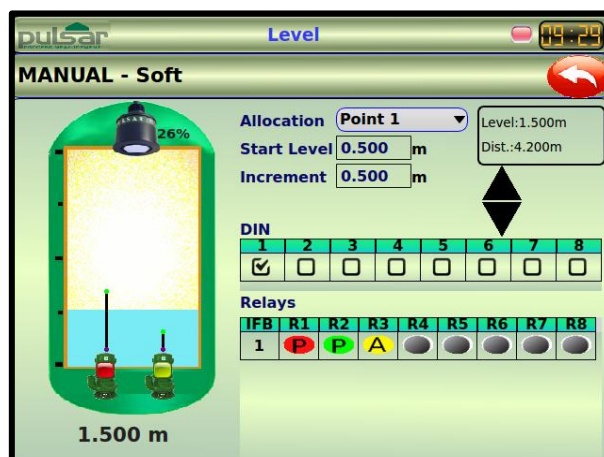

Allocation

Used to select the Point of Measurement that is to be simulated.

Start Level

When using automatic simulation, this parameter can be used to pre-determine the point at which the simulated level will start at and return to. This can be used to simulate the lowest point to which the level would normally operate.

Increment

Used to determine the increment that the level will increase/decrease by each time the  arrow key is selected. By **default**, simulation mode will move by **0.1m** steps in manual simulation, but this value can be changed as required.

Automatic

You have two choices Manual Soft and Manual Hard, if you wish to test the logic of the system that the relays are connected to then select a hard simulation, but if you don't want to change the relay state, then select a soft simulation.

Automatic, simulation will move the level up and down between empty level or the pre-determined **Start Level** and the Pump/Control relay switch points, if you wish to change the direction of the level movement e.g. to go beyond relay setpoints, this can be done by using the  arrow keys.

To test the function of any Digital Inputs that have been programmed select the corresponding DIN 'check' box and the appropriate function/status will be initiated.

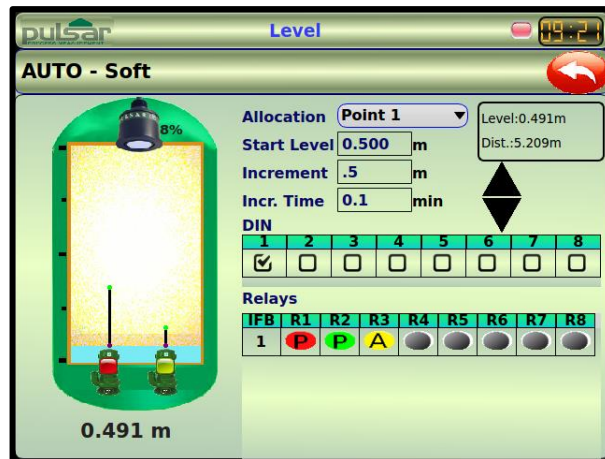

Allocation

Used to select the Point of Measurement that is to be simulated.

Start Level

When using automatic simulation, this option is used to pre-determine the point at which the simulated level will start at and return to. This can be used to simulate the lowest point to which the level would normally operate.

In automatic mode, the rate at which the level will move up and down is determined by the **Increment** and the **Incr. Time** and can be changed as required. To increase the rate at which the level moves **increase** the **Increment** or **decrease** the **Incr. Time**. To decrease the rate at which the level moves decrease the **Increment** or increase the **Incr. Time**.

Increment

Used to determine the increment that the **level** will **increase/decrease** by, over the time period selected by **Incr. Time**.

Inc. Time

Determines the **time** period over which a change in level, as set by the **Increment**, will take place.

CHAPTER 5 ADVANCED CONFIGURATION

Enter Program Mode and enter the  menu and the Adv. Config. main menu will be displayed, this screen contains the various sub menus which are used to set up and add additional hardware to the PBUS, configuration of digital communications, adding user accounts, setting of Date/Time, and power settings.



5.1 Modules

From the Adv. Config. menu select the  icon.

This menu is used to add hardware (modules) to the PBUS for use with the Ultimate controller. Performing a 'Live list' will allow you to see the Modbus address of each of the modules found connected to the Ultimate. There are six main types of modules that can be chosen as follows.

1. Interface (IFB)
2. Power Monitor (PMB)
3. FlowPulse (FP)
4. Speedy (Speedy)
5. MicroFlow (MFL)
6. Input Module

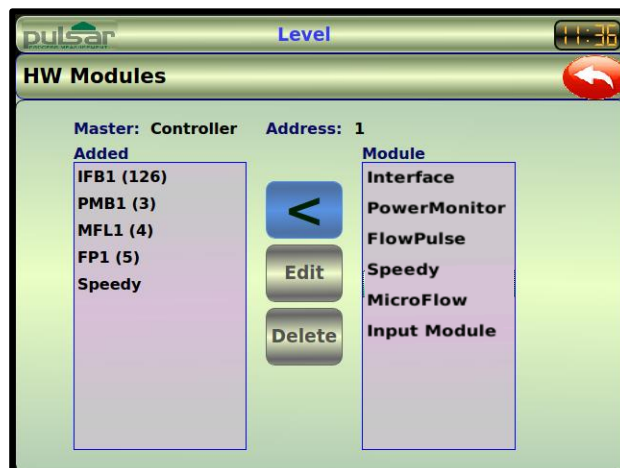

Interface (IFB)

As standard Ultimate comes with an Interface (IFB1) already fitted, however, if required additional Interface (IFB) can be added to expand the system's I/O. Each Interface is powered by the PBUS and will provide 2 dB ultrasonic transducer inputs, 2 mA inputs, 2 mA outputs, 8 relays and 8 digital inputs.

Power Monitor

This option allows connection of power monitors to the controller so that you can monitor energy use and additional specific electrical parameters of a load.

FlowPulse

This option allows the connection of Pulsar Flow Pulse flow monitors, which are used to provide control and monitoring based on real time flow.

Speedy

This option allows you to connect a velocity sensor to the controller, in order to provide measurement of flow velocity in channels and pipes. Only one speedy device can be attached to the Ultimate at one time, it also does not require you to assign a PBUS address as it connects directly to the controller itself, via Modbus RS485 communications.

MicroFlow

This option allows the connection of Pulsar MicroFlow velocity sensors, which are used to provide reliable flow velocity measurements in all open channels.

Input Module

Input Interface Module provides 40x Digital inputs, 8x mA inputs, and 3x pulse/counter inputs. Up to 3 Input modules can be connected to the Ultimate controller's PBUS.

Add

To add a device to the PBUS select the device from the Module list and press the  button and it will be moved to the Added column and automatically assigned a PBUS address.

e.g. FP1 (5) Device is FlowPulse #1 with PBUS address 5

Up to 125 individual devices (modules) can be connected to the controller at any given time.

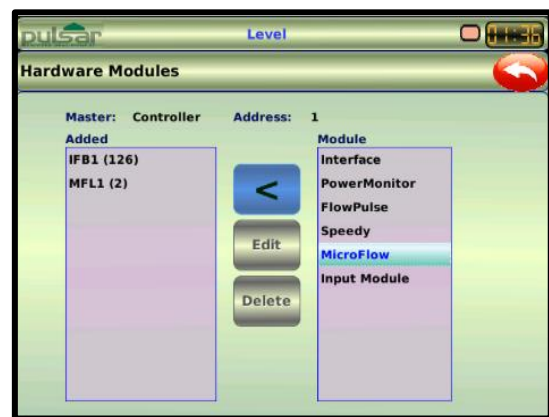



Edit

Once a Module (device) has been added to the Added list, by selecting the  button you can change the PBUS address if required, it should be noted that each device has to have its own unique address and care should be taken that the address chosen is not being used by another device.

Delete

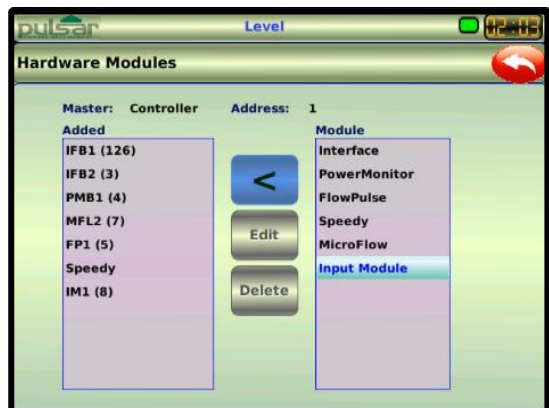
By selecting a device in the Added list and selecting the  button the device will be removed from the system.



Once all of the selected Modbus devices have been correctly selected pressing the  button will prompt a message to appear to save changes made. Clicking 'OK' will save the changes and the Ultimate will re-boot and return you to run mode. Or clicking 'Cancel' will not save any changes made and return you to the menu screen. The event log will indicate any modules that have been added/removed.

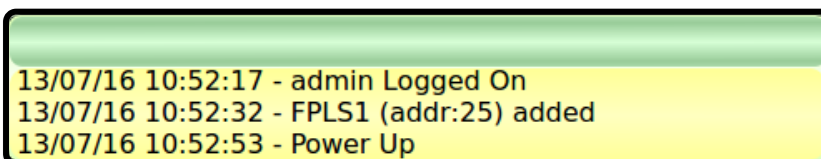

Important Notice

Please refer to '2.9 RS485 Connectivity' of this manual for guidance on which terminals on the Ultimate to connect your device to.

5.3 Log Setup



From the Adv. Config. menu select the icon.

The Log setup menu screen is divided into two sub menus, **Measurement points** and **Echo traces**.



Measurement Points

The Measurement Point screen allows you to clear or save all the logged trends from the measurement points programmed in the controller.

Log Interval

Determines the interval rate in minutes at which data will be logged from all the programmed measurement points. This interval also applies to the data seen on the Trend View information screen during run mode.

Clear Logs

You can also clear the logs by pressing the  button at the top of the Meas. Points screen.

On selecting Clear Logs, you will be prompted to select which logs you want to clear by selecting the check box next to each log location.

Event Log – will clear all log events stored in memory.

Trending Log – will clear all trending information as seen in Trend View

Performance Logs – will clear all Performance logged information as stored under Asset Management

Trace Logs – will clear all trace log information

Camera Logs – will clear all Camera log information



Save Logs

You can also save the logs to an external SD Card by pressing the  button at the top of the Meas. Points screen.

On selecting Save, you will be prompted to select which logs you want to back up to the SD card, by selecting the check box next to each log location.

Event Log – will save all log events stored in memory.

Trending Log – will save all trending information as seen in Trend View

Performance Logs – will save all Performance logged information as stored under Asset Management

Trace Logs – will save trace information onto the SD card.

Camera Logs – will save any camera pictures onto the SD card.



Once you have saved the information to the SD card you can then remove it from the Ultimate and view the information in CSV format. Insert your SD card into your PC and open the folder **Controller** and select the log file

you wish to view. For example: Trending logs will appear in the folder as  Trending-31oct2016-113919

Echo Traces

The echo traces screen allows you to enable the logging of transducer traces when certain conditions are encountered according to the setup of the options detailed below.

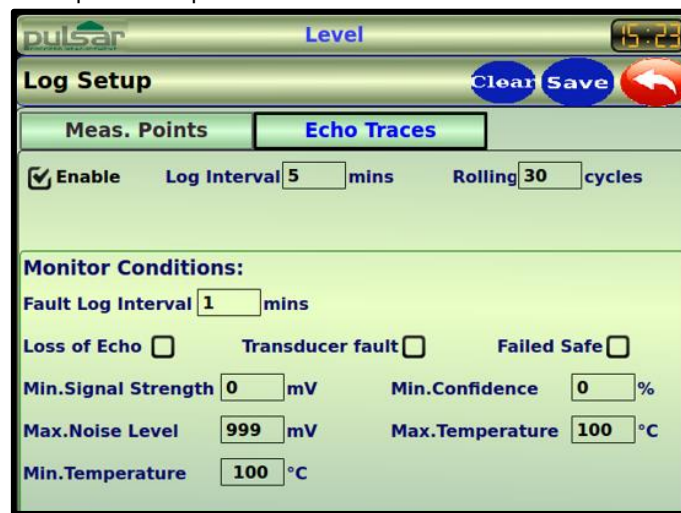

Enable

Determines whether logging of echo traces is enabled or not.

Log interval

This determines the amount of time in minutes, between each log interval.

Rolling period

Determines how many logs are recorded in a set time (in minutes), e.g. if a log interval is set at 5 minutes and the rolling period set at 30 minutes then you would expect to see 6 entries every 30 minutes.

Monitor conditions

Fault Log Interval

Under a fault condition the time (entered in seconds) will determine how often the unit logs the appropriate fault occurrence.

Loss of Echo

When enabled any occurrence of a LOE condition will be recorded, at the intervals set in the fault log interval.

Transducer fault

When enabled any occurrence of a Transducer Fault condition will be recorded, at the intervals set in the fault log interval.

Failed safe

When enabled any occurrence of a Failed Safe condition will be recorded, at the intervals set in the fault log interval.

Min. signal strength

If the echo being processed reaches the minimum signal strength entered, then the occurrence will be recorded, at the intervals set in the fault log interval.

Max. noise level

If the noise level, on the echo trace being processed, reaches the level entered, then the occurrence will be recorded, at the intervals set in the fault log interval.

Min. temperature

If the temperature, on the echo trace being processed, falls to the level entered, then the occurrence will be recorded, at the intervals set in the fault log interval.

Min. Confidence

If the confidence, on the echo trace being processed, falls to the level entered, then the occurrence will be recorded, at the intervals set in the fault log interval.

Max. temperature

If the temperature, on the echo trace being processed, rises to the level entered, then the occurrence will be recorded, at the intervals set in the fault log interval.

5.4 Communications



From the Adv. Config. menu select the icon.

This menu allows configuration of digital communications. Access to the different menus will may limit depending on the specification of the Controller (Please consult Pulsar, for further information and assistance if required).

If you are using a SIM card to communicate via a modem, please ensure that this is inserted into the unit prior to any programming.

DNP3/WITS Connections

This screen allows you to set up to 10 DNP3WITS connections

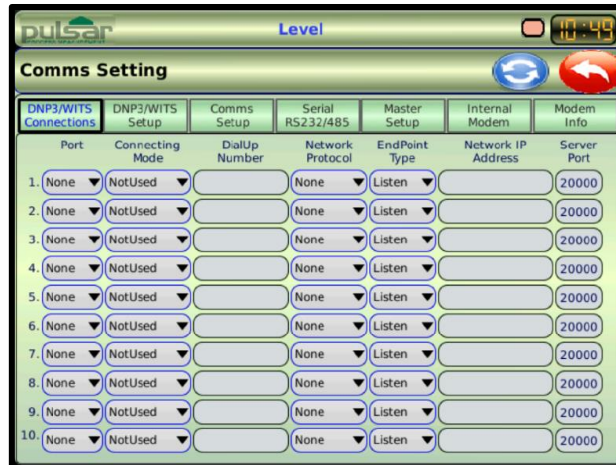

Port

Select the type of connection you are setting up, from the drop-down list available:

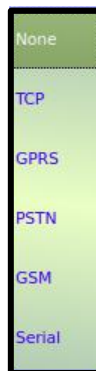

Connecting Mode

Select the mode required from the options available:

CONNECTION MODE	DESCRIPTION
Not Used	No connection will be made.
Permanent	The unit is listening mode waiting for a connection to the Master.
On Demand	If there is an event or repeat interval set, the Ultimate will then connect to the Master.

Dialup Number

Enter the telephone number required to dial out to including the area code if a landline.

Network Protocol

Determines the type of protocol you wish to use for your connection from the list available:

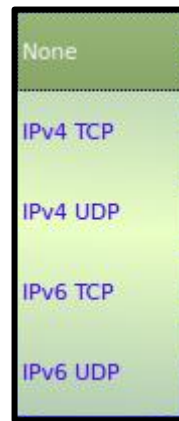

End Point Type

Select the option you require from the dropdown list available:

CONNECTION MODE	DESCRIPTION
Listen	The Controller is waiting for a connection.
Initiate	The Controller will connect to a device.
Dual	The Controller will listen and then initiate a connection.

This is the IP address of the Network that the unit uses to connect and communicate with.

Server Port

Enter the port number of the remote device, to allow the controller to communicate with it.

DNP3/WITS Setup

This screen is used to set the connection parameters For the **DNP3/WITS** protocol.

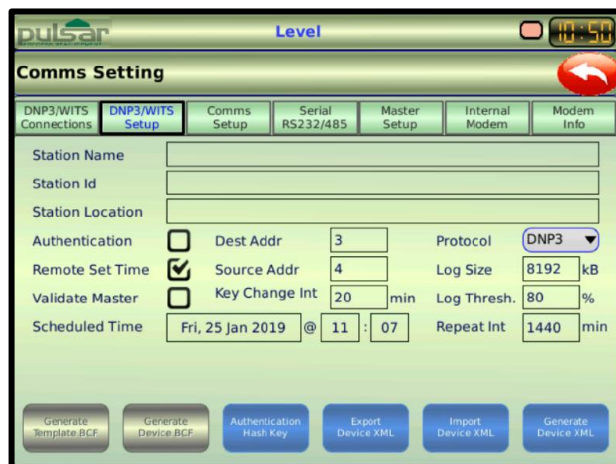

Station Name

This can be used to enter the name of the Station communicating via DNP3/WITS.

Station Id

This is used to enter your unique stations ID.

Station Location

This is used to enter the name of the station’s location.

Authentication

Enabling this option will allow the encryption of all data that is sent to and from the controller.

Remote set time

Enabling this option allows the DNP to set the controller’s time remotely from the master.

Validate master

Security feature that validates the master address and prevents any individual ‘hacking’ into the unit.

Destination Address

This is the Master's DNP3 address.

Source Address

This is the Controllers DNP3 address.

Key change interval

This is the amount of time, in minutes, that the security authorisation key will change to prevent any individual from 'hacking' into the system.

Scheduled Time

Sets the day, date and time when there is to be a 'dial in' to the Controller.

Repeat Interval

This sets the time, in hours, that you can repeat the dial in process i.e., for four times a day you would set the repeat interval to 8 hours.

Generate Template BCF (Bulk Configuration File)

The  button allows a similar process to that of the Generate Device BCF, except initialisation files so that an outstation can keep its unique serial number, IP address, DNP3 address etc.

Generate Device BCF

This  is a zipped file of the Ultimate database, the RTU points list, and several initialisation files. This allows an Ultimate to be cloned or completely configured.

Authentication Hash Key

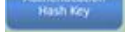
The  button is used to authenticate a user against a unique key which is generated by the Pulsar xml configurator software. This is where a unique key is obtained from the WITS master and encoded again to give to the installer to input to the RTU

Exporting DNP3 XML

Pressing the  button will allow you to export your DNP3 configuration to an SD Card in XML format, and using Pulsar's 'DNP3 Config. PC Software', you can view, make changes and save the setup or insert into another controller.

Importing DNP3 XML

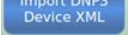
Pressing the  button will allow you to import a DNP3 configuration file from an SD Card. Select the file you wish to import and press '**Import**'. Return to run mode for the changes to take place.

Generate a WITS BCF Package

Pressing the  button will allow you to 'backup' your current WITS profile information to SD card.

Ultimate Comms Setup

Depending on the communications specification of the controller, select the protocol that will be used for digital communications.

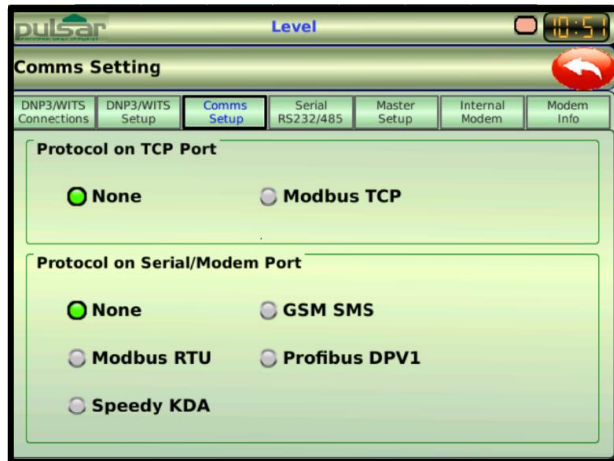

Protocol on TCP Port (Ethernet)

Modbus TCP is available as standard on all Ultimate controllers. If the controller has DNP3/WITS protocols, these are automatically enabled on the ethernet port.

Protocol on serial/modem port

CONNECTION MODE	DESCRIPTION
Unsigned Integer	16-bit values from 0 - 65335
Signed Integer	16-bit values from -32768 to +32768.
Float Modicon	32-bit floating-point values. This is an order in which the most significant value in the sequence is stored first. (big endian)
Float IEEE	32-bit floating-point values. This is an order in which the least significant value in the sequence is stored first. (little Endian byte swapped)
Unsigned Integer	16-bit values from 0 - 65335

Serial RS232/RS485

This screen allows you to setup a Modbus, Profibus, KDA or RS232/RS485 communication connection through the RS232 or RS485 terminals on the Controller.

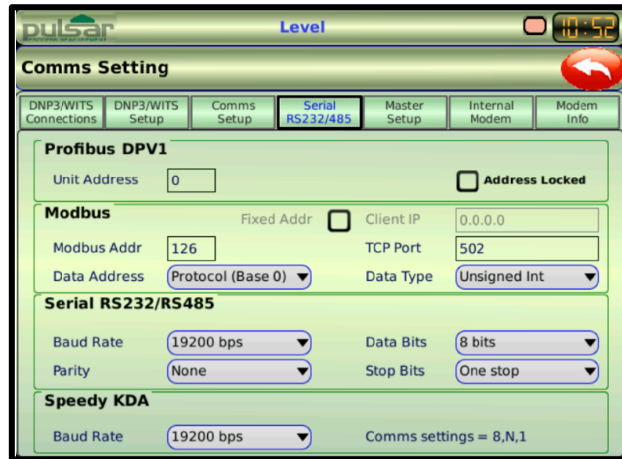

Profibus DPV1

Profibus is a vendor independent, open field bus standard for a wide range of applications in manufacturing, process and building automation. Vendor independence and openness are guaranteed by the Profibus standard EN50170. With Profibus, devices from different manufacturers can intercommunicate.

Unit Address

Used to set the Slave address of the Ultimate controller

Address Locked

Select this box to lock the unit's address so it cannot be changed by a Profibus master.

Modbus

Modbus defines a digital communication network to have only one MASTER and one or more SLAVE devices. Either a single or multi-drop network is possible. A typical transaction of information will consist of a request sent from the master followed by a response from the slave.

Modbus Address

Used to set the Slave address of the Ultimate controller

Data Address

This allows you to choose the base index of (0 or 1) when connecting to a specific PLC.

Fixed address

When checked, will only allow communication with a master from a specified client IP address.

Client IP

IP address of the specified client (master)

TCP Port

This is used to enter the TCP port number for Modbus TCP comms (default = 502).

Data Type

CONNECTION MODE	DESCRIPTION
Unsigned Integer	16-bit values from 0 - 65335
Signed Integer	16-bit values from -32768 to +32768.
Float Modicon	32-bit floating-point values. This is an order in which the most significant value in the sequence is stored first. (big endian)
Float IEEE	32-bit floating-point values. This is an order in which the least significant value in the sequence is stored first. (little Endian byte swapped)

Serial RS232/RS485

Set the bus parameters for communication over RS232 or RS485.

Baud Rate

Sets the communication data rate.

Parity

Determines the Parity of the device, choices are: None, Odd, Even, Mark or Space. The parity bit is used in parity error checking to search for errors that may occur during data transmission or storage on a mechanism.

Data bits

Sets the number of data bits in the communication frame.

Stop bits

Sets the number of stop bits for the communication frame

Speedy KDA

Bus parameters for devices using the Speedy KDA communications protocol.

Baud rate

Sets the speed of the digital communications interface to match that of the device it is communicating with.

Master Setup

Ultimate can be used as a Modbus TCP master to communicate with specified slave devices (GSM modems etc.) and retrieve status information to pass on via communications protocols.



Timeout

This sets the connection timeout in milliseconds.

Modbus Address

Set the Modbus address of the slave device.

Data Address

This allows you to choose the base index of (0 or 1) when connecting to a specific PLC.

Type

Select the type of device to communicate with (at present only CASE is selectable).

Client IP

Set the IP address of the slave device.

TCP Port

Enter the TCP port number for comms (default = 502).

Internal Modem

This screen sets the connection parameters for the internal modem (if available).

The screenshot shows the 'Comms Setting' screen for an internal modem. The screen is titled 'pulsar Level' and has a digital clock showing '10:53'. The 'Internal Modem' tab is selected. The screen is divided into two main sections: 'GPRS' and 'Connection Preferences'.

GPRS Section:

- APN: [Text Input Field]
- User name: [Text Input Field]
- Password: [Text Input Field]
- Ping IP: [Text Input Field]

Connection Preferences Section:

- Preferred Network: [Auto] (Dropdown)
- Preferred Operator: [Auto] (Dropdown)
- Connection TimeOut: [3] mins
- Redial Retry: [3]
- Link Status Interval: [0] mins
- Disconnect Idle Time: [60] mins
- Redial Interval: [2] mins
- Listening TimeOut: [1] hours

GPRS

APN

This is the name of the gateway that the controller uses between the GPRS, or mobile network and another computer network, most commonly the Internet.

User Name

Enter a User Name, along with the user password to allow access to the unit's online network.

Password

Enter the user password to allow access to the unit's online network.

Ping IP

This is used when scanning networks, the IP address is 'pinged' to assess the connection.

Connection Preferences

Preferred Network

Select the preferred communications operator from the drop-down list. If the selection is left at '**Auto**', then the Ultimate will automatically attempt a connection through the list of operators:

- Vodafone
- O2
- Three
- EE
- Orange
- T-Mobile

Connection Timeout

This is the time allowed in minutes for the modem to obtain a valid connection to the network.

Redial Retry

If the connection has timed out, this determines the number of times the connection will be attempted

Link Status Interval

When connected via DNP3/WITS, if there has been no data transfer for the duration of the Link Status Interval, the RTU will send a DNP3 Null pulse to assess the connection status.

Disconnect Idle Time

When connected via DNP3/WITS, if there has been no communication for the duration of the Disconnect Idle Time, the current connection will be closed, and the connection process restarted.

Redial Interval

Sets the time interval between a failed connection attempt and a connection retry.

Listening Time Out

When using DNP3/WITS, if there has been no DNP3 data transfer for the duration of the Listening Timeout, the RTU and modem will be restarted.

Modem Info

This screen allows you to view the information from the modem that is connected to the unit when communicating via GPRS, PSTN, GSM or DNP3.

For GPRS, when there is no Server IP, the unit will be in 'listening mode' awaiting a connection from an external source (master).

When connected 'Connection status – ONLINE' will appear. If after 2 minutes, there is no communication the unit will auto disconnect.



Scans the network for preferred operator and network provider. After the redial attempts is reached it reverts to automatic selection.



Touch this button if a condition is not met for an automatic dial-out. Pressing this will force the unit to dial out to the Master



Touching this button will force the modem to disconnect. The next connection time appears as set up in **interval time**.

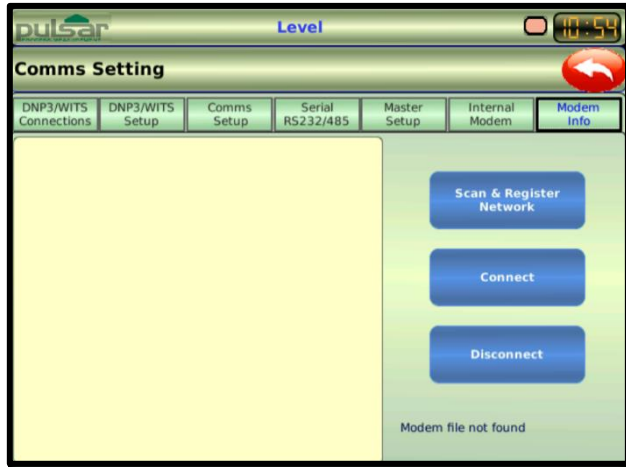

When a connection is made, the information on the screen will look similar to the picture opposite.

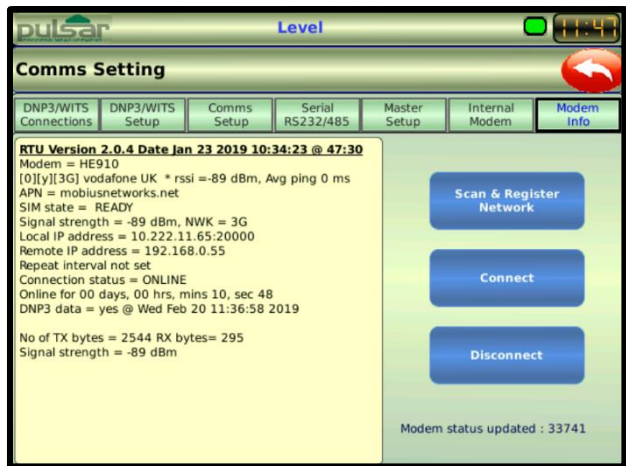

5.5 Networking

From the Adv. Config. menu select the  icon.

Ultimate has an Ethernet socket which can be used for Modbus TCP and DNP3/WITS communication over TCP/IP, and also for viewing the application data and information via web pages hosted by the internal webserver. The network page provides standard IP network configuration parameters.

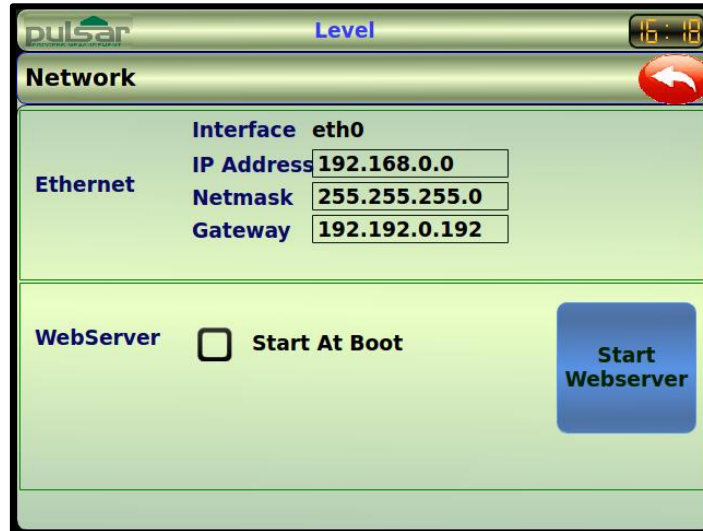

Ethernet

This screen is used to view and enter the Ethernet connections address information.

Interface

This is a set value and cannot be changed, and displays the name of the interface

IP Address

Shows the IP address of the controller's network interface. The default address is unique to the controller but can be changed if desired.

Netmask

Netmasks are used to divide computer networks. For standard controller configuration, the Netmask should be left as default 255.255.255.0 so any local computer address can connect to the Ultimate controller.

Gateway

Network address of the gateway used to connect to other networks. For Ultimate Controller, this should be left at its default value of 192.168.0.254

Webservice

Normally the internal webserver starts when the system boots. The running status can be viewed from the  hotkey in run mode.

A local wired connection can be made with a standard Ethernet cable. The web pages can be viewed by entering the IP Address of the Ultimate into your web browser's address bar.

(You may need to configure your computer's IP address when connecting via this method)

Should it be necessary the webserver can be forced to start by selecting the  button.

5.6 CCTV camera



From the Adv. Config. menu select the icon.

The Pulsar CCTV camera allows a near real time visual check on the application process, or application site via still images taken at regular intervals. The camera module features LED illumination so can provide images in areas of low light. Connection is made via the dedicated RS485 camera port on the Ultimate hardware.



Type

Modbus

Address

Set this to the Modbus address of the Pulsar camera. The Pulsar Cameras have a default address of 125.

Scan Time

Determines the rate at which the Ultimate requests an image from the camera.

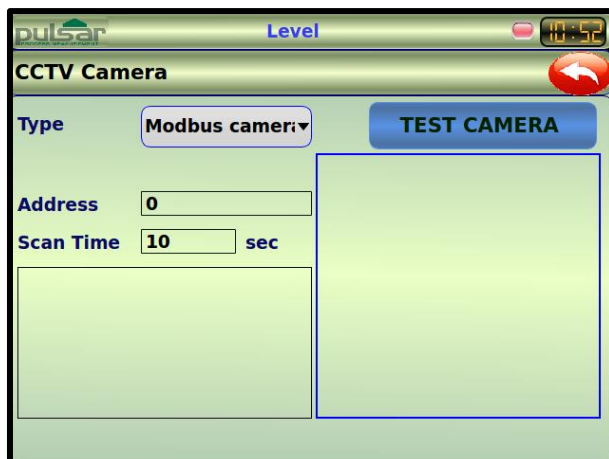

IP Camera

IP Address

Set this to the IP address of the camera.

Scan Time

Determines the rate at which the Ultimate requests an image from the camera.

Port

Set the network port number for the camera communications

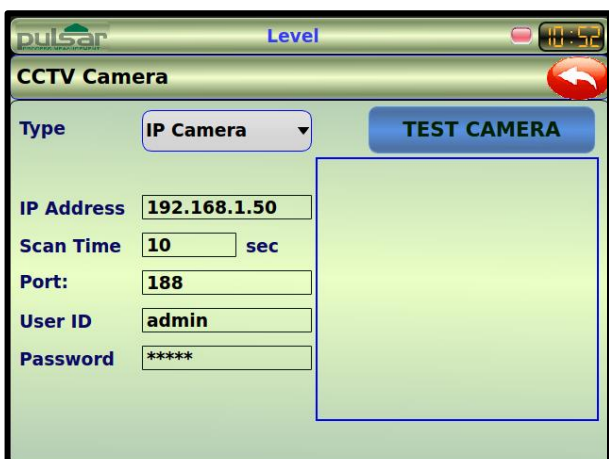

User ID

If the IP camera requires a user ID, it should be entered here

Password

If the IP camera requires a user password, it should be entered here

Once the camera type has been selected and communication requirements completed, the camera can be tested by selecting the **TEST CAMERA** button. Images from the camera will be shown in the blue frame, updating at the chosen interval time.

The camera will continue to take pictures until the **STOP** button on the screen is selected.

During Run Mode you can view the camera pictures by touching the top of the screen which then brings the hotkey menu into view. Next, select the camera icon in the hotkey menu and you will now see the pictures being taken by the camera. Touching the camera icon again will dismiss this feed so that you can use the other features available on the main display or enter program mode.

5.7 User accounts

From the Adv. Config. menu select the  icon.

The Ultimate Controller uses a user account system where custom usernames and passcodes can be created. Using accounts provides a method of restricting access to certain users, and the username will be logged in the event log each time program mode is accessed. User accounts can only be created or deleted when in program mode as the administrator.

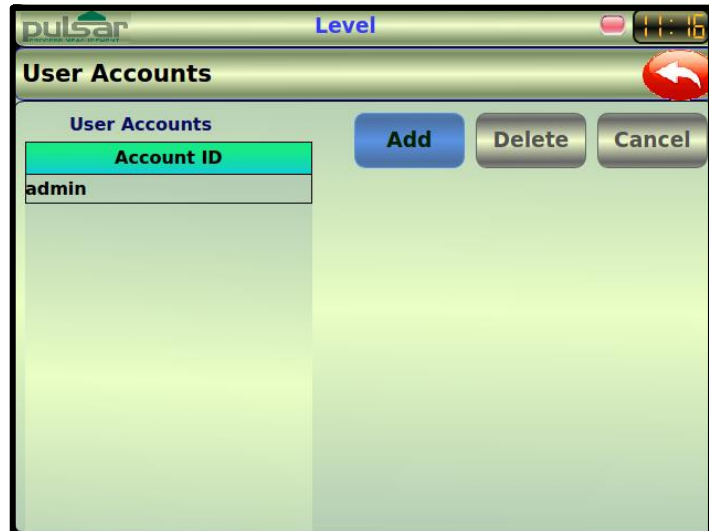

Adding User accounts

Press **Add** and complete the new account registration boxes

User ID	<input type="text"/>
Passcode	<input type="text"/>
Repeat Passcode	<input type="text"/>

then press **Save**

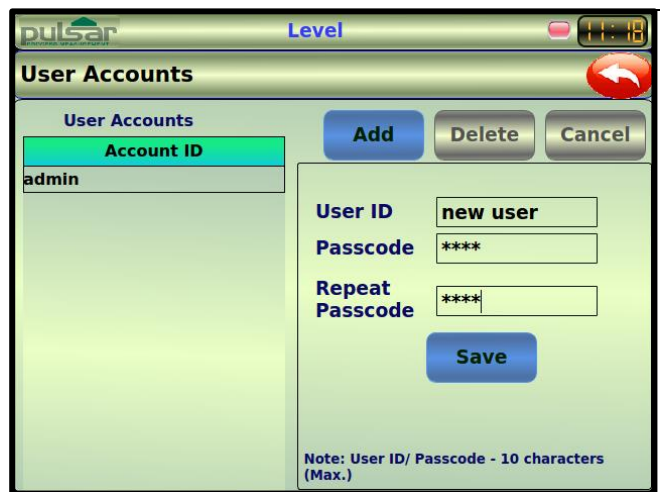

Changing User Accounts

Admin

It is prudent at this stage to for the administrator to change the admin passcode to keep the administrator rights secure.

To change the passcode, simply touch the **admin** entry in the Account ID table, and then amend the Passcode boxes to the required passcode and then press **Save**

User

When an individual user is logged in they will be restricted to being able to make changes to their own user account only.

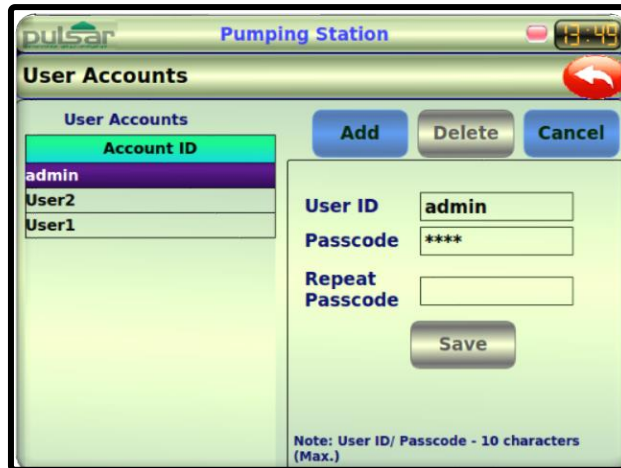

Deleting User accounts

Admin

To delete a user account, select the account to be deleted from the Account ID column, and select **Delete**

Complete the following confirmation and the selected account will be removed.

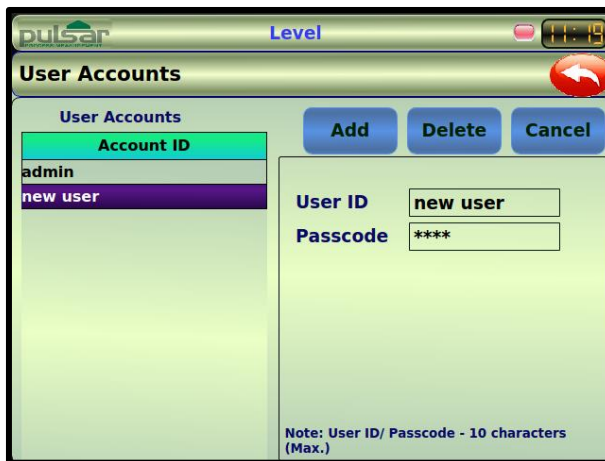

5.8 General settings

From the Adv. Config. menu select the  icon.

This menu allows for the setup of the general settings common to all aspects of the controller.



Date/Time

From this menu, changes can be made to the Time and Date and determine whether DST is to be used or not.

Time can be changed via the Set Time dropdown boxes

Date can be selected from the scrolling calendar

DST is enabled by selecting the DST check box and setting time difference, DST Start and End date

Once changes are completed select  to save the changes.

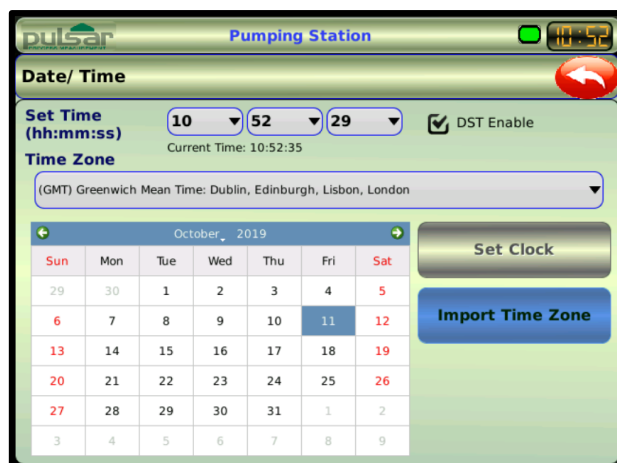

Time Zone

A regional time zone can be selected from the drop-down list.

Import Time Zone

If required, time zone files can be imported from the SD card.

Regional Options

From this menu changes can be made cater for specific regional settings such as language and date format.

Language can be selected from the dropdown menu current choices are:

- English (United Kingdom)

Date Format can be selected from the dropdown menu from the following choices:

- mmddyy
- ddmmyy (default)
- yymmdd



Changing any of these options will display a message box explaining that the Event/Trending logs will be cleared, pressing 'OK' will continue with the change or by pressing 'Cancel' no changes will be made and no logs will be deleted.

Display Control

This menu allows changes to be made to the way the display functions.

Full details of the options and their function are given below.



Program Mode Timeout

When in Program Mode, this is the amount of time, in minutes, before the unit will automatically return to 'run mode' if it does not detect any screen touches.

Screen Saver Enable

This option allows you to choose whether you wish for the screensaver to be activated upon the screen saver timeout limit being reached.

Screen Saver Timeout

The amount of time in minutes after the screen was last touched in run mode before the screen will show the screensaver.

Screen Brightness

Adjusts the screens brightness to one that suits the user.

Enable Beep sound

Enables/Disables the beep/click sound that acknowledges a screen press.

Trace Screen Timeout

When on the Echo Trace screen, this is the amount of time, in minutes, before the unit will return to 'run mode' if it does not detect any screen touches

Power Control

This menu allows you to view and change the settings of functions that monitor and make the user aware when there has been a power failure associated with the controller.

If enabled '**Yes**', then in the event of a power failure occurring it will be **recorded** in the **events log**, which can be viewed at the bottom of the main screen when in run mode.

Power Fail Report will record both AC or DC power fail events.

Report Mains Failed will only report failures of mains power.

Mains Fail Disable Control when a fail condition occurs the unit can inhibit all digital output functions

Report DC Failed will only report failures of DC power.



5.9 Maintenance



From the Adv. Config. menu select the icon.

This feature allows the control and alarm outputs of the controller to be inhibited for purposes such as site maintenance or commissioning. The feature can be operated from run mode via Hot Key button, or via a digital input. This is so maintenance can be carried out on the application without an external source switching gear on.

Maintenance

This screen allows you to setup the controller for allowing maintenance to be carried out on an application i.e., a well or tank.

Section	Parameter	Value	Unit
Maintenance	Enable	Yes	
	Timeout	160	mins
	Timeout Alarm	No	
Smart Alarms	Enable	No	
	Jeopardy Time	30	mins
Wet Weather Profile	Enable	No	
	TimeOut	24	hrs

Enable

Determines whether the maintenance mode is enabled or not.

Timeout

When in Maintenance mode, the Ultimate controller will revert to run mode on expiry of this time period.

Timeout Alarm

With this enabled and in run mode, in the event the maintenance mode expires as set in **Timeout**. The controller's audible alarm will sound. It also enables remote events such as SCADA events to be sent.

Disable Controls

This is defaulted to disable all controls, i.e., all digital and analogue output from normal operation. It will still read inputs, but it will not initiate anything to run.

Smart Alarms

Enable

Determines whether the Smart Alarm mode is enabled or not.

Jeopardy Time

If the smart alarm condition remains in a normal state and unchanged, after the jeopardy timer (set in minutes) has elapsed then the pump station overload alarm register is generated.

Wet Weather Profile

Enable

Determines whether the Wet weather profile is enabled or not.

Time Out

If you are in Wet weather for longer than this period, a warning is displayed and relayed via telemetry.

CHAPTER 6 SYSTEM

Enter Program Mode and enter  and the System Menu will be displayed.

The System menu system is used to test the Ultimate's Hardware, Default the unit, backup and restore user profiles and to upgrade the firmware. Some of these features, Firmware Upgrade, Hard Default and Backup Profile are only available when accessed by an Admin/Service passcode.



6.1 Hardware Test

From the System menu select 

The Hardware test menu system you will be able to test the Ultimate's relays, Digital inputs, mA outputs, and the mA inputs.

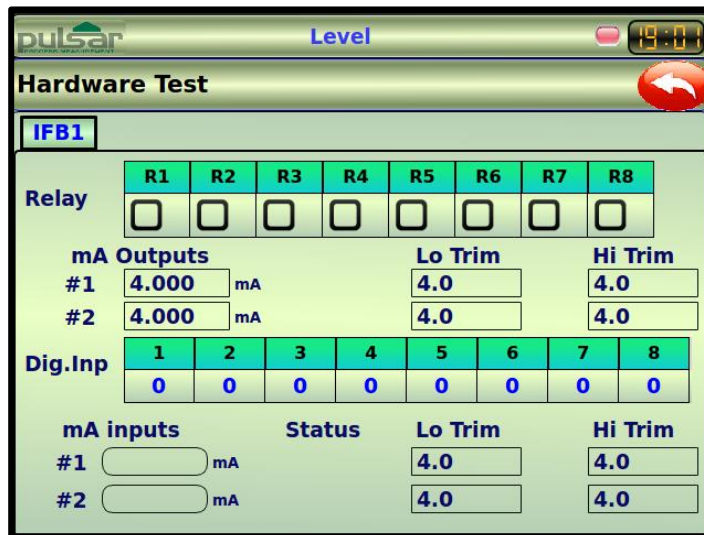

Relays

To check the relays are working correctly simply click on the box relating to the relay you want to test, for example if you want to check Relay 5 is working select the box underneath R5, once you have clicked selected the box a tick will appear and the relay will change its state.

mA Outputs

This parameter will allow you to force a specified current on the mA output, in order to test the equipment that it is connected to, and to make sure the unit is working correctly. The figure you enter will be generated by the mA output. (#1 relates to mA output 1 and #2 relates to mA output 2)

mA Outputs Lo Trim

If the device you are connected to is not calibrated, and not showing the correct low value (reading), then you can trim it using this parameter.

mA Outputs Hi Trim

If the device you are connected to is not calibrated, and not showing the correct high value (reading), then you can trim it using this parameter.

Dig. Input

This will show you what digital inputs are receiving an input/signal. When a signal is present at the digital input the number 1 will be present in the corresponding digital input box.

mA Input

This parameter will allow you to test the mA input, by injecting a known mA signal from an external source, in order to check the unit is working correctly and as expected.

mA Input Lo Trim

This parameter allows you to "calibrate" the controller to the Low mA Input from the device being used. If the expected low value, from the device connected to the mA Input, is not displayed, then you can trim it using this parameter.

mA Input Hi Trim

This parameter allows you to "calibrate" the controller to the High mA Input from the device being used. If the expected high value, from the device connected to the mA Input, is not displayed, then you can trim it using this parameter.

6.2 Soft Default

From the System menu select 

A soft default will delete and return, all user application settings, to their factory default settings, it is recommended that a 'Backup Profile' be taken before proceeding in case it is needed to 'restore' the controller to its original settings.

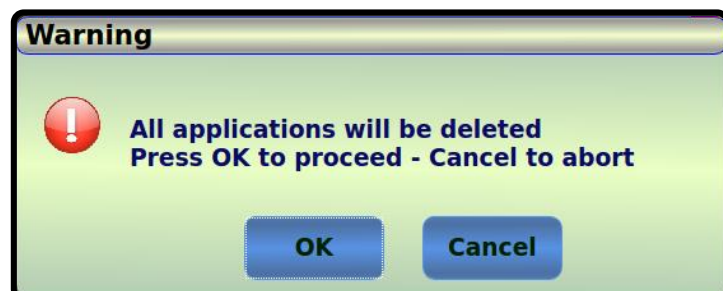

6.3 Setup Profiles

From the System menu select 

Entering the menu system you will be able to choose between setting up a local or remote profile.



Local Profile

Used to restore a backup of all the unit's parameters, for example if alterations are made to the parameters that do not work as intended, then the backup set can be restored into the unit. Select which memory device to use, Internal or External (under flap on left hand side of controller).

To delete all profiles that are currently saved on the

SD card selected then select .

To delete a specific profile, simply touch the profile

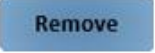
you want to delete and then select .

To restore a profile simply click on the profile you

want to restore then select .



Remote Profile

This is used to restore profiles that have been created by the user remotely on a PC which has individual parameter changes and then stored onto an SD card. For a full list of parameters and their values that can be changed refer to **Appendix-B Ultimate Static Parameters**.

Inserting the SD card into the Ultimate and entering the Remote profiles screen (as shown below) will allow you to select the profile to load (from a selection of 1 – 10).

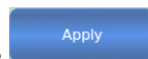
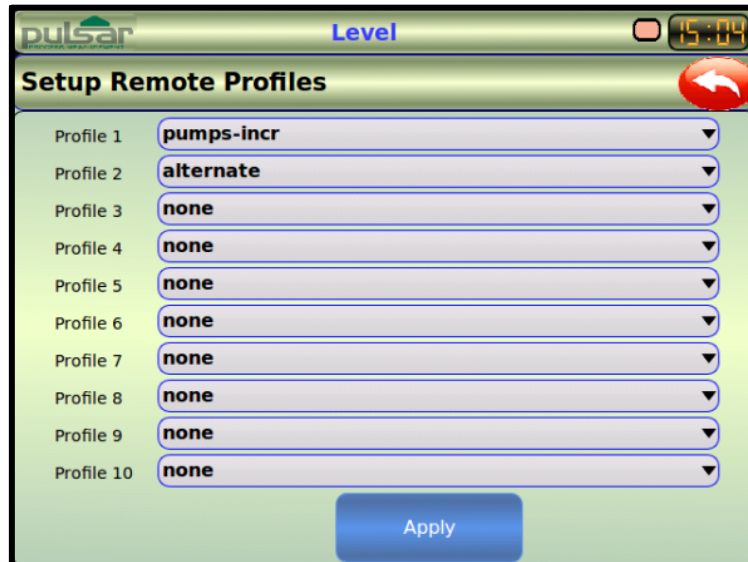

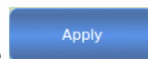
When the profiles have been chosen, select the  button to apply the profile. A message will appear to make sure that you wish to import the profiles. Select OK to continue or Cancel to return to the remote profile screen.

The profile can then be remotely activated by Modbus, RTU or the webserver using the static parameter *** to turn on remote profiles and then parameter *** to activate profile(s). Upon activation of the profile the event log will be updated.

Creating a remote profile

The profiles are created on a PC in text format (Wordpad for example) and then stored with the extension .mac, and then copied to the folder 'Profiles' or on a visible partition on a SD card.

Example:

On your PC, open WordPad (or any other text format software). Starting with a capital 'P', enter the parameter number (refer to **Appendix-B Ultimate Static Parameters**) followed by '=' and the new value you wish to change that parameter to.

For example: To change the program mode timeout, parameter 300, enter the text into your document as shown in the picture opposite.

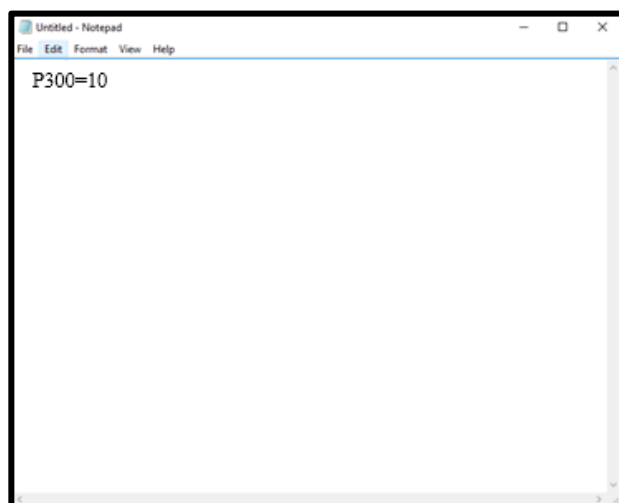

Once you have entered all of the parameter changes required into your text document, save the file onto your SD card, in the Profiles folder and using " " at the beginning and end of the name. See example screenshot below:

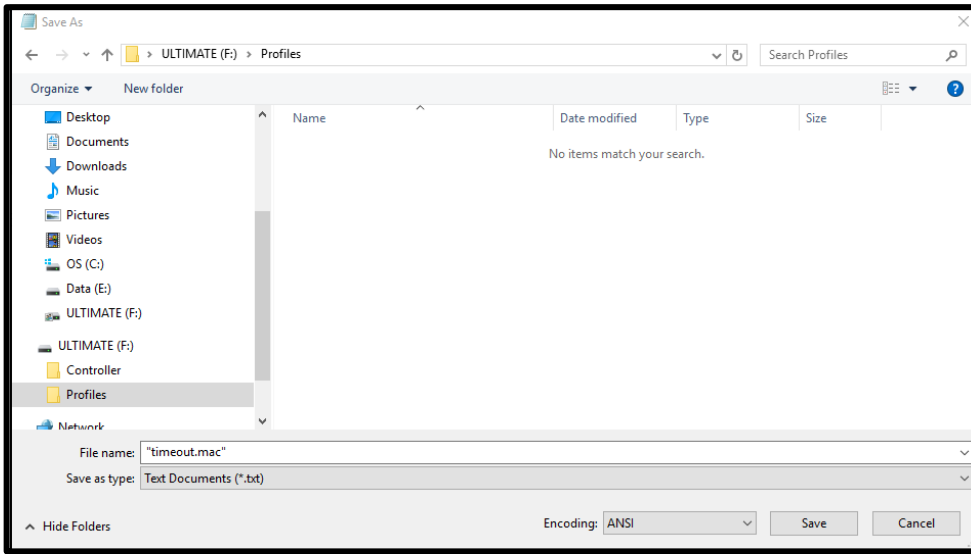

Once the file has been saved onto the SD card, you can then insert it into the Ultimate and upload it onto the unit using the Remote profile command.

6.4 Hardware



From the System menu select

By selecting the Hardware Icon an overview of basic setup information will appear for any hardware connected and assigned to the controller and will include **Interface board, Input Interface, Powermonitor, Microflow and Flow Pulse**.

Use the tree menu on the right to select the hardware you wish to view.

Interface Board (IFB)

When selected the Interface overview will provide information on the IFB and its address on the PBUS and shows basic setup information on the its **transducer(s), Relays, mA In/out and the Digital input** settings.

The screenshot shows the 'Hardware overview' window for 'IFB 1 (Addr:126)'. The interface includes a tree menu on the left with options for IFB 1, PWR 1, MFLO 1, and FP 1. The main area displays the following data:

TDR		Description
1	IFB 6, Empty: 6.000m, Span: 5.700m	
2	none, Empty: 6.000m, Span: 5.700m	

Relay	Type	Description
1	Pump	FDA , PumpGroup 1,setpoint 1: 2.000 m, setpoint 2: 1.000 m
2	Control	Differential
3	Alarm	Meas.Point Hi
4	Misc	Totaliser
5	None	None
6	None	None
7	None	None
8	None	None

mA In	Description
1	mA1 In, Level, (0 mA ~ 20 mA)
2	mA2 In, Level, (0 mA ~ 20 mA)

mAOU	Description
1	mA1 Out, (0 mA ~ 20 mA) , low: 4 mA , high: 20 mA
2	mA2 Out, (0 mA ~ 20 mA) , low: 4 mA , high: 20 mA

DIN	Description
1	DIN 01, None
2	DIN 02, None
3	DIN 03, None
4	DIN 04, None
5	DIN 05, None
6	DIN 06, None
7	DIN 07, None
8	DIN 08, None

Power Monitor (PWR)

When selected the Power Monitor overview will provide information on the PWR and its address on the PBUS and shows basic setup information including the **Max Volts, Max Current** and information on the **IRT** settings.

The screenshot shows the 'Hardware overview' window for 'PWR 1 (Addr:3)'. The interface includes a tree menu on the left with options for IFB 1, PWR 1, MFLO 1, and FP 1. The main area displays the following data:

Description	
Protocol	: Modbus RTU
Max. Volts	: 600.00
Max. Current	: 208.00
Turn Ratio	: 100.00
IRT Enable	: Yes
IRT Interval	: 168.00 hours

FlowPulse (FP)

When selected the FlowPulse overview will provide information on the FP and its address on the PBUS and shows basic setup information including Sensitivity, **Damping** and **Track Method** settings.

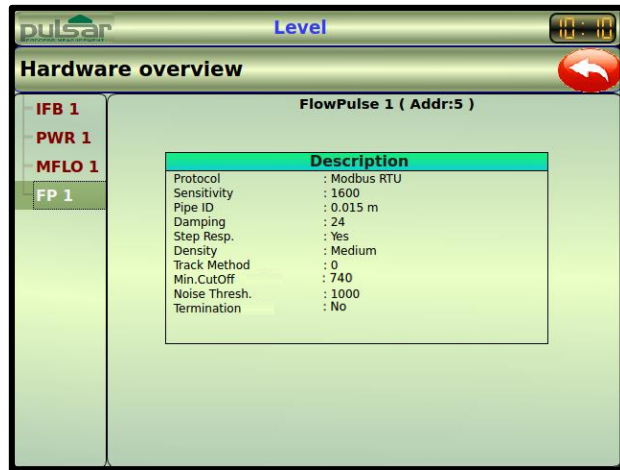

MicroFlow (MFLO)

When selected the MicroFlow overview will provide information on the MFLO and its address on the PBUS and shows basic setup information including **Gain**, **Damping** and **Response** settings.

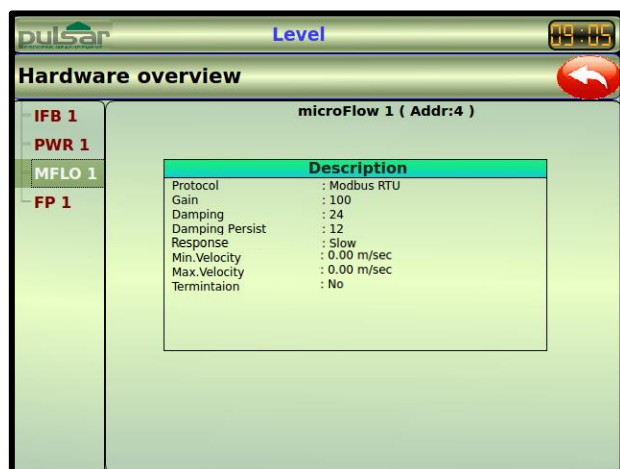

6.5 Firmware Upgrade

From the System menu select



From here you can upgrade the Ultimate's Firmware. The unit can be upgraded Via the SD card or USB port. For further information and support please contact Pulsar for further information and support.

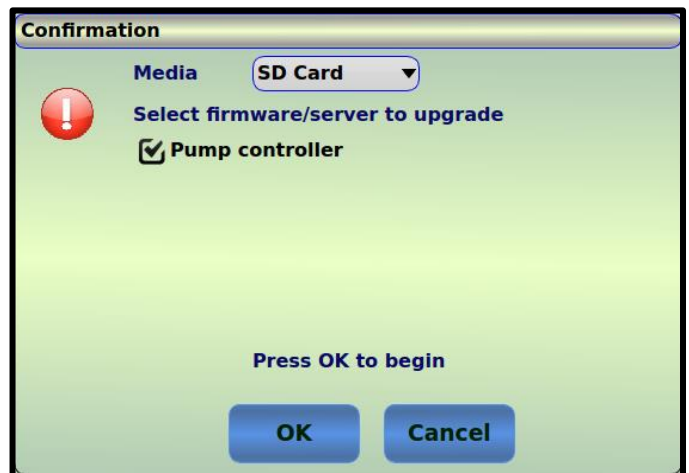

6.6 Hard Default

From the System menu select



A hard default will return the unit to its factory reset condition and will delete, all user application data including any service changes and will remove all hardware profiles, to their factory default settings, it is recommended that a 'Backup Profile' be taken before proceeding in case it is needed to 'restore' the controller to its original settings.

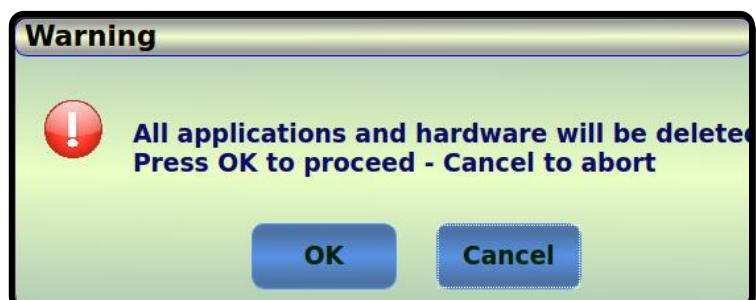

6.7 Backup Profile



From the System menu select

Used to make a backup of all parameters, to ensure a default set is maintained. Should any subsequent alterations made to the parameters not work as intended, then the backup set can be restored into the unit.

When backing up a profile you can select to store the profile in the Ultimate's internal memory or store the profile on a SD card by selecting 'external'.

In order to identify the backup, you can give the profile a Name and a Description.



6.8 Software



From the System menu select

By selecting Software, a list of information will appear which will state the **Firmware Version, Hardware Version, Kernel Version, OS Version, Database Version, Build Version, Task manager, Web Server, Media Server, Serial Number, Interface(s), Modules added** and when the next **Service is Due**

These details are for information only and may be required by Pulsar, when making technical enquiries.

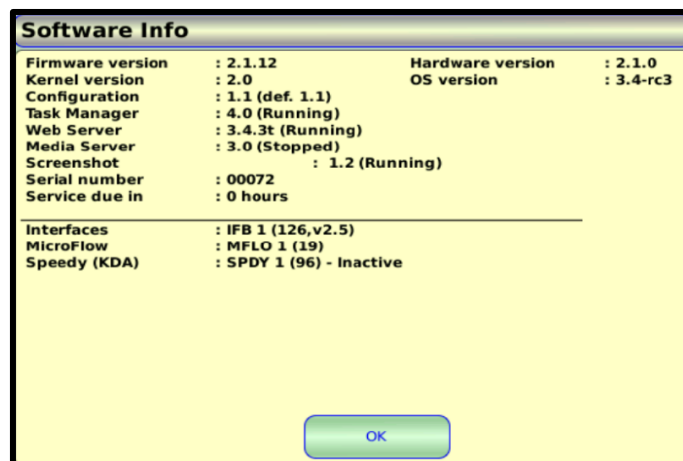

CHAPTER 7 ASSET MANAGEMENT

Enter Program Mode and enter  and the Asset Management Menu will be displayed

The Ultimate controller can assist in efficiently maintaining and servicing station assets by recording and logging all relevant station data and presenting this data in a format that enables informed maintenance decisions to be made. This can lead to considerable cost savings long term by only servicing and maintaining assets that require it rather than because a time has elapsed, and that asset will be serviced regardless of whether maintenance is required.



7.1 Overall Station Data

The data stored/recorded is dependent upon what Modules (devices) are being used and how the controller is configured for certain functions.

e.g., to record data related to power usage a power monitor(s) will be required and to record data related to pumped volume the controller will need to be configured for pumped volume.

The Station Info contains data that is currently stored/recorded by your Ultimate controller and their values. Using the side bar on the left allows you to scroll up and down, through the list of recorded information.

The values that are shown on this screen are **read only** and only an administrator can clear the values that are shown by pressing the 'Clear' button or by completing a 'Hard Default' of the unit.

Parameter	Value
Num pump starts this week	0
Num pump starts last week	0
Total pump runtime (min)	0.00
Total pump runtime this week (min)	0.00
Total pump runtime last week (min)	0.00
Total pumped volume (m3)	0.00
Pumped sys.totaliser (m3*1)	0.00
Pumped res.totaliser (m3*1)	0.00
Pumped daily totaliser (m3*1)	0.00
Total kWh used	0.00
Num blockage detected	0

7.2 Logged Performance Data

Provides chart views of the historical performance data of the station and pumps. The amount of available data will depend up on the sensors connected to the system e.g., power monitors, FlowPulse or flow meters etc.

Setup

To determine the total dynamic head required for the Station API data, the rising main pressure needs to be considered. This menu screen provides parameters for the pressure, which can either be measured via a pressure sensor (mA input sensor) or set as a fixed value.

This information will then be logged at specific intervals as set in **Log Display Interval**.

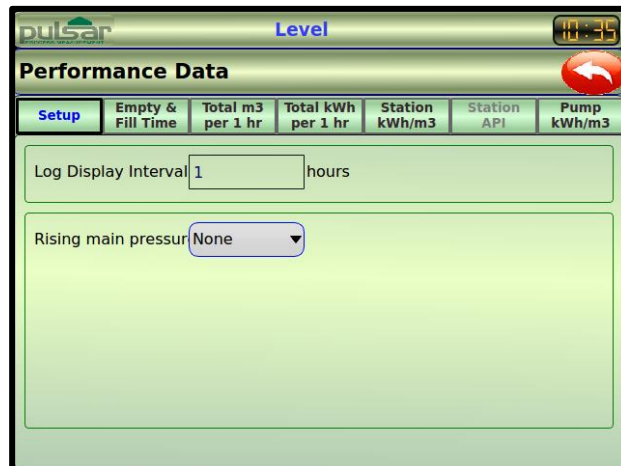

Log Display Interval

This determines the amount of time in hours, between each log interval.

Rising Main Pressure

Determine the method to be used to measure the rising main pressure.

Sensor Height

Determines the vertical height of the pressure sensor from the center of the discharge port of the pump. (sensor height should only be shown when set to Measured).

Estimated pressure

Sets the estimated pressure in the rising main. It may be possible to determine this from sewer network and civil engineering drawings.

Sensor

Selects which **Pressure** measurement point to use for the rising main pressure. The list will only show available measurement points.

Relative S.G.

Enter the SG (Specific Gravity) of the liquid to be pumped.

Empty & Fill Time

This screen allows you to view the empty and fill times of the vessel that is programmed into your controller. This will show you in line graph format the average time that it takes for your vessel to fill (indicated by the blue line) and be emptied by the pump(s) (indicated by the red line). This information could be useful to help determine whether a pump or pump(s) are not pumping efficiently as would be expected, or if there are other circumstances that are causing the vessel to be pumped down slower.

This screen gives details of the average empty and fill times of a vessel.

Bottom axis of the graph shows the date and time, where the vertical axis shows the time in seconds. This graph will plot up to 300 records of logging information before pushing the oldest day 'out'.

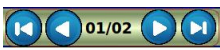
Use  arrows above the graph to scroll through the logged information pages.

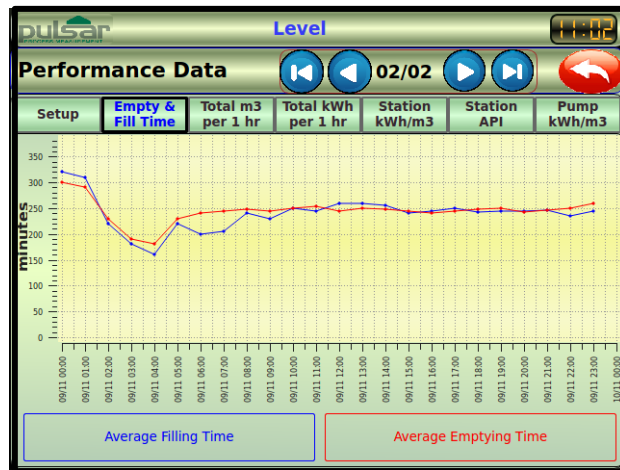

Total m³ per hour(s)

This screen allows you to view the total volume of material that has been pumped from the vessel in cubic meters (m³). This is shown in bar graph format and displays the amount of material in m³ pumped over a time period set in **Log Display Interval** by the pump(s) in the vessel.

This screen gives details of the total amount of material pumped in cubic metres (m³) from the vessel.

Bottom axis of the graph shows the date and time, where the vertical axis shows the quantity in m³. This graph will plot up to 300 records of logging information before pushing the oldest day 'out'.

Use  arrows above the graph to scroll through the logged information pages.

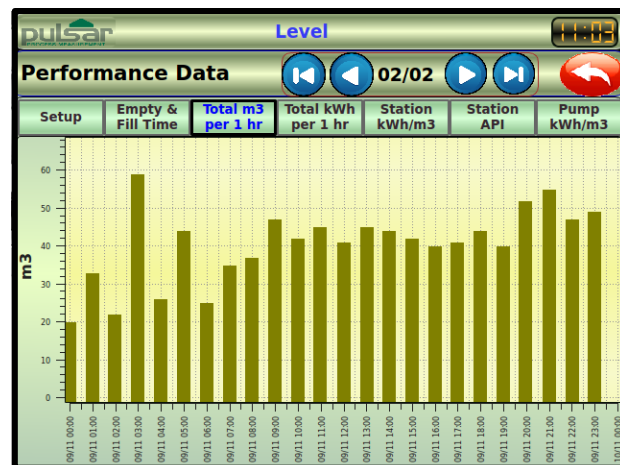

Total kWh per 1 hour

This screen allows you to view the total amount of energy used in kWh in the log interval set in **Log Display Interval**, by the pump(s) to pump the material from the vessel. This information is shown in bar graph format to make it easier to identify the amount of energy used. The information displayed on the screen could help to identify if there are efficiency problems with the pump(s) and they may require maintenance, as they may be using too much energy to do the task they have been programmed to do.

This screen gives details of the total amount of energy used per interval time in kWh by the pump(s) emptying the vessel.

Bottom axis of the graph shows the date and time, where the vertical axis shows the energy used in kWh. This graph will plot up to 300 records of logging information before pushing the oldest day 'out'.

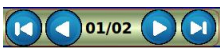
Use  arrows above the graph to scroll through the logged information pages.

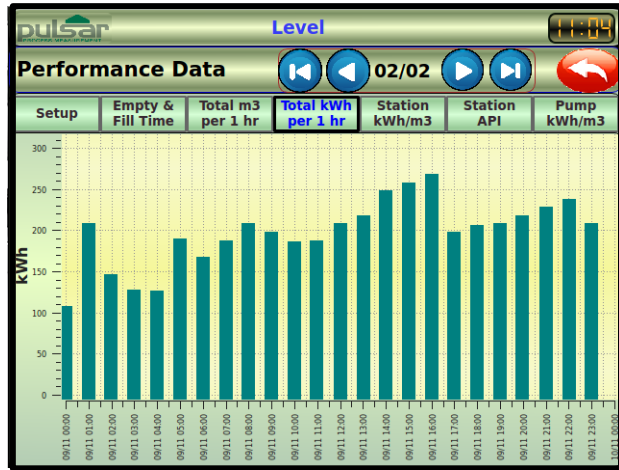

Station kWh/m3

This screen shows the total average amount of energy used by the pump(s) per cubic meter, per log interval time set. The controller does this automatically and places the information in line graph format to make it easier to identify the performance of the pumping application. This information can also be used to help identify a reduction in the efficiency of the pumping application.

This screen gives details of total amount of energy used divided by the volume (m³) in the log interval of the pump(s) emptying the vessel to give you an overall average performance of all pumps.

Bottom axis of the graph shows the date and time, where the vertical axis shows the energy/volume in kWh/m³. This graph will plot up to 300 records of logging information before pushing the oldest day 'out'.

Use  arrows above the graph to scroll through the logged information pages.

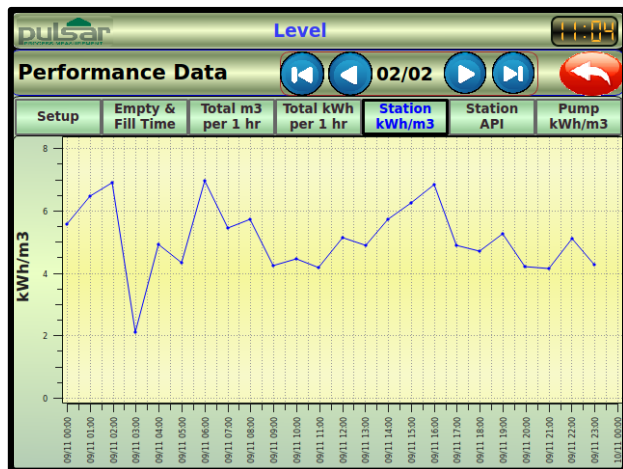

Station API (Assets Performance Index)

When a 'Rising Main Pressure' is selected this screen is then visible and allows you to view your stations overall performance, which can then be compared to another station to identify whether your station is running or not. The controller compiles this data automatically and places it in line graph format so that it is easier to identify any reductions in expected performance.

An alarm relay can be set to monitor the **Station API %**, see **Relays > Type > Alarms > Function > Station API**.

The **Station API** screen shows the total amount of energy used divided by the volume (m³) pumped per interval time set and the head in meters (m) to give you an average performance of the station.

Bottom axis of the graph shows the date and time, where the vertical axis shows the energy divided by volume and level (kWh/m³/m). This graph will plot up to 300 records of logging before pushing the oldest day 'out'.

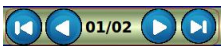
Use  arrows above the graph to scroll through the logged information pages.

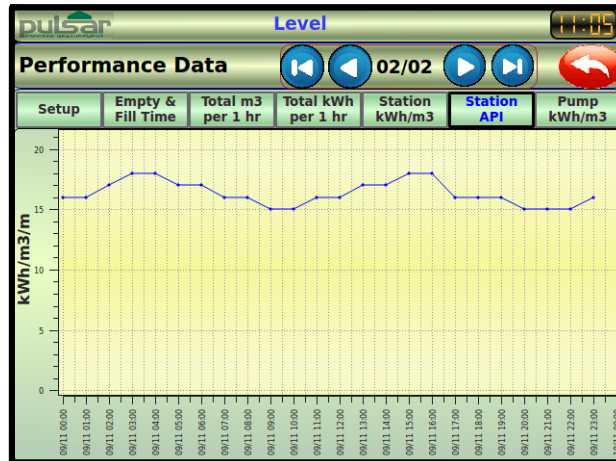

Pump kWh/m³

This screen shows the average amount of energy used by the individual pump(s) per cubic meter, per log interval time. The controller does this automatically and places the information in line graph format to make it easier to identify the performance of the pump(s). The colored box or boxes at the bottom of the screen represent each individual pump, and its information will be displayed on the line graph in that particular colour. This information can then be used to help identify a reduction in the efficiency of the individual pumps performance.

This shows the total amount of energy used divided by the volume (m³) per day of the individual pump(s) emptying the vessel to give you an average performance of each pump.

Bottom axis of the graph shows the date and indicates the colour of each pump, and the vertical axis shows the energy/volume (kWh/m³). This graph will plot up to 300 days of logging information before pushing the oldest day 'out'.

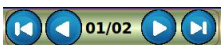
Use  arrows above the graph to scroll through the logged information pages.

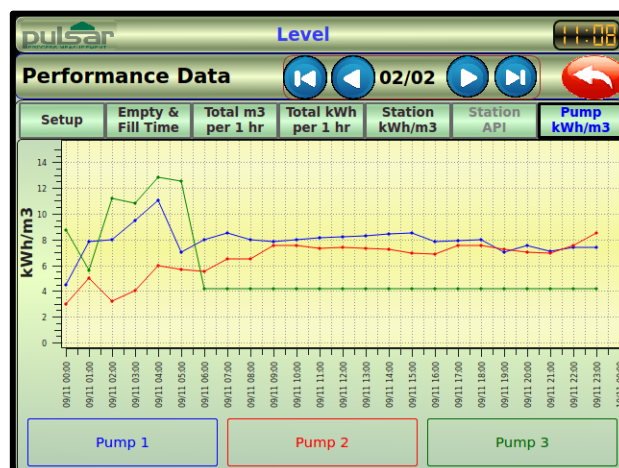

7.3 Pump Predictive Maintenance

This function is designed to help determine the condition of in-service pumps in order to predict when maintenance should be performed. This approach promises cost savings over routine or time-based preventative maintenance because tasks are performed only when warranted. The main purpose of this function is to allow convenient scheduling of corrective maintenance, and to prevent unexpected equipment failures. The idea being is 'to have the right information at the right time'. By knowing which equipment needs maintenance, the work can be better planned to cause shorter or fewer planned stops.

Performance Indicator

The **Performance Indicator** screen displays the calibrated (red line) and the up-to-date profile of the on/off setpoints of the selected pump (blue line). And will display the current (in Amperes) against the head (in measurement units).

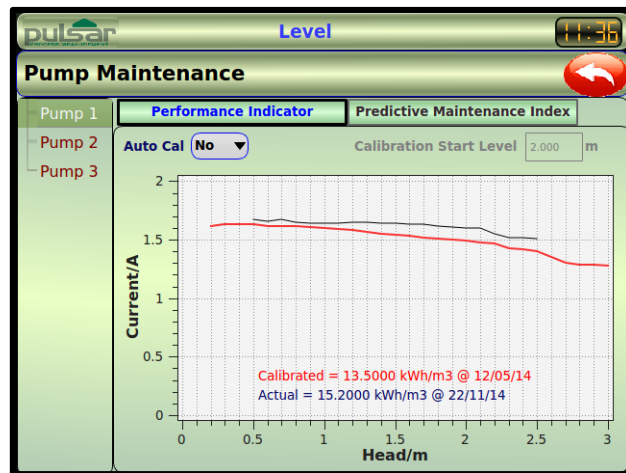

The information presented in Performance Indicator screen once setup, will allow you to distinguish the difference between the calibrated reading (red line) and the actual reading of the pump (blue line). This information is calculated by the controller, and the information displayed at the bottom of the graph showing the energy / volume pumped (kWh/m³) and the date the reading was taken of the performance of the pump selected.

Auto Calibration

This calibration process is required for Pump Efficiency, PMI and RetroFlo features. It can also be used to calibrate FlowPulse sensors to a drop test.

Selecting 'Yes' will allow the controller to automatically obtain the calibrated readings. When returning to run mode, you will notice on the main display a message appears 'Measuring Inflow' and in the event log 'Pump (no.) starting profile calibration'. Once the level set in **Calibration Start Level** has been reached a message will appear on the main display 'Calibrating pump (no).'

Once the pump has reached it's 'OFF' set point, a message will appear on the event log 'Pump (no.) Finish profile Calibration' as the controller has stored the calibrated data, which on the graph appears as the red line. This process will repeat for all pumps programmed on the application until all pumps are calibrated. The controller will continuously update the actual data taken from the pump on regular basis, which can then be viewed by returning to this screen to determine if there is any difference in performance from the first calibrated data stored.

Calibration Start Level

This is the level set in measurement units that the calibration of the pump will begin. To achieve the best results, ensure that the actual level of the vessel (taken from the level on main display screen) is above the 'ON' setpoints of any pumps and enter this level in here for when the calibration is to start.

The pumps can be re-calibrated at any time by repeating the auto calibration steps.

Predictive Maintenance Index (PMI)

The information contained in the PMI screen will provide details of the daily performance of the selected pump and allow viewing of its continued performance over a period of time (up to 300 records). This information will help to identify at an early stage, to reduce inconvenience on site, when a pump requires maintenance.

The information will be displayed here at the start of each day (midnight), and the **'Performance indicator'** will display the pumps performance of that day against the **'Performance Threshold'** that has been set in the **'PMI Threshold'** parameter box.

The **Predictive Maintenance Index** screen displays the **'Performance Threshold'** (red line) and the **'Performance Indicator'** (blue line). And will display the PMI (in a %) against the date for each individual pump selected from the list on the left-hand side of the screen.

This graph will plot up to 300 records of logging information before pushing the oldest day 'out'.

Use  arrows above the graph to scroll through the logged information pages.

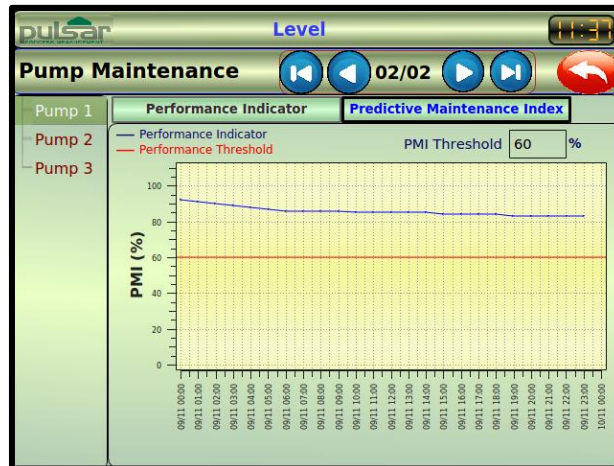

Performance Indicator

The blue line shows the current daily performance of the pump selected as a percentage of the calibrated performance. The data is then logged every day and in turn the graph will create a new plot to reflect the pumps performance for that day. The closer that this line gets to the **Performance Threshold** will indicate that there is wear on the pump and maintenance can be planned to rectify the issue to return the pumps performance to a higher level.

An alarm relay can be set to monitor and alert you if the **PMI %** falls to a specific level see **Relays > Type > Alarms > Function > Pump PMI**.

Performance Threshold

The red line displays the minimum level of performance as set in PMI Threshold (in %) that is allowed for each pump before maintenance or servicing is to be carried out.

PMI Threshold

This is set upon installation and decides the minimum percentage (%) of performance allowed for each pump.

7.4 Pumps Info

The data stored/recorded is dependent upon what Modules (devices) are being used and how the controller is configured for certain functions.

e.g., to record data related to power usage a power monitor(s) will be required and to record data related to pumped volume the controller will need to be configured for pumped volume.

This screen provides information on the individual pump relay data that is currently recorded and stored by your Ultimate controller and their current values.

By using the tree menu on the right of the screen select which Pump data you wish to view. Using the side bar on the left allows you to scroll up and down, through the list of recorded information.

The values that are shown on this screen can be reset with any value, or you can clear all the values that are shown by pressing the 'Clear' button.

Parameter	Value
Starts last week	0
Total kWh used	0.000
kWh/m3	0.000
Total pumped volume (m3)	0.000
Pumped Volume this week (m3)	0.000
Pumped volume last week (m3)	0.000
Num runons	0
Num exercises	0
Pump efficiency	0
Failed duration (min)	0.0
Num. demoted	0

7.5 Alarms Info

This screen provides information on the individual alarm relay data that is currently recorded and stored by your Ultimate controller and their current values.

By using the tree menu on the right of the screen select which Alarm data you wish to view. The values that are shown on this screen can be reset with any value, or you can clear all the values that are shown by pressing the 'Clear' button.

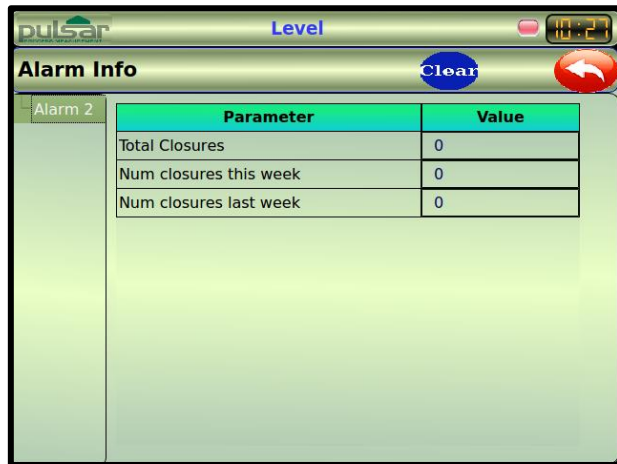

7.6 Controls Info

This screen provides information on the individual control relay data that is currently recorded and stored by your Ultimate controller and their current values.

By using the tree menu on the right of the screen select which Control data you wish to view. The values that are shown on this screen can be reset with any value, or you can clear all the values that are shown by pressing the 'Clear' button.

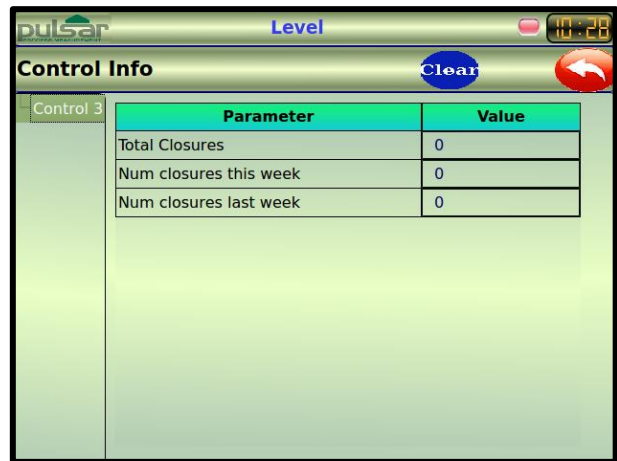

7.7 Misc. Info

This screen provides information on the individual miscellaneous relay data that is currently recorded and stored by your Ultimate controller and their current values.

By using the tree menu on the right of the screen select which Misc. data you wish to view. The values that are shown on this screen can be reset with any value, or you can clear all the values that are shown by pressing the 'Clear' button.

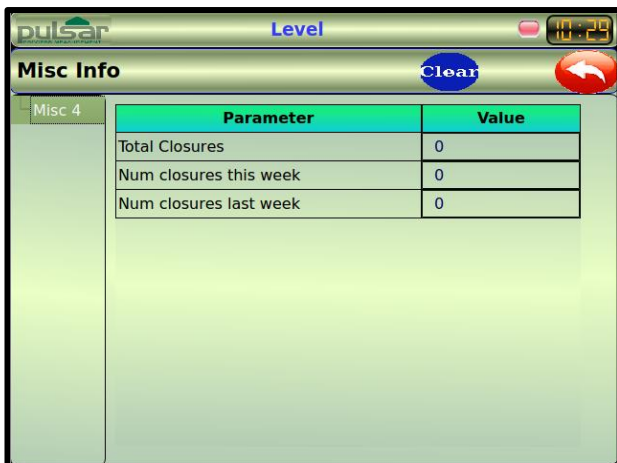

CHAPTER 8 ULTIMATE WEBSERVER

This section gives you instructions on how to use the Ultimate Webserver, so that the controller information can be viewed/changed, or information downloaded over an internet connection via the external 3G router.

Important Notice

Ensure that you have the IP address of the SIM card you have inserted into the external 3G router.

Open your internet explorer on your laptop/computer (Google Chrome, Mozilla Firefox, Microsoft Edge etc.). You will need to know the IP address of the Sim card in the 3G router that you are wishing to connect to. This information should come with the SD card you have inserted into the router.

Once you have the IP address of the sim card, this can then be typed into the web address bar of your internet explorer. You will then see the following screen appear:

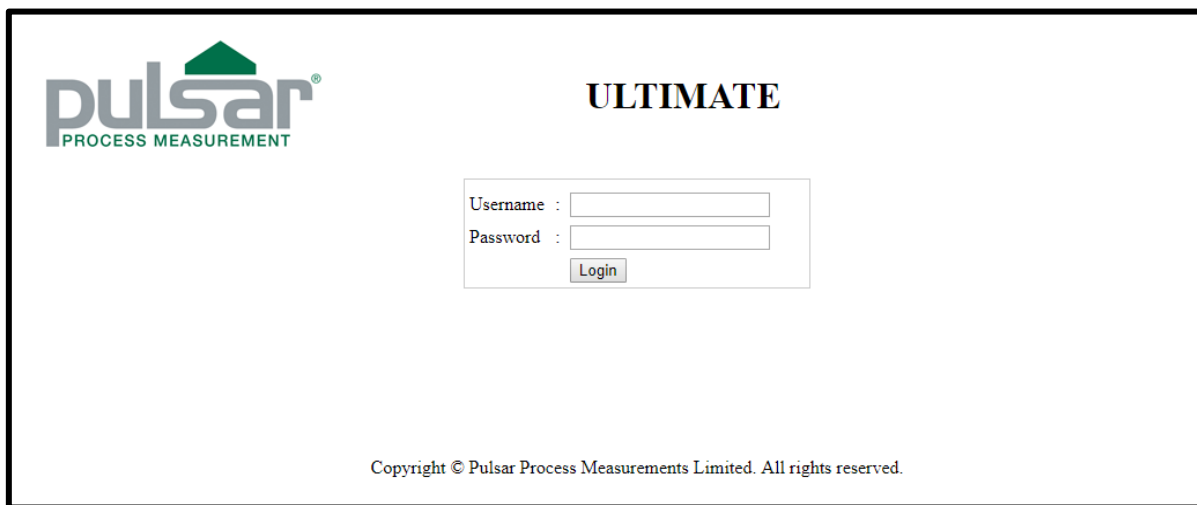

To access the Ultimate via the webserver you will need to enter the following information into the screen above:

Username: **Admin**

Password: **1997**

Then select the 'Login' button to be taken to the Ultimate webpage.

A representation of the Ultimate's main display screen will now appear on your computer, giving real-time information from the controller. There is great deal that the user can do through the Ultimate webserver, simply by selecting such as:

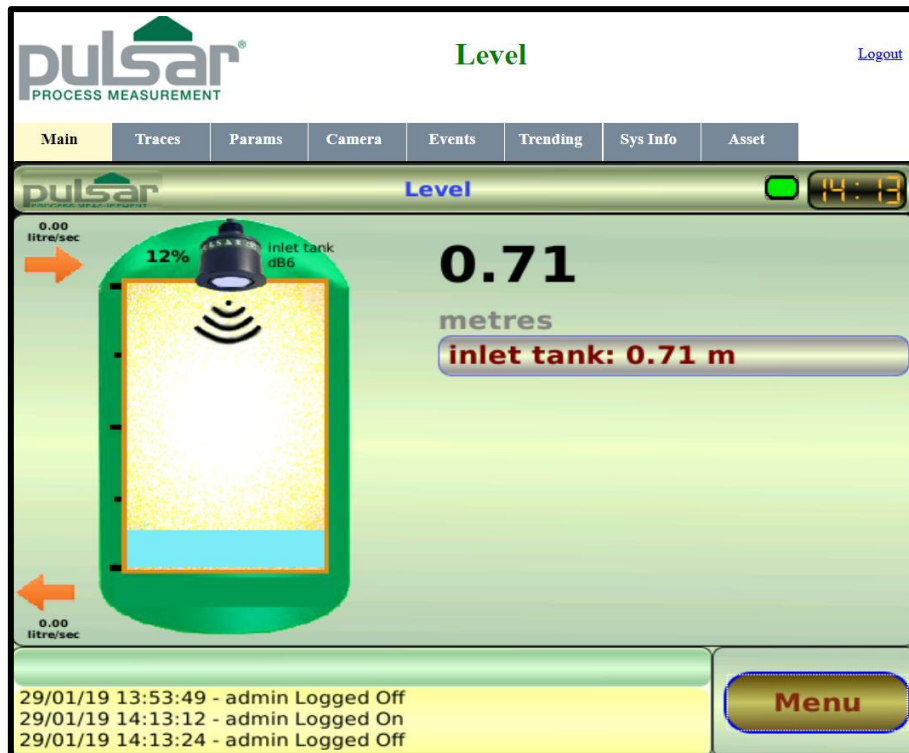

- View live measurements obtained from the controller, including any auxiliary display information set up.
- View the main display currently shown on the Ultimate, to see if pump and relays have been activated/deactivated.
- View transducer traces.
- View trending of measurement points setup.
- Download trending, performance, and application data logs.
- Ability to view and change the parameters programmed in the Ultimate.
- View station performance information and individual pump performance (dependent on program set).
- View peripheral device information such as MicroFlow, FlowPulse, Power Monitor etc. And change settings if required.
- View and download camera pictures and camera logs.
- View system information regarding the Ultimate.

When the username and passcode has been entered correctly you will see a representation of the Ultimate's main display. The display may vary if an OCM program or multiple auxiliary displays have been set, whatever is programmed onto the Ultimate itself will be mirrored on this page. The example shown below is for a basic level application.



Including the Main page, there are 7 selectable tabs on the webpage that will open and allow you to view and program different sections of the Ultimate Controller. As you explore the Ultimate webserver you will notice that there are different buttons/tabs that are selectable. The below key describes what these options do:

8.1 Webserver key

SELECTABLE OPTION	DESCRIPTION
Logout	Selecting this enables you to exit the webserver and log you out as you exit.
Reload	Pressing this will reload the current webpage and cancel and unsaved changes made.
	Returns you to the previous webpage, without saving any changes.
App Log	Press this button to update the webpage and save any changes made to the Ultimate Controller you are connected to.
Performance Log	Selecting this will allow you to download all the current Application logs from the Ultimate into a .CSV format.
Trending Log	Selecting this will allow you to download all the current Station, API & Pump performance logs from the Ultimate into a .CSV format
	Selecting this will allow you to download the current trending information from the Ultimate into a .CSV format.
Camera pictures	Pressing this icon will allow you to refresh the webpage.

8.2 Traces Webpage

Selecting the 'Traces' tab page will display the echo traces from any active dB transducers or Radar sensor. Select between the transducers by using the dropdown list at the top of the screen. The checkboxes select which traces are shown. The individual trace line information (DATEM, Loss Limit, Normalised and Raw Echo) is displayed at the right-hand side of the web page.

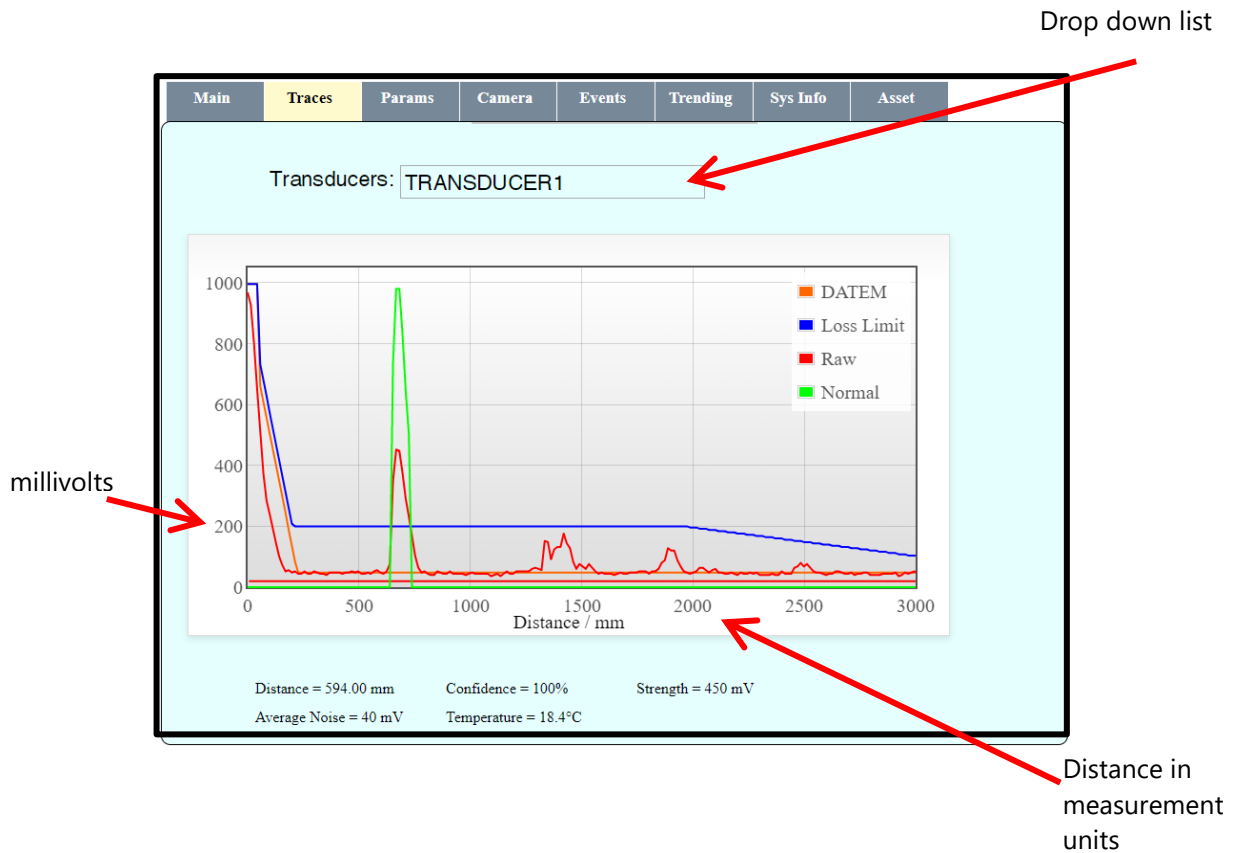

Any transducer selected from the drop-down box will display the current up to date echo trace information. Also, at the bottom of the trace page are the details of the current distance, average noise, confidence, strength, and temperature reading currently seen by the transducer.

8.3 Parameters Webpage

This page allows the user to view and make changes to specific parameters that are currently programmed into the controller. There is the option to also program parameters remotely that have not been set in the unit itself. When you first enter the parameters page you start at the application section, from here you can see what has been set in the controller. Details of the individual parameter pages are shown in this section.

mA Inputs

This menu defines the type and range of sensor being used at the mA inputs. As in the Ultimate itself, you are able to utilise a 5-point linearization between the mA input value and the process variable it represents.

The tree list selects which input is currently being configured. An identical screen is used to configure the range of input 2. Configuration of a sensor type of a mA input, can be done by the Ultimate directly. For more information on how to do this, please refer to **Chapter 4 – section 4.2 Application Setup**. If a change is made on any of the options below, the Update and Cancel buttons will appear to either confirm and send the change to the Ultimate, or cancel the change and leave the program as it is.

Name	Location	Sensor Type	ExTemp Type	ExTemp Scale	ExTemp Offset
mA1 In	IFB1(126)	Flow			
mA2 In	IFB1(126)	Level			

Measurement Points

Measurement points will be listed on this page as shown in the example below, identifying how many measurement points are set, the given/programmed names of each point, the mode and operation that each point is set to. New points can be added, or existing ones deleted via the Ultimate itself.

Number	Name	Mode	Operation
1	well level	Level	Single
2	channel	Flow	Single
3	well rate	Rate	Single

Relays Webpage

The different relays that are currently programmed into the Ultimate and their setpoints can be viewed on this page. You can switch between Pumps, Alarms, Controls, Misc and Logic relays that may be set in the Ultimate, depending on your application. You can adjust the setpoints of each relay that is currently programmed into the Ultimate via the webserver. However, to add or remove a relay will need to be carried out on the Ultimate itself. If there are no relays programmed for a specific function, the webserver will display a message stating that no relays have been set. For more information on the configuration of relays in an Ultimate, please refer to **Chapter 4 – section 4.3 Relays**. If a change is made on any of the parameters below, the Update and Cancel buttons will appear to either confirm and send the change to the Ultimate, or cancel the change and leave the program as it is. The following screenshots show the different relay types and an example of the information programmed into the Controller:

Pumps

Name	Details	Allocation	Setpoint1	Setpoint2	Setpoint3	Setpoint4	Closure	Failsafe	Flow	Power	MaxRate	standby	eventSMS
Pump 1	Group:1(FDA)	inlet tank	2.00 m	1.00 m			0	0			0 m/min	<input type="checkbox"/>	<input type="checkbox"/>

Alarms

Name	Function	ID	Allocation	Setpoint1	Setpoint2	Setpoint3	Setpoint4	Closure	Failsafe	eventSMS	eventSound
Alarm 2	Meas.Point	Hi	inlet tank	4.60 m	4.00 m			0	0	<input type="checkbox"/>	<input type="checkbox"/>

Controls

Pumps Alarms Controls Misc Logical									
Name	Function	ID	Allocation	Setpoint1	Setpoint2	Setpoint3	Closure	Failsafe	eventSMS
Control 3	Meas.Point		inlet tank	2.50 m	1.80 m		0	0	<input type="checkbox"/>

Misc

Pumps Alarms Controls Misc Logical						
Name	Function	Setpoint1	Setpoint2	Closure	Failsafe	eventSMS
Misc 4	Totaliser	100 m3	1 sec	0	0	<input type="checkbox"/>

Logical

Pumps Alarms Controls Misc **Logical**

No Logic Relays setup

Pump Advanced Webpage

This page allows you to setup the various pump advanced functions that are available in the Ultimate. Each of which are as shown in the below picture. The pump advanced features can be enabled/disabled and values of each changed via the webserver. For more information on the Pump Advanced features of the Ultimate, please refer to **Chapter 4 - section 4.4 Pump Advanced**. If a change is made on any of the parameters below, the Update and Cancel buttons will appear to either confirm and send the change to the Ultimate, or cancel the change and leave the program as it is.

Application	Relays	Pump Advanced	Digital Inputs	Sensors	Volume App.	Display	mA Out
Ultrasonic sensor		Remote Alarms					

RunOn		Exercise		Delays		RunTime	
Parameter	Value	Parameter	Value	Parameter	Value	Parameter	Value
Enabled	<input type="radio"/> yes <input checked="" type="radio"/> no	Enabled	<input type="radio"/> yes <input checked="" type="radio"/> no	Enabled	<input checked="" type="radio"/> yes <input type="radio"/> no	Enabled	<input type="radio"/> yes <input checked="" type="radio"/> no
Prime Level	0.00 mm	Idle Time	720.00 mins	Power Delay	10 secs	Max.RunTime	99999.00 mins
Run Interval	0.00 hours	Exercise Time	30.00 secs	Start-Start Delay	10 secs	Max.Starts	99
Run Duration	0.00 secs	Min. Head	0.00 mm	Stop-Stop Delay	0 secs	In Interval	9999.00 mins
Min. Head	0.00 mm			Start-Stop Delay	0 secs	Max. RunPumps	99
				Stop-Start Delay	0 secs	MaxStart Override	99999.00 mm

Autoreset		PumpedVolume		Efficiency		Storm Detect	
Parameter	Value	Parameter	Value	Parameter	Value	Parameter	Value
Enabled	<input type="radio"/> yes <input checked="" type="radio"/> no	Source	None	Enabled	<input type="radio"/> yes <input checked="" type="radio"/> no	Enabled	<input type="radio"/> yes <input checked="" type="radio"/> no
Consec. Trip	3.00	Settle Time	60.00 secs	Persist count	6.00	Disable Time	0.00 mins
24HourTrip	10.00	Pump rate limit	10.00 %	Demote Pump	<input type="radio"/> yes <input checked="" type="radio"/> no		
Reset Interval	10.00 secs	Allocation		Inflow Delay	45.00 secs		
Reset Pulse	3.00 secs	Tot. Units	m3	Sample Rate	1.00 secs		
		Multiplier	*1				
		Decimals	2				

Override		Odour Reduction		Block & Burst		Peak Tariff	
Parameter	Value	Parameter	Value	Parameter	Value	Parameter	Value
Enabled	<input type="radio"/> yes <input checked="" type="radio"/> no	Wall Cling Enable	<input type="radio"/> yes <input checked="" type="radio"/> no	Enabled	<input type="radio"/> yes <input checked="" type="radio"/> no	Enabled	<input type="radio"/> yes <input checked="" type="radio"/> no
Override Delay	5.00 secs	Max Band	0.00 mm	RMA Delay	5 secs	Ovf. Level	99999. mm
Min. Override	0.00 mm	Sep. Enable	<input type="radio"/> yes <input checked="" type="radio"/> no	Flow Method	<input checked="" type="radio"/> Derived Flow <input type="radio"/> Flow Pulse	Lead Time	3.00 mins
		Idle Interval	60.00 mins	Settle Period	10 secs	Lag Time	6.00 mins
		Min Head	0.00 mm			Min. Run	60.00 secs

Time to Spill		OverSpill Counts		Backup Control		VSD Pumps	
Parameter	Value	Parameter	Value	Parameter	Value	Parameter	Value
Enable	<input type="radio"/> yes <input checked="" type="radio"/> no	Enable	<input type="radio"/> yes <input checked="" type="radio"/> no	Enabled	No	Name	VSD 1
Persist	10	Spill Level	99999.00 mm	Hi Level1	0 mm	Start Output	80 %
Hi Alarm	99999.00 mm	First Period	12.00 hrs	Hi Level2	0 mm	Ramp Up	10 secs
Min Head	0.00 mm	Next Period	24.00 hrs	Pump Time	0 secs	Min. Output	20 %
Ovf. Level	99999.00 mm	Display OVF	<input type="radio"/> yes <input checked="" type="radio"/> no	Persist Time	30 secs	Max. output	100 %
		Spill percent	80.00 %				

Digital Inputs Webpage

The Digital Inputs page is used to configure any new digital inputs and to view or edit existing configured digital inputs. The configuration of a new digital input or to delete the configuration of an existing input must be carried out in the Ultimate directly. Input type, function and allocation of an existing digital input can be viewed and edited using the webserver. For more information on the digital input configuration in the Ultimate, please refer to **Chapter 4 – section 4.5 Digital Inputs**. An example of the digital inputs page is shown below:

Common Settings
Input filter : 1
Switch Mode: Standard

Location (addr)	Name	Assignment	Input type	Function	Allocation
IFB1(126)	DIN 01	Pump	Active Low ▼	Failed ▼	Pump 1 ▼
IFB1(126)	DIN 02	not assigned			
IFB1(126)	DIN 03	not assigned			
IFB1(126)	DIN 04	not assigned			
IFB1(126)	DIN 05	not assigned			
IFB1(126)	DIN 06	not assigned			
IFB1(126)	DIN 07	not assigned			
IFB1(126)	DIN 08	not assigned			

Sensors Webpage

The sensors page allows for the configuration parameters for ancillary devices connected via the PBUS expansion port, and also lists the Modbus address of the sensor connected. Sensor configuration settings will only be accessible if the sensor has been registered as a Hardware Module from within the Ultimate itself. If a change is made on any of the options below, the Update and Cancel buttons will appear to either confirm and send the change to the Ultimate, or cancel the change and leave the program as it is. If a sensor has not been set on the Ultimate, the webpage will state that the specific sensor has not been set. For more information on how to setup sensors please refer to **Chapter 4 – section 4.6 Sensors**.

FlowPulse

Flowpulse Power Monitor MicroFlow Speedy

Name(addr)	Sensitivity	PipeID (m)	Damping	Calibration (%)	StepResp.	Resp.Thresh.	Resp.Limit	Density	TrackMeth
FlowPulse 1 (19)	1600	0.015	24	100	Yes	60	120	Medium	0



Power Monitor

Flowpulse Power Monitor MicroFlow Speedy

Name(addr)	Turns ratio	RS485 Term	IRT Enable	IRT Interval (hrs)	Filtering
PWR 1 (2)	100	No	Yes	168	No



MicroFlow

Flowpulse Power Monitor MicroFlow Speedy

Name(addr)	Gain	Damping	Damping Persist	Step Resp.	Step Persist	Response	Min.Velocity (mm/sec)	Max.Velocity (mm/sec)	termination	Calibration %
MicroFlow 1 (3)	10	24	12	On	12	Slow	0.00	6000.00	No	100



Speedy



Volume Webpage

This page displays the setup a volume profile which is currently programmed on the Ultimate. Each volume profile that is programmed in the Ultimate will appear as a tab on the page as Vol. 1, Vol. 2 etc. You are unable to change the name, allocation, or vessel shape on the page. However, the rest of the parameters can be changed. If a change is made on any of the options below, the Update and Cancel buttons will appear to either confirm and send the change to the Ultimate, or cancel the change and leave the program as it is. If a volume profile has not been set on the Ultimate, the webpage will state that no volume has been setup. For more information on Volume please refer to **Chapter 4 – section 4.7 Volume**.

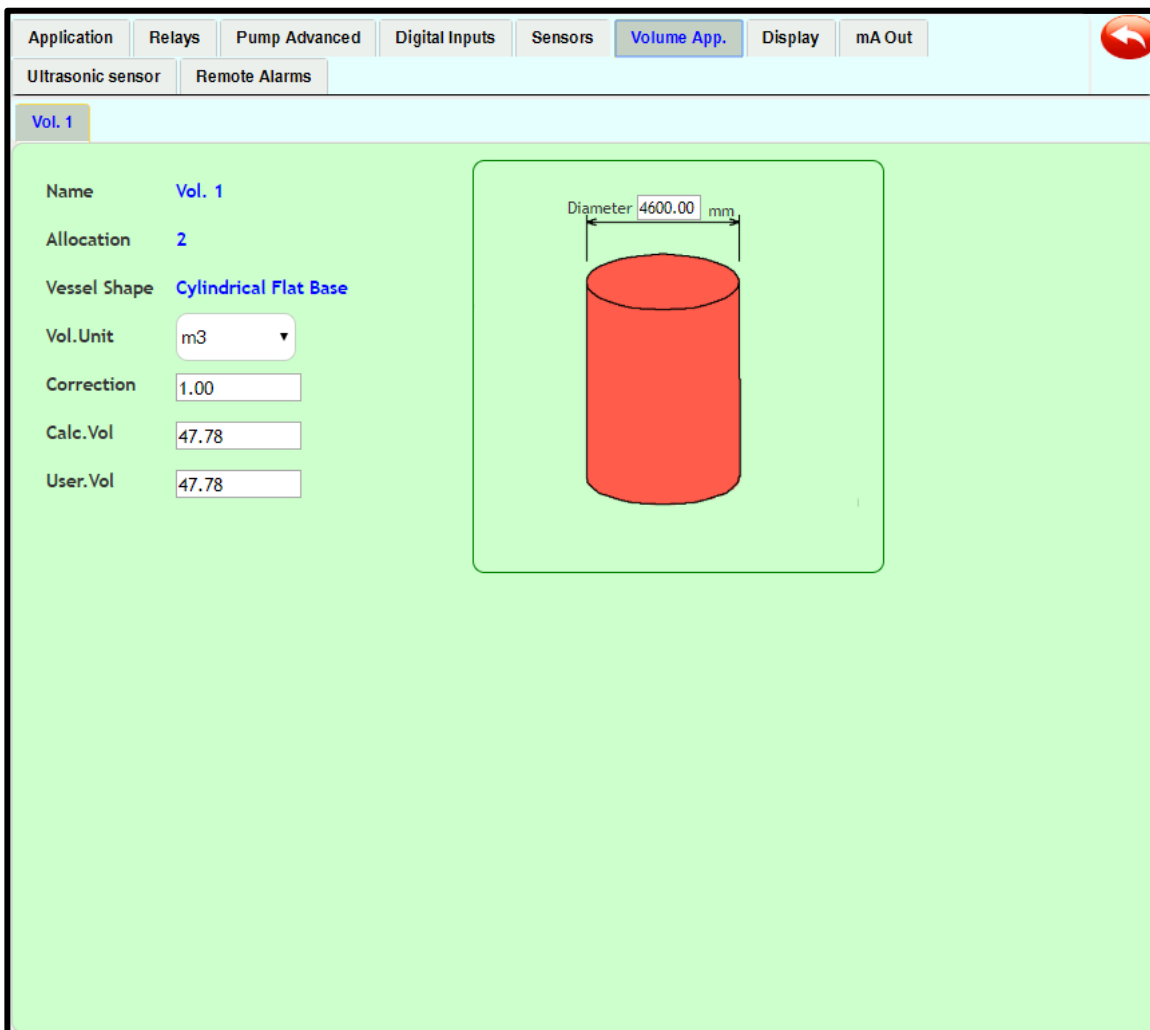

Display Webpage

This page allows you to view or edit the display menu's which allow you to choose what is displayed on the screen of the Ultimate controller when in Run Mode, whether it is the main or auxiliary display. Or what happens and is displayed in the event of a failsafe condition. If a change is made on any of the options below, the Update and Cancel buttons will appear to either confirm and send the change to the Ultimate, or cancel the change and leave the program as it is. Below is a picture of the main display web page. For more information on how to use the display features, please refer to **Chapter 4 – section 4.9 Display**.

The screenshot shows a web interface for configuring display settings. At the top, there is a navigation bar with tabs: Application, Relays, Pump Advanced, Digital Inputs, Sensors, Volume App., Display (selected), and mA Out. Below this is a sub-menu with 'Ultrasonic sensor' and 'Remote Alarms'. The main content area has three sub-tabs: 'main' (selected), 'Aux', and 'Failsafe'. The 'main' tab contains several configuration sections:

- Display Settings:** 'Display' dropdown set to 'measured', 'Decimals' dropdown set to '2', 'Source' dropdown set to 'Level', 'Allocation' dropdown set to 'well level', 'Offset' text input set to '0.00', and 'Conversion' text input set to '1'.
- Flow Units:** 'Show' dropdown set to 'yes', 'unit' dropdown set to 'litres', a separator '/', 'sec' dropdown, and 'Decimals' dropdown set to '2'.
- OCM Meas.Points:** 'Volume Units' dropdown set to 'm3', a separator '/', and 'sec' dropdown.
- Volume Meas.Points:** 'Volume Units' dropdown set to 'tonnes'.

Auxiliary Display Webpage

main **Aux** Failsafe

Aux1

Display	<input type="text" value="measured"/>	Decimals	<input type="text" value="2"/>
Offset	<input type="text" value="0.00"/>	Conversion	<input type="text" value="1"/>
Source	Points	Allocation	well level

Aux2

Display	<input type="text" value="measured"/>	Decimals	<input type="text" value="2"/>
Offset	<input type="text" value="0.00"/>	Conversion	<input type="text" value="1"/>
Source	Points	Allocation	well level

Failsafe Webpage

main Aux **Failsafe**

Fail Time sec

Fail Mode

mA Out Webpage

This page allows you to view or edit the mA output configuration the mA outputs for their intended use. You are unable to change the name, source, or allocation of the mA output. However, you are able to other parameters where a white box is shown. If a change is made on any of the options below, the Update and Cancel buttons will appear to either confirm and send the change to the Ultimate, or cancel the change and leave the program as it is. For more information on how to use the display features, please refer to **Chapter 4 – section 4.10 mA Outputs**.

Location (addr)	Name	Range	Source	Allocation	Low Level	High Level	Low Limit (mA)	High Limit (mA)	Fail Mode	Override	Ovr. out (mA)
IFB1 (126)	mA1 Out	4 ~ 20 mA	VSD Control	VSD 1	0.00 %	100.00 %	4.00	20.00	Hold	None	20.00
IFB1 (126)	mA2 Out	4 ~ 20 mA	VSD Control	VSD 2	0.00 %	100.00 %	4.00	20.00	Hold	None	20.00

Ultrasonic Sensor Webpage

This page allows you to view the transducer(s) and edit currently programmed on the Ultimate. You are unable to change the selection of the dB transducer type. However, you view and edit the settings of parameters that have white boxes next to them. This includes compensation, stability, echo process, empty distance, span, and blanking distances. If any additional Interface Board's (IFB) have been registered on the PBUS, the page will include any extra dB transducer inputs available.

Application
Relays
Pump Advanced
Digital Inputs
Sensors
Volume App.
Display
mA Out

Ultrasonic sensor
Remote Alarms

TDR1
TDR2

TRANSDUCER1

Compensation

Parameter	Value
Meas. Offset	0.00
Temp. sources	Automatic
Temp Offset	0.00 °c
Fixed Temp	20.00 °c
Temp Average	3
Sound Velocity	342.72 m/s

Stability

Parameter	Value
Rate update	Continuous
Rate Sampling	1.00
Rate Array	4
Process Filter	Slow
Fill Damping	10000.00 mm/min
Empty Damping	10000.00 mm/min

Echo Process

Parameter	Value
Sensitivity	5.00 dB
Side Tolerance	50.00 mm
Gate Mode	Calculated
Fixed Distance	200.00 mm

Service parameters will appear in this section when a service passcode is entered.

Please do not attempt to change service parameters without the assistance of a service technician.

Remote Alarms Webpage

This page allows you to view and edit the remote alarm information. An internal GSM modem is required to enable this feature to operate correctly. For more information on the use of remote alarms, please refer to **Chapter 4 – section 4.14 Remote Alarms.**

Application	Relays	Pump Advanced	Digital Inputs	Sensors	Volume App.	Display	mA Out						
Ultrasonic sensor	Remote Alarms												
Event SMS													
Enable	<input type="checkbox"/>	Delay	<input type="text" value="30"/>	sec									
Interval SMS													
Enable	<input type="checkbox"/>	Interval	<input type="text" value="60"/>	mins	Memory Index	<input type="text" value="92"/>							
<i>Sump level percent</i>													
Mon	<input checked="" type="checkbox"/>	Tue	<input checked="" type="checkbox"/>	Wed	<input checked="" type="checkbox"/>	Thu	<input checked="" type="checkbox"/>	Fri	<input checked="" type="checkbox"/>	Sat	<input checked="" type="checkbox"/>	Sun	<input checked="" type="checkbox"/>
Start Time (hh:mm)	<input type="text" value="0"/>	:	<input type="text" value="0"/>	End Time (hh:mm)	<input type="text" value="23"/>	:	<input type="text" value="59"/>						
Telephone Numbers													
#1	<input type="text"/>	#2	<input type="text"/>										
#3	<input type="text"/>	#4	<input type="text"/>										
#5	<input type="text"/>	#6	<input type="text"/>										

8.4 Camera Webpage

This page allows the user to view the images captured on the Pulsar CCTV camera at near real time on an application process, or application site via the still images taken at regular intervals. Clicking on the picture will cause the image to refresh and display a new camera image capture. For more information on how to setup the Pulsar CCTV camera please see **Chapter 5 – section 5.6 CCTV Camera**.

Main	Traces	Params	Camera	Events	Trending	Sys Info	Asset
------	--------	--------	--------	--------	----------	----------	-------



Click on picture to refresh

Date/Time	Size
18-03-2019 14:18:25	13 kb

Copyright © Pulsar Process Measurements Limited. All rights reserved.

8.5 Events Webpage

This page allows the user to view the time and date of the last 300 events that have occurred on the Ultimate. Which includes the starting/stopping of pumps, alarms, activation and deactivation of pump advanced features, modules that have been added and if anyone has logged on/off on to the Ultimate controller directly. The event logs can be downloaded by selecting the [Event Log](#). For more information on the Ultimate event logs please refer to **Chapter 3 How to use your Ultimate Controller**.

Main	Traces	Params	Camera	Events	Trending	Sys Info	Asset
------	--------	--------	--------	--------	----------	----------	-------

Date	description
19/03/19 12:10:38	admin Logged Off
19/03/19 12:10:59	Pump 1 Started
19/03/19 12:11:09	Pump 2 Started

8.6 Trending Webpage

This page allows you to view the current information that the Ultimate automatically trends all measurements used in an application setup. A new trend will be started each time the Ultimate is power cycled. For more information on trending setup please refer to **Chapter 5- section 5.3 Log Setup**.

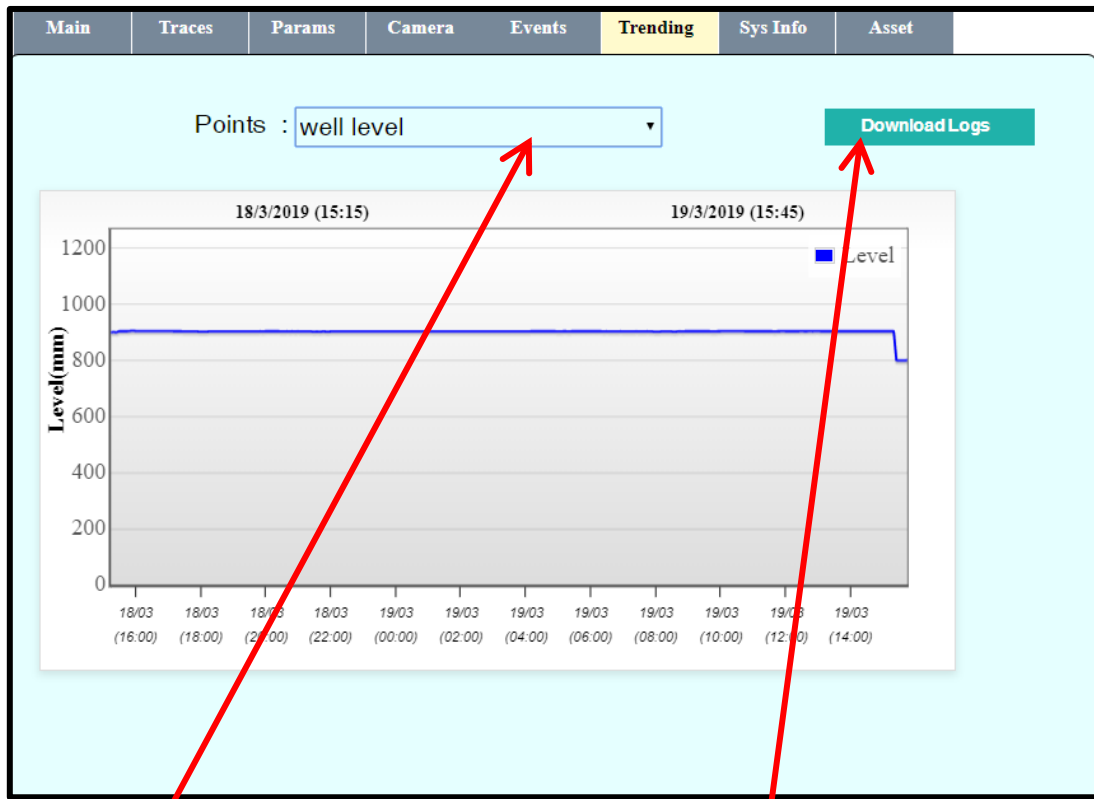

This allows you to select the trending point to be viewed from the drop-down list available.

Selecting this option will allow you to download the trending logs of all measurement points currently set in the Ultimate. The interval at when trends are

8.7 System Info Webpage

This page allows you to view the Ultimate's system information, which includes the firmware version, hardware version, serial number, any modules attached to the controller and much more. An example of the information found regarding the system information is shown in the screenshot below. These details are for information only and may be required by Pulsar, when making technical enquiries. For further information regarding the Ultimate's system information, please refer to **Chapter 6 – section 6.8 Software**.

The screenshot displays a web interface with a navigation bar at the top containing the following tabs: Main, Traces, Params, Camera, Events, Trending, Sys Info (highlighted), and Asset. The main content area is titled "System Info" and lists the following information:

Firmware : 2.1.13	<u>Interfaces :</u>
Hardware : 2.1.0	IFB 1 (126,v2.3)
Kernel version : 2.0	<u>FlowPulses :</u>
OS version : 3.4-rc3	FPLS 1 (2)
Configuration : 1.1 (def. 1.1)	<u>MicroFlow :</u>
Build time : 13.39.180219	MFLO 1 (3)
Task Manager : 4.0 (Running)	
Web Server : 4.0 (Running)	
RTU Server : 2.0.4 (cfg.1.000) (Stopped)	
Media Server : 3.0 (Running)	
Screenshot : 1.3 (Running)	
Serial number : 9876	
RTU Available : Not Selected	
Service due in : 9723 days	

8.7 Assets Webpage

This page allows you to view different information from the Ultimate which can assist in efficiently maintaining and servicing station assets by recording and logging all relevant station data and presenting this data in a format that enables informed maintenance decisions to be made, where considerable long term cost savings can be made.

Station assets Webpage

This page allows you to view the Station Info data that is currently stored/recorded by your Ultimate controller and their values. This information is read only and can only be reset by an administrator or hard default on the Ultimate itself. For more information on Station information, please refer to **Chapter 7 – section 7.1 Overall Station Data**.

Main	Traces	Params	Camera	Events	Trending	Sys Info	Asset
Station		Performance	Pumps Data	OCM	Common Totalisers		
Time to service	: 0 days		Total kWh used	: 0.00			
Fill cycles this week	: 13		Pump reversal count	: 0			
Avg. Fill time this week	: 0.00 minutes		Storm disable pump count	: 0			
Empty cycles this week	: 0		Num storm detected	: 0			
Avg. Empty time this week	: 0		Overflow duration	: 0.00 minutes			
Pump starts this week	: 13		Num Spill count	: 0			
Total Pump runtime this week	: 0.48 minutes		Pump fault count	: 0			
Total Pumped volume Pumped System	: 0.00 (m3*1)		Pump fault duration	: 0.00 minutes			
Pumped Resettable tots.	: 0.00 (m3*1)		Num alarms	: 6			
Pumped Daily tots.	: 0.00 (m3*1)		Num alarms this week	: 6			
Num Blocks detected	: 0		Invalid logons	: 0			
Num Bursts detected	: 0						

Performance logs Webpage

This page displays chart views of the historical performance data of the station and pumps monitored by the Ultimate. The amount of available data will depend up on the sensors connected to the system e.g. power monitors, FlowPulse or flow meters etc. For more information on Performance logs, please refer to **Chapter 7 – section 7.2 Logged Performance**.

Station		Performance		Pumps Data		OCM		Common Totalisers																												
General		Fill & Empty		m3 / 1 hr		kWh / 1 hr		kWh / m3																												
		API		PMI																																
<table border="1"> <thead> <tr> <th colspan="2">Station Performance</th> <th>Value</th> </tr> </thead> <tbody> <tr> <td>Total pumped volume</td> <td></td> <td>0.00 m3</td> </tr> <tr> <td>Total power consumption</td> <td></td> <td>0.00 kWh</td> </tr> <tr> <td>Measured PMI</td> <td></td> <td>0.00 kWh/m3</td> </tr> <tr> <td>Asset Performance Index (API)</td> <td></td> <td>10.00 kWh/m3/m</td> </tr> </tbody> </table>					Station Performance		Value	Total pumped volume		0.00 m3	Total power consumption		0.00 kWh	Measured PMI		0.00 kWh/m3	Asset Performance Index (API)		10.00 kWh/m3/m	<table border="1"> <thead> <tr> <th colspan="3">Pump Performance</th> </tr> <tr> <th>Pump Name</th> <th>PMI Threshold</th> <th>PMI</th> </tr> </thead> <tbody> <tr> <td>Pump 1</td> <td>60%</td> <td>0%</td> </tr> <tr> <td>Pump 2</td> <td>60%</td> <td>0%</td> </tr> </tbody> </table>					Pump Performance			Pump Name	PMI Threshold	PMI	Pump 1	60%	0%	Pump 2	60%	0%
Station Performance		Value																																		
Total pumped volume		0.00 m3																																		
Total power consumption		0.00 kWh																																		
Measured PMI		0.00 kWh/m3																																		
Asset Performance Index (API)		10.00 kWh/m3/m																																		
Pump Performance																																				
Pump Name	PMI Threshold	PMI																																		
Pump 1	60%	0%																																		
Pump 2	60%	0%																																		

Fill & Empty Webpage

This page allows you to view the empty and fill times of the vessel that is programmed into your controller. This will show you in line graph format the average time that it takes for your vessel to fill (indicated by the blue line) and be emptied by the pump(s) (indicated by the red line). For more information on Fill & empty logs, please refer to **Chapter 7 – section 7.2 Logged Performance**. **USE THE ARROWS TO VIEW DIFFERENT LOGGED DATA PAGES.**

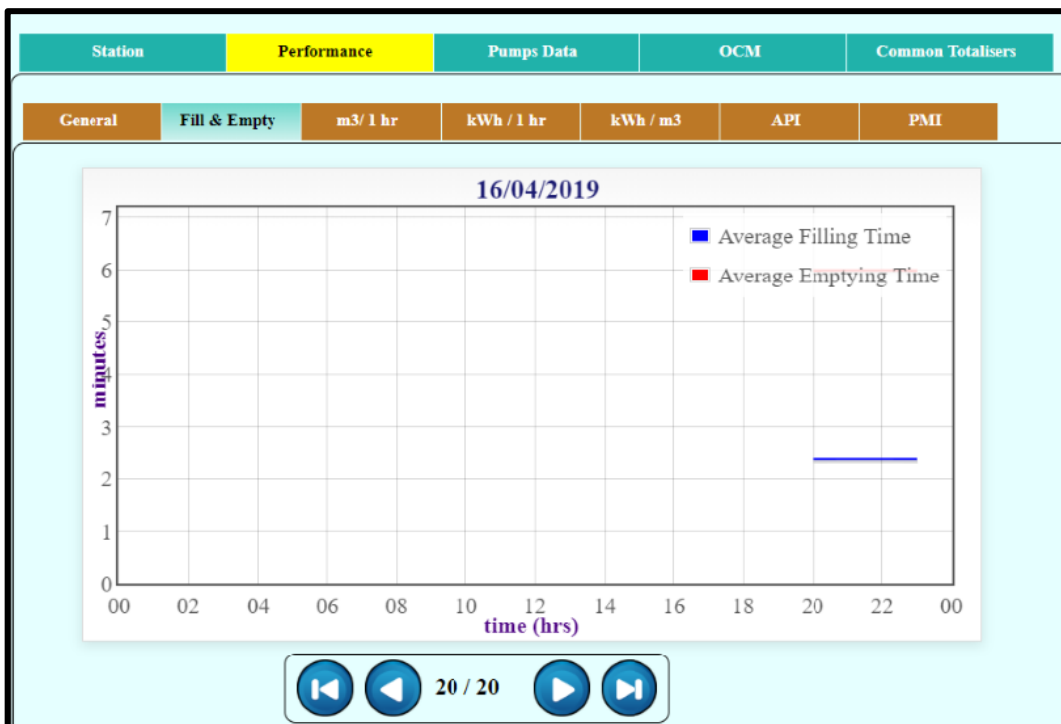

m³/1 hour Webpage

This page allows you to view the total volume of material that has been pumped from a vessel in cubic meters (m³). This is shown in line graph format and displays the amount of material in m³ pumped over a time period by the pump(s) in the vessel. For more information on m³/hour logs, please refer to **Chapter 7 – section 7.2 Logged Performance**. **USE THE ARROWS TO VIEW DIFFERENT LOGGED DATA PAGES.**

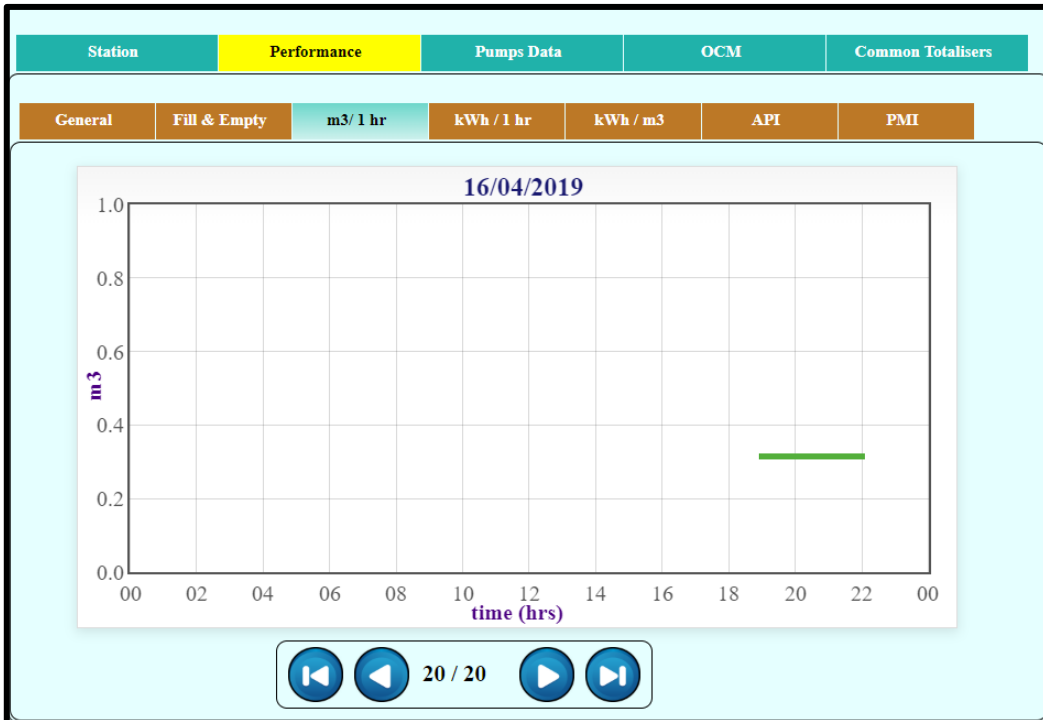

kWh/1 hour Webpage

This page displays the total amount of energy used in kWh in the log interval by the pump(s) to pump the material from the vessel. This information is shown in line graph format to make it easier to identify the amount of energy used. Information displayed on the page could help to identify any efficiency problems with the pump(s) and they may require maintenance. For more information on m³/hour logs, please refer to **Chapter 7 – section 7.2 Logged Performance**. **USE THE ARROWS TO VIEW DIFFERENT LOGGED DATA PAGES.**

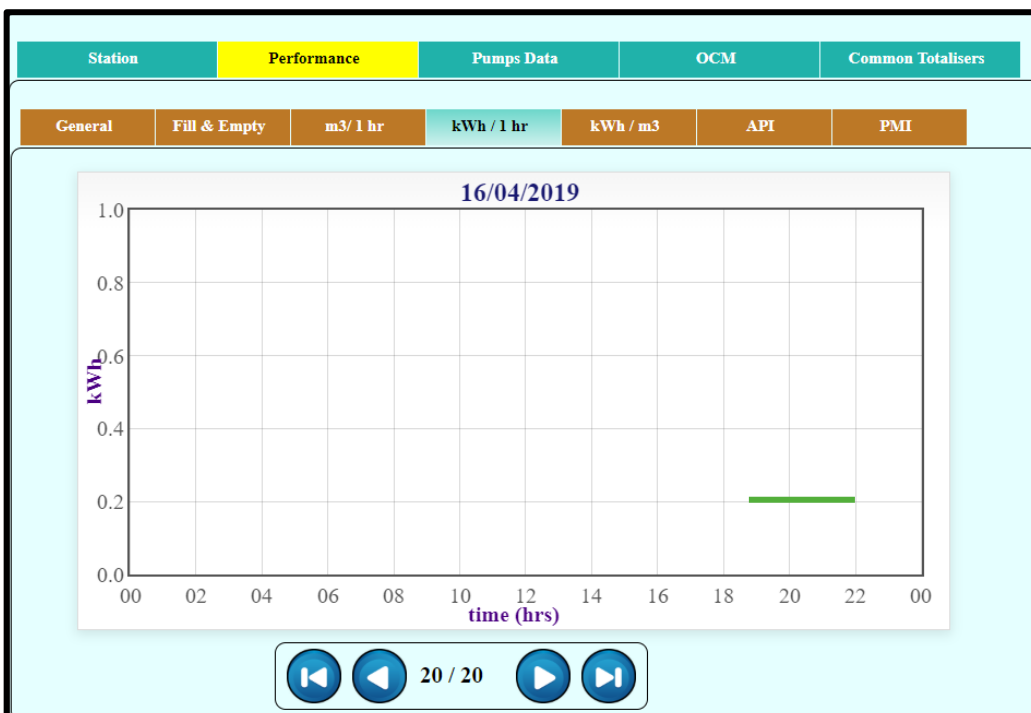

kWh/m³ Webpage

This page shows the total average amount of energy used by the pump(s) per cubic meter, per log interval time set. The controller does this automatically and places the information in line graph format to make it easier to identify the performance of the pumping application. This information can be used to identify a reduction in the efficiency of the pumping application. For more information on kWh/m³ logs, please refer to **Chapter 7 – section 7.2 Logged Performance**. **USE THE ARROWS TO VIEW DIFFERENT LOGGED DATA PAGES.**



Station API Webpage

This page shows the information when a 'Rising Main Pressure' is selected, and allows you to view your stations overall performance, which can then be compared to another station to identify whether your station is running or not. The controller compiles this data automatically and places it in line graph format. For more information on API logs, please refer to **Chapter 7 – section 7.2 Logged Performance**.

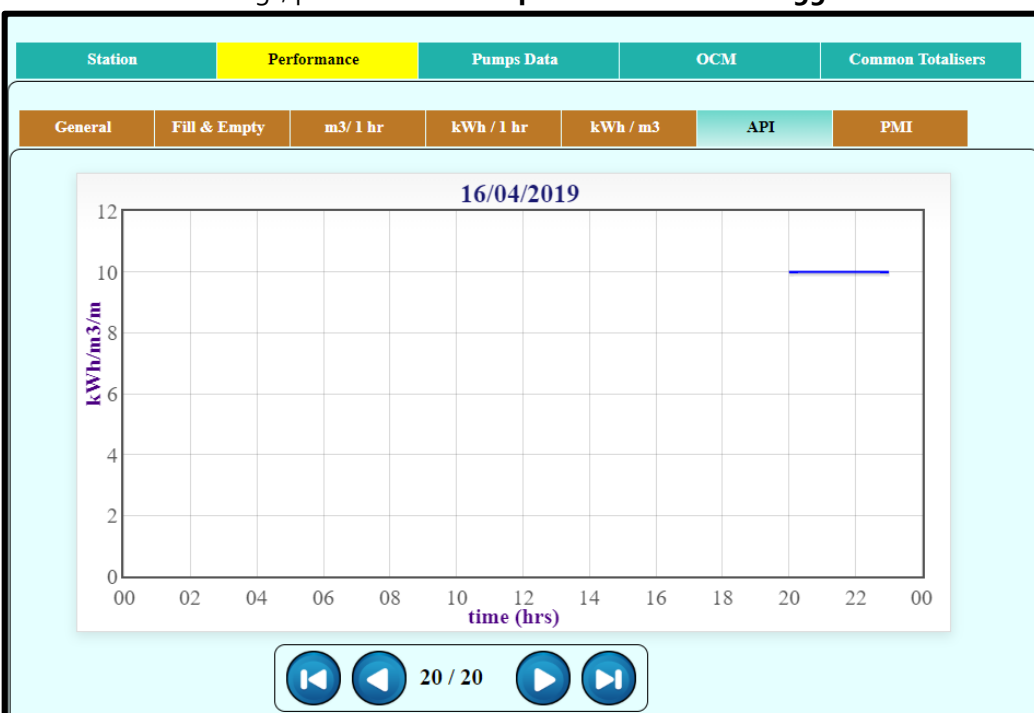

Station PMI Webpage

The information contained on this page provides details of the daily performance of the selected pump and allow viewing of its continued performance over a time period. This information will help to identify at an early stage, to reduce inconvenience on site, when a pump requires maintenance. For more information on Station PMI logs, please refer to **Chapter 7 – section 7.2 Logged Performance**.

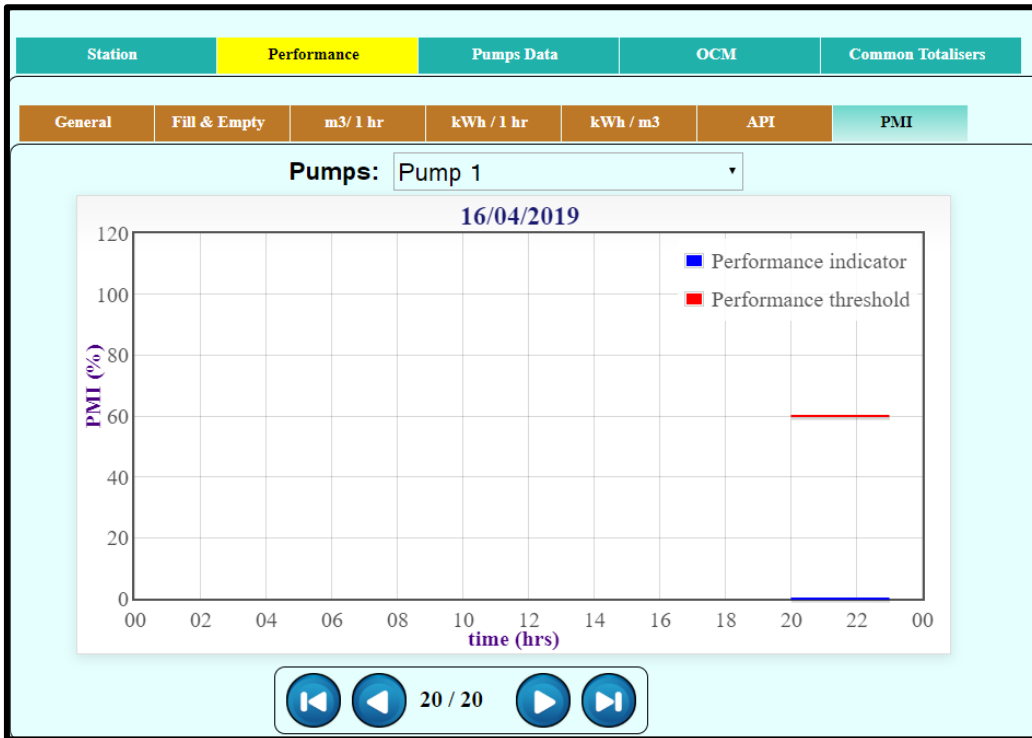

Pumps Data Webpage

This page displays the performance data of all pumps that are programmed and monitored by the Ultimate. For more information on Performance logs, please refer to **Chapter 7 – section 7.2 Logged Performance**.

Station		Performance		Pumps Data			OCM		Common Totalisers		
Pump Name	Starts this week	RunTime this week (hrs)	Total kWh used this week	kWh / m3	Pump Eff.	Demoted count	Reverse count	Blockages count	Total trips	Failed duration (min)	Storm Disable count
Pump 1	4	35.18	0	0	0	0	0	0	0	0	0
Pump 2	5	38.27	0	0	0	0	0	0	0	0	0

OCM Webpage

This page allows you to view the system, resettable, daily and ten-day totaliser information of the current OCM profile(s) setup in the Ultimate. The information on this page is read only, and the totalisers can only be reset on the Ultimate itself.

Station	Performance	Pumps Data	OCM	Common Totalisers																																								
<table border="1"> <thead> <tr> <th>Name</th> <th>Totaliser units</th> <th>Totalisers</th> <th colspan="2">10 Day Totalisers</th> </tr> </thead> <tbody> <tr> <td rowspan="10">OCM 1</td> <td rowspan="10">litre *1</td> <td rowspan="10"> <table border="1"> <thead> <tr> <th>Type</th> <th>Totaliser</th> </tr> </thead> <tbody> <tr> <td>System</td> <td>133802184.00</td> </tr> <tr> <td>Resettable</td> <td>133802184.00</td> </tr> <tr> <td>Daily</td> <td>389469.31</td> </tr> </tbody> </table> </td> <td colspan="2"> <table border="1"> <thead> <tr> <th>Date</th> <th>Totaliser</th> </tr> </thead> <tbody> <tr> <td>18-04-2019</td> <td>389469.31</td> </tr> <tr> <td>17-04-2019</td> <td>7113830.50</td> </tr> <tr> <td>16-04-2019</td> <td>2283495.50</td> </tr> <tr> <td>11-04-2019</td> <td>7541516.5</td> </tr> <tr> <td>10-04-2019</td> <td>7542561.50</td> </tr> <tr> <td>09-04-2019</td> <td>7539092.50</td> </tr> <tr> <td>08-04-2019</td> <td>7540545.00</td> </tr> <tr> <td>07-04-2019</td> <td>7549400.00</td> </tr> <tr> <td>06-04-2019</td> <td>7550002.50</td> </tr> <tr> <td>05-04-2019</td> <td>7542225.00</td> </tr> </tbody> </table> </td> </tr> </tbody> </table>					Name	Totaliser units	Totalisers	10 Day Totalisers		OCM 1	litre *1	<table border="1"> <thead> <tr> <th>Type</th> <th>Totaliser</th> </tr> </thead> <tbody> <tr> <td>System</td> <td>133802184.00</td> </tr> <tr> <td>Resettable</td> <td>133802184.00</td> </tr> <tr> <td>Daily</td> <td>389469.31</td> </tr> </tbody> </table>	Type	Totaliser	System	133802184.00	Resettable	133802184.00	Daily	389469.31	<table border="1"> <thead> <tr> <th>Date</th> <th>Totaliser</th> </tr> </thead> <tbody> <tr> <td>18-04-2019</td> <td>389469.31</td> </tr> <tr> <td>17-04-2019</td> <td>7113830.50</td> </tr> <tr> <td>16-04-2019</td> <td>2283495.50</td> </tr> <tr> <td>11-04-2019</td> <td>7541516.5</td> </tr> <tr> <td>10-04-2019</td> <td>7542561.50</td> </tr> <tr> <td>09-04-2019</td> <td>7539092.50</td> </tr> <tr> <td>08-04-2019</td> <td>7540545.00</td> </tr> <tr> <td>07-04-2019</td> <td>7549400.00</td> </tr> <tr> <td>06-04-2019</td> <td>7550002.50</td> </tr> <tr> <td>05-04-2019</td> <td>7542225.00</td> </tr> </tbody> </table>		Date	Totaliser	18-04-2019	389469.31	17-04-2019	7113830.50	16-04-2019	2283495.50	11-04-2019	7541516.5	10-04-2019	7542561.50	09-04-2019	7539092.50	08-04-2019	7540545.00	07-04-2019	7549400.00	06-04-2019	7550002.50	05-04-2019	7542225.00
Name	Totaliser units	Totalisers	10 Day Totalisers																																									
OCM 1	litre *1	<table border="1"> <thead> <tr> <th>Type</th> <th>Totaliser</th> </tr> </thead> <tbody> <tr> <td>System</td> <td>133802184.00</td> </tr> <tr> <td>Resettable</td> <td>133802184.00</td> </tr> <tr> <td>Daily</td> <td>389469.31</td> </tr> </tbody> </table>	Type	Totaliser	System	133802184.00	Resettable	133802184.00	Daily				389469.31	<table border="1"> <thead> <tr> <th>Date</th> <th>Totaliser</th> </tr> </thead> <tbody> <tr> <td>18-04-2019</td> <td>389469.31</td> </tr> <tr> <td>17-04-2019</td> <td>7113830.50</td> </tr> <tr> <td>16-04-2019</td> <td>2283495.50</td> </tr> <tr> <td>11-04-2019</td> <td>7541516.5</td> </tr> <tr> <td>10-04-2019</td> <td>7542561.50</td> </tr> <tr> <td>09-04-2019</td> <td>7539092.50</td> </tr> <tr> <td>08-04-2019</td> <td>7540545.00</td> </tr> <tr> <td>07-04-2019</td> <td>7549400.00</td> </tr> <tr> <td>06-04-2019</td> <td>7550002.50</td> </tr> <tr> <td>05-04-2019</td> <td>7542225.00</td> </tr> </tbody> </table>		Date	Totaliser	18-04-2019	389469.31	17-04-2019	7113830.50	16-04-2019	2283495.50	11-04-2019	7541516.5	10-04-2019	7542561.50	09-04-2019	7539092.50	08-04-2019	7540545.00	07-04-2019	7549400.00	06-04-2019	7550002.50	05-04-2019	7542225.00							
			Type	Totaliser																																								
			System	133802184.00																																								
			Resettable	133802184.00																																								
			Daily	389469.31																																								
			Date	Totaliser																																								
			18-04-2019	389469.31																																								
			17-04-2019	7113830.50																																								
			16-04-2019	2283495.50																																								
			11-04-2019	7541516.5																																								
10-04-2019	7542561.50																																											
09-04-2019	7539092.50																																											
08-04-2019	7540545.00																																											
07-04-2019	7549400.00																																											
06-04-2019	7550002.50																																											
05-04-2019	7542225.00																																											





Common Totalisers Webpage

This page allows you to view the enable the setup of general flow totalisers, where you can log totalised flow rate hourly, daily, weekly, monthly and yearly, in the desired **totaliser measurement unit**. The Ultimate will also store a log of the last ten days totalised flow

Station	Performance	Pumps Data	OCM	Common Totalisers																											
<table border="1"> <thead> <tr> <th>Name</th> <th>Totaliser units</th> <th>Totalisers</th> <th colspan="2">10 Day Totalisers</th> </tr> </thead> <tbody> <tr> <td rowspan="8">Tot. 1</td> <td rowspan="8">litre *1</td> <td colspan="2"> <table border="1"> <thead> <tr> <th>Type</th> <th>Totaliser</th> </tr> </thead> <tbody> <tr> <td>Hourly</td> <td>0.00</td> </tr> <tr> <td>Daily</td> <td>0.00</td> </tr> <tr> <td>Weekly</td> <td>0.00</td> </tr> <tr> <td>Monthly</td> <td>0.00</td> </tr> <tr> <td>Yearly</td> <td>0.00</td> </tr> <tr> <td>System</td> <td>0.00</td> </tr> <tr> <td>Resettable</td> <td>0.00</td> </tr> </tbody> </table> </td> <td colspan="2">No Totaliser data</td> </tr> </tbody> </table>					Name	Totaliser units	Totalisers	10 Day Totalisers		Tot. 1	litre *1	<table border="1"> <thead> <tr> <th>Type</th> <th>Totaliser</th> </tr> </thead> <tbody> <tr> <td>Hourly</td> <td>0.00</td> </tr> <tr> <td>Daily</td> <td>0.00</td> </tr> <tr> <td>Weekly</td> <td>0.00</td> </tr> <tr> <td>Monthly</td> <td>0.00</td> </tr> <tr> <td>Yearly</td> <td>0.00</td> </tr> <tr> <td>System</td> <td>0.00</td> </tr> <tr> <td>Resettable</td> <td>0.00</td> </tr> </tbody> </table>		Type	Totaliser	Hourly	0.00	Daily	0.00	Weekly	0.00	Monthly	0.00	Yearly	0.00	System	0.00	Resettable	0.00	No Totaliser data	
Name	Totaliser units	Totalisers	10 Day Totalisers																												
Tot. 1	litre *1	<table border="1"> <thead> <tr> <th>Type</th> <th>Totaliser</th> </tr> </thead> <tbody> <tr> <td>Hourly</td> <td>0.00</td> </tr> <tr> <td>Daily</td> <td>0.00</td> </tr> <tr> <td>Weekly</td> <td>0.00</td> </tr> <tr> <td>Monthly</td> <td>0.00</td> </tr> <tr> <td>Yearly</td> <td>0.00</td> </tr> <tr> <td>System</td> <td>0.00</td> </tr> <tr> <td>Resettable</td> <td>0.00</td> </tr> </tbody> </table>		Type	Totaliser	Hourly	0.00	Daily	0.00			Weekly	0.00	Monthly	0.00	Yearly	0.00	System	0.00	Resettable	0.00	No Totaliser data									
		Type	Totaliser																												
		Hourly	0.00																												
		Daily	0.00																												
		Weekly	0.00																												
		Monthly	0.00																												
		Yearly	0.00																												
		System	0.00																												
Resettable	0.00																														

CHAPTER 9 TROUBLESHOOTING

This section describes certain symptoms and provides suggestions on remedial actions. Some actions may involve changing parameters which deal with the ultrasonic level recognition algorithm and associated filters. Adjustments to these parameters are made through the echo profile screen in run mode.

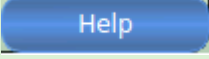
CONTROL/PARAMETER	FUNCTION
	Logs out of direct parameter access mode
	Closes the Parameter Access window without logging off. This negates the need to logon/off when swapping between the Parameter Access window and the echo trace screen (to view the effects of parameter changes).
Par	Enter parameter number to view / edit
Value	Shows the parameter value. The value in the box can be edited to allow writing of parameters.
	Reads the parameter number in the Par box and reports the value in the Value box. A description and value range will be given below the Par box
	Writes the value in the Value box, to the Parameter number in the Par box. A message will be shown to indicate if the parameter write was successful.
	Displays a table of available service parameters and their parameter numbers. Service parameters should only be adjusted under guidance of Pulsar. A full list and description of service parameters can be found in the separate service manual.

To read a parameter



Edit the **Par** to show the parameter number to be read and press

To change a parameter value

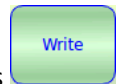

With **Par** showing parameter number to be changed, edit the **Value** box to the desired value and press

Transducer voltage check

Pulsar dB transducers operate over low power DC voltages. The voltages can be measured using a voltmeter to verify any cable extensions, or for fault finding purposes.

The voltages are sourced at the Ultimate controller (or I/O expansion board if connected) and should be present if the transducer is connected or not.

The voltages should be measured with respect to the 0v (Gnd) transducer terminal: -

Power (red transducer wire) 19-24 VDC

Sig (white transducer wire) 5-5.7 VDC

APPENDIX A – DYNAMIC PARAMETER MEMORY MAP

The following registers are used to set up Logical outputs on the Ultimate, details on how to do this can be found in **Chapter 4.15 Logical Output**. The below are Dynamic parameters and are 'Read only'. The RS485 address is equivalent to the index number multiplied by 30,000 i.e., **30xxx** where xxx is the index number.

INDEX	DESCRIPTION	UNIT	MIN	MAX	DEF
0-5	MEMORY FLAGS				
0	"memory status flag"	U_NO	0	999999	0
1	"memory update flag"	U_NO	0	999999	0
2	"inifile status flag"	U_NO	0	999999	0
3	"modem info D"	U_NO	0	999999	0
4	"modem info R"	U_NO	0	999999	0
5	"modem info H"	U_NO	0	999999	0
6-19	GENERAL INFO				
6	"number of IFB"	U_NO	0	4	1
7	"number of transducers"	U_NO	0	8	2
8	"number of analog inputs"	U_NO	0	8	2
9	"number of analog outputs"	U_NO	0	8	2
10	"number of digital inputs"	U_NO	0	32	8
11	"number of measurement points"	U_NO	0	32	1
12	"number of pumps"	U_NO	0	32	0
13	"number of alarms"	U_NO	0	32	0
14	"number of controls"	U_NO	0	32	0
15	"number of miscellaneous"	U_NO	0	32	0
16	"number of logics"	U_NO	0	32	0
17	"number of logical relays"	U_NO	0	20	0
18	"hcds flags"	U_NO	0	65535	0
20-89	STATION INFO				
20	"total num of pumps"	U_NO	0	32	0
21	"num of fault pumps"	U_NO	0	32	0
22	"num of demoted pumps"	U_NO	0	32	0
23	"pump faults duration"	U_NO	0	32	0
24	"num of mains faults"	U_NO	0	999999	0
25	"num of dc faults"	U_NO	0	999999	0
26	"num of xdr faults"	U_NO	0	999999	0
27	"analog input faults"	U_NO	0	999999	0
28	"backup operation is active"	U_NO	0	1	0
29	"hi level alarm is operating"	U_NO	0	1	0
30	"hi hi level alarm is operating"	U_NO	0	1	0
31	"lo level alarm is operating"	U_NO	0	1	0
32	"lo lo level alarm is operating"	U_NO	0	1	0
33	"storm disable pump is operating"	U_NO	0	1	0
34	"overspill is operating"	U_NO	0	1	0
35	"tariff management is operating"	U_NO	0	1	0
36	"pump blocked is active"	U_NO	0	1	0
37	"pump burst is active"	U_NO	0	1	0
38	"num of valid log ons"	U_NO	0	999999	0
39	"num of invalid log ons"	U_NO	0	999999	0
40	"operating times in hours"	U_MN	0	999999	0
41	"total num of pump starts"	U_NO	0	999999	0
42	"total pump run time"	U_MN	0	999999	0
43	"num of rma blocks detected"	U_NO	0	999999	0
44	"num of rma burst detected"	U_NO	0	999999	0
45	"num of retroflo pump reversals"	U_NO	0	999999	0
46	"num of storm disable"	U_NO	0	999999	0

INDEX	DESCRIPTION	UNIT	MIN	MAX	DEF
47	"num of storm detected"	U_NO	0	999999	0
48	"total pumped volume"	U_VU	0	999999	0
49	"total kWh used"	U_KW	0	999999	0
50	"system totaliser"	U_VU	0	999999	0
51	"resettable totaliser"	U_VU	0	999999	0
52	"daily totaliser"	U_VU	0	999999	0
53	"time to spill"	U_VU	0	999999	0
54	"overflow duration"	U_MN	0	999999	0
55	"num of spill counts"	U_NO	0	999999	0
56	"num of fill cycles this week"	U_NO	0	999999	0
57	"average fill time this week"	U_MN	0	999999	0
58	"num of empty cycles this week"	U_NO	0	999999	0
59	"average empty time this week"	U_NO	0	999999	0
60	"num of alarm starts"	U_NO	0	999999	0
61	"num of alarm starts this week"	U_NO	0	999999	0
62	"num of control starts"	U_NO	0	999999	0
63	"num of control starts this week"	U_NO	0	999999	0
64	"num of misc starts"	U_NO	0	999999	0
65	"num of misc starts this week"	U_NO	0	999999	0
66	"num of pump starts this week"	U_NO	0	999999	0
67	"num of pump starts last week"	U_NO	0	999999	0
68	"total pump runtime this week"	U_MN	0	999999	0
69	"total pump runtime last week"	U_MN	0	999999	0
70	"num of fill cycles last week"	U_NO	0	999999	0
71	"average fill time last week"	U_MN	0	999999	0
72	"num of empty cycles last week"	U_NO	0	999999	0
73	"average empty time last week"	U_MN	0	999999	0
74	"num of alarm starts last week"	U_NO	0	999999	0
75	"num of control starts last week"	U_NO	0	999999	0
76	"num of misc starts last week"	U_NO	0	999999	0
77	"total pumped volume last week"	U_VU	0	999999	0
78	"total kWh last week"	U_KW	0	999999	0
79	"station API"	U_PC	0	100	0
80	"mains fault active"	U_NO	0	1	0
81	"dc fault active"	U_NO	0	1	0
82	"dc fault low active"	U_NO	0	1	0
83	"pump is running on"	U_NO	0	1	0
84	"num of retroflo blocks detected"	U_NO	0	999999	0
85	"next pump to start"	U_NO	0	99	0
86	pump exercising"	U_NO	0	1	0
87	"maintenance mode active"	U_NO	0	1	0
88	"maintenance mode timer"	U_MN	0	999999	0
90-109	SUMP LEVEL				
90	"inflow rate"	U_FLO	0	999999	0
91	"sum level"	U_MU	0	999999	0
92	"sum level percent"	U_PC	0	100	0
93	"sum volume"	U_VU	0	999999	0
94	"sum volume percent"	U_PC	0	100	0
95	"linear unit"	U_NO	0	5	0
96	"flow unit"	U_NO	0	10	0
97	"volume unit"	U_NO	0	9	0
98	"wet weather active"	U_NO	0	1	0
99	"wet weather timeout warning"	U_NO	0	1	0
100	"percentage overspill reached"	U_NO	0	1	0

INDEX	DESCRIPTION	UNIT	MIN	MAX	DEF
101	"multiple pumps"	U_NO	0	4	0
102	"multiple pumps failed"	U_NO	0	1	0
103	"multiple pumps unavailable/failed"	U_NO	0	1	0
104	"multiple pumps unavailable"	U_NO	0	1	0
105	"multiple pumps auto"	U_NO	0	1	0
106	"pump station overloaded"	U_NO	0	1	0
107	"pumping station"	U_NO	0	3	0
110-119	Transducer 1 & 2				
110	"xdr 1 status"	U_NO	0	3	0
111	" xdr 1 confidence"	U_PC	0	100	0
112	"xdr 1 temperature"	U_TP	-50	150	0
113	"xdr1 echo strength"	U_DB	0	100	0
114	"xdr 1 noise level"	U_DB	0	100	0
115	"xdr 2 status"	U_NO	0	3	0
116	"xdr 2 confidence"	U_PC	0	100	0
117	"xdr 2 temperature"	U_TP	-50	150	0
118	"xdr 2 echo strength"	U_DB	0	100	0
119	"xdr 2 noise level"	U_DB	0	100	0
120-129	TRANSDUCER 3 & 4				
130-139	TRANSDUCER 5 & 6				
140-149	TRANSDUCER 7 & 8				
150-159	ANALOG INPUT 1				
150	"mA input 1 value"	U_MA	0	25	0
151	"mA input 1 status"	U_NO	0	7	0
152	"mA input 1 rate"	U_NO	-999999	999999	0
153	"ma input 1 under range"	U_NO	0	1	0
154	"ma input 1 over range"	U_NO	0	1	0
160-169	ANALOG INPUT 2				
170-179	ANALOG INPUT 3				
180-189	ANALOG INPUT 4				
190-199	ANALOG INPUT 5				
200-209	ANALOG INPUT 6				
210-219	ANALOG INPUT 7				
220-229	ANALOG INPUT 8				
230-239	ANALOG OUTPUT 1				
230	"mAOut 1 value"	U_MA	0	25	0
231	"mAOut 1 High Level"	U_MU	-999999	999999	0
232	"mAOut 1 Low level"	U_MU	-999999	999999	0
240-249	ANALOG OUTPUT 2				
250-259	ANALOG OUTPUT 3				
260-269	ANALOG OUTPUT 4				
270-279	ANALOG OUTPUT 5				
280-289	ANALOG OUTPUT 6				
290-299	ANALOG OUTPUT 7				
300-309	ANALOG OUTPUT 8				
310-341	DIGITAL INPUTS				
310	"Digital input 1 value"	U_NO	0	1	0
311	"Digital input 2 value"	U_NO	0	1	0
312	"Digital input 3 value"	U_NO	0	1	0
313	"Digital input 4 value"	U_NO	0	1	0
314	"Digital input 5 value"	U_NO	0	1	0
315	"Digital input 6 value"	U_NO	0	1	0
316	"Digital input 7 value"	U_NO	0	1	0

INDEX	DESCRIPTION	UNIT	MIN	MAX	DEF
317	"Digital input 8 value"	U_NO	0	1	0
318	"Digital input 9 value"	U_NO	0	1	0
319	"Digital input 10 value"	U_NO	0	1	0
320	"Digital input 11 value"	U_NO	0	1	0
321	"Digital input 12 value"	U_NO	0	1	0
322	"Digital input 13 value"	U_NO	0	1	0
323	"Digital input 14 value"	U_NO	0	1	0
324	"Digital input 15 value"	U_NO	0	1	0
325	"Digital input 16 value"	U_NO	0	1	0
326	"Digital input 17 value"	U_NO	0	1	0
327	"Digital input 18 value"	U_NO	0	1	0
328	"Digital input 19 value"	U_NO	0	1	0
317	"Digital input 8 value"	U_NO	0	1	0
318	"Digital input 9 value"	U_NO	0	1	0
319	"Digital input 10 value"	U_NO	0	1	0
320	"Digital input 11 value"	U_NO	0	1	0
321	"Digital input 12 value"	U_NO	0	1	0
322	"Digital input 13 value"	U_NO	0	1	0
323	"Digital input 14 value"	U_NO	0	1	0
324	"Digital input 15 value"	U_NO	0	1	0
325	"Digital input 16 value"	U_NO	0	1	0
326	"Digital input 17 value"	U_NO	0	1	0
327	"Digital input 18 value"	U_NO	0	1	0
328	"Digital input 19 value"	U_NO	0	1	0
329	"Digital input 20 value"	U_NO	0	1	0
330	"Digital input 21 value"	U_NO	0	1	0
331	"Digital input 22 value"	U_NO	0	1	0
332	"Digital input 23 value"	U_NO	0	1	0
333	"Digital input 24 value"	U_NO	0	1	0
334	"Digital input 25 value"	U_NO	0	1	0
335	"Digital input 26 value"	U_NO	0	1	0
336	"Digital input 27 value"	U_NO	0	1	0
337	"Digital input 28 value"	U_NO	0	1	0
338	"Digital input 29 value"	U_NO	0	1	0
339	"Digital input 30 value"	U_NO	0	1	0
340	"Digital input 31 value"	U_NO	0	1	0
341	"Digital input 32 value"	U_NO	0	1	0
342	"Digital input 33 value"	U_NO	0	1	0
343	"Digital input 34 value"	U_NO	0	1	0
344	"Digital input 35 value"	U_NO	0	1	0
345	"Digital input 36 value"	U_NO	0	1	0
346	"Digital input 37 value"	U_NO	0	1	0
347	"Digital input 38 value"	U_NO	0	1	0
348	"Digital input 39 value"	U_NO	0	1	0
349	"Digital input 40 value"	U_NO	0	1	0
350-409	PUMP 1				
350	"relay status"	U_NO	0	1	0
351	"manual on"	U_NO	0	1	0
352	"manual off"	U_NO	0	1	0
353	"pump tripped"	U_NO	0	1	0
354	"trip counter"	U_NO	0	999999	0
355	"pump demoted"	U_NO	0	1	0
356	"failed time"	U_MN	0	999999	0
357	"demoted count"	U_NO	0	999999	0
358	"pump blocked is active"	U_NO	0	1	0

INDEX	DESCRIPTION	UNIT	MIN	MAX	DEF
359	"blockage count"	U_NO	0	999999	0
360	"auto reversing is active"	U_NO	0	1	0
361	"auto reversing count"	U_NO	0	999999	0
362	"pump out of service count"	U_NO	0	999999	0
363	"out of service"	U_NO	0	1	0
364	"num of starts"	U_NO	0	999999	0
365	"num starts per interval"	U_NO	0	999999	0
366	"num starts this week"	U_NO	0	999999	0
367	"num run ons"	U_NO	0	999999	0
368	"num exercises"	U_NO	0	999999	0
369	"total run time"	U_MN	0	999999	0
370	"total run time this week"	U_MN	0	999999	0
371	"total kWh used"	U_KW	0	999999	0
372	"calibrated kWh/m3"	U_NO	0	999999	0
373	"efficiency"	U_PC	0	100	0
374	"total pumped volume"	U_VU	0	999999	0
375	"pumped volume this week"	U_VU	0	999999	0
376	"storm disable count"	U_NO	0	999999	0
377	"out of service count"	U_NO	0	999999	0
378	"pump throughput"	U_FLO	0	999999	0
379	"pump rate"	U_FLO	0	999999	0
380	"pump energy efficient"	U_NO	0	999999	0
381	"phase A voltage"	U_VOLT	0	500	0
382	"phase B voltage"	U_VOLT	0	500	0
383	"phase C voltage"	U_VOLT	0	500	0
384	"phase A current"	U_CURR	0	300	0
385	"phase B current"	U_CURR	0	300	0
386	"phase C current"	U_CURR	0	300	0
387	"phase A power factor"	U_NO	0	1	0
388	"phase B power factor"	U_NO	0	1	0
389	"phase C power factor"	U_NO	0	1	0
390	"IRT resistance"	U_NO	0	999999	0
391	"apparent power"	U_KW	0	999999	0
392	"real power"	U_KW	0	999999	0
393	"pump setpoint 1"	U_NO	0	999999	0
394	"pump setpoint 2"	U_NO	0	999999	0
395	"pump setpoint 3"	U_NO	0	999999	0
396	"pump setpoint 4"	U_NO	0	999999	0
397	"pump duty"	U_NO	0	999999	0
398	"pump auto control"	U_MN	0	999999	0
399	"power factor control"	U_VU	0	999999	0
400	"total kWh last week"	U_KW	0	999999	0
401	"total kWh/m3 last week"	U_NO	0	999999	0
402	"efficiency last week"	U_PC	0	100	0
403	"under current"	U_NO	0	1	0
404	"over current"	U_NO	0	1	0
405	"reversal counter"	U_NO	0	999999	0
406	"num of retroflo clearance"	U_NO	0	999999	0
407	"instantaneous kWh/m3"	U_NO	0	999999	0
408	"pump PMI"	U_PC	0	100	100
409	"remote forced setting"	U_NO	0	5	0
410-469	PUMP 2				
470-529	PUMP 3				

INDEX	DESCRIPTION	UNIT	MIN	MAX	DEF
530-589	PUMP 4				
590-649	PUMP 5				
650-709	PUMP 6				
710-769	PUMP 7				
770-829	PUMP 8				
830-889	PUMP 9				
890-949	PUMP 10				
950-1009	PUMP 11				
1010-1069	PUMP 12				
1070-1129	PUMP 13				
1130-1189	PUMP 14				
1190-1249	PUMP 15				
1250-1309	PUMP 16				
1310-1369	PUMP 17				
1370-1429	PUMP 18				
1430-1489	PUMP 19				
1490-1549	PUMP 20				
1550-1609	PUMP 21				
1610-1669	PUMP 22				
1670-1729	PUMP 23				
1730-1789	PUMP 24				
1790-1849	PUMP 25				
1850-1909	PUMP 26				
1910-1969	PUMP 27				
1970-2029	PUMP 28				
2030-2089	PUMP 29				
2090-2149	PUMP 30				
2150-2209	PUMP 31				
2210-2269	PUMP 32				
2270-2279	ALARM 1				
2270	"relay status"	U_NO	0	1	0
2271	"num relay closures"	U_NO	0	999999	0
2272	"setpoint 1"	U_NO	0	999999	0
2273	"setpoint 2"	U_NO	0	999999	0
2274	"setpoint 3"	U_NO	0	999999	0
2275	"setpoint 4"	U_NO	0	999999	0
2280-2289	ALARM 2				
2290-2299	ALARM 3				
2300-2309	ALARM 4				
2310-2319	ALARM 5				
2320-2329	ALARM 6				
2330-2339	ALARM 7				
2340-2349	ALARM 8				
2350-2359	ALARM 9				
2360-2369	ALARM 10				
2370-2379	ALARM 11				
2380-2389	ALARM 12				
2390-2399	ALARM 13				
2400-2409	ALARM 14				
2410-2419	ALARM 15				
2420-2429	ALARM 16				
2430-2439	ALARM 17				
2440-2449	ALARM 18				

INDEX	DESCRIPTION	UNIT	MIN	MAX	DEF
2500-2509	ALARM 24				
2510-2519	ALARM 25				
2520-2529	ALARM 26				
2530-2539	ALARM 27				
2540-2549	ALARM 28				
2550-2559	ALARM 29				
2560-2569	ALARM 30				
2570-2579	ALARM 31				
2580-2589	ALARM 32				
2590-2599	CONTROL 1				
1130-1189	PUMP 14				
1190-1249	PUMP 15				
1250-1309	PUMP 16				
1310-1369	PUMP 17				
1370-1429	PUMP 18				
1430-1489	PUMP 19				
1490-1549	PUMP 20				
1550-1609	PUMP 21				
1610-1669	PUMP 22				
1670-1729	PUMP 23				
1730-1789	PUMP 24				
1790-1849	PUMP 25				
1850-1909	PUMP 26				
1910-1969	PUMP 27				
1970-2029	PUMP 28				
2030-2089	PUMP 29				
2090-2149	PUMP 30				
2150-2209	PUMP 31				
2210-2269	PUMP 32				
2270-2279	ALARM 1				
2590	"relay status"	U_NO	0	1	0
2591	"num relay closures"	U_NO	0	999999	0
2592	"setpoint 1"	U_NO	0	999999	0
2593	"setpoint 2"	U_NO	0	999999	0
2594	"setpoint 3"	U_NO	0	999999	0
2595	"setpoint 4"	U_NO	0	999999	0
2600-2609	CONTROL 2				
2610-2619	CONTROL 3				
2620-2629	CONTROL 4				
2630-2639	CONTROL 5				
2640-2649	CONTROL 6				
2650-2659	CONTROL 7				
2660-2669	CONTROL 8				
2670-2679	CONTROL 9				
2680-2689	CONTROL 10				
2690-2699	CONTROL 11				
2700-2709	CONTROL 12				
2710-2709	CONTROL 13				
2720-2729	CONTROL 14				
2730-2739	CONTROL 15				
2740-2749	CONTROL 16				
2750-2759	CONTROL 17				
2760-2769	CONTROL 18				
2770-2779	CONTROL 19				

INDEX	DESCRIPTION	UNIT	MIN	MAX	DEF
2780-2789	CONTROL 20				
2790-2799	CONTROL 21				
2800-2809	CONTROL 22				
2810-2819	CONTROL 23				
2820-2829	CONTROL 24				
2830-2839	CONTROL 25				
2840-2849	CONTROL 26				
2850-2859	CONTROL 27				
2860-2869	CONTROL 28				
2870-2879	CONTROL 29				
2880-2889	CONTROL 30				
2910-2919	MISC 1				
2910	"relay status"	U_NO	0	1	0
2911	"num relay closures"	U_NO	0	999999	0
2912	"setpoint 1"	U_NO	0	999999	0
2913	"setpoint 2"	U_NO	0	999999	0
2914	"setpoint 3"	U_NO	0	999999	0
2915	"setpoint 4"	U_NO	0	999999	0
2920-2929	MISC 2				
2930-2939	MISC 3				
2940-2949	MISC 4				
2950-2959	MISC 5				
2960-2969	MISC 6				
2970-2979	MISC 7				
2980-2989	MISC 8				
2990-2999	MISC 9				
3000-3009	MISC 10				
3010-3019	MISC 11				
3020-3029	MISC 12				
3030-3039	MISC 13				
3040-3049	MISC 14				
3050-3059	MISC 15				
3060-3069	MISC 16				
3070-3079	MISC 17				
3080-3089	MISC 18				
3090-3099	MISC 19				
3100-3109	MISC 20				
3110-3119	MISC 21				
3120-3129	MISC 22				
3130-3139	MISC 23				
3140-3149	MISC 24				
3150-3159	MISC 25				
3160-3169	MISC 26				
3170-3179	MISC 27				
3180-3189	MISC 28				
3190-3199	MISC 29				
3200-3209	MISC 30				
3210-3219	MISC 31				
3220-3229	MISC 32				
3230-3239	MEASUREMENT POINT 1				
3230	"out"	U_NO	-999999	999999	0
3231	"out percent"	U_NO	-100	100	0
3232	"rate"	U_NO	-999999	999999	0

INDEX	DESCRIPTION	UNIT	MIN	MAX	DEF
3233	"strength"	U_NO	0	999999	0
3234	"confidence"	U_NO	0	100	0
3235	"temperature"	U_NO	-200	200	0
3236	"status ok"	U_NO	0	1	0
3237	"phase voltage AB"	U_VOLT	0	99999	0
3238	"phase voltage BC"	U_VOLT	0	99999	0
3239	"phase voltage AC"	U_VOLT	0	99999	0
3240-3249	MEASUREMENTS POINT 2				
3250-3259	MEASUREMENTS POINT 3				
3260-3269	MEASUREMENTS POINT 4				
3270-3279	MEASUREMENTS POINT 5				
3280-3289	MEASUREMENTS POINT 6				
3290-3299	MEASUREMENTS POINT 7				
3300-3309	MEASUREMENTS POINT 8				
3310-3319	MEASUREMENTS POINT 9				
3320-3329	MEASUREMENTS POINT 10				
3330-3339	MEASUREMENTS POINT 11				
3340-3349	MEASUREMENTS POINT 12				
3350-3359	MEASUREMENTS POINT 13				
3360-3369	MEASUREMENTS POINT 14				
3370-3379	MEASUREMENTS POINT 15				
3380-3389	MEASUREMENTS POINT 16				
3390-3399	MEASUREMENTS POINT 17				
3400-3409	MEASUREMENTS POINT 18				
3410-3419	MEASUREMENTS POINT 19				
3420-3429	MEASUREMENTS POINT 20				
3430-3439	MEASUREMENTS POINT 21				
3440-3449	MEASUREMENTS POINT 22				
3450-3459	MEASUREMENTS POINT 23				
3460-3469	MEASUREMENTS POINT 24				
3470-3479	MEASUREMENTS POINT 25				
3480-3489	MEASUREMENTS POINT 26				
3490-3499	MEASUREMENTS POINT 27				
3500-3509	MEASUREMENTS POINT 28				
3510-3519	MEASUREMENTS POINT 29				
3520-3529	MEASUREMENTS POINT 30				
3470-3479	MEASUREMENTS POINT 25				
3530-3539	LOGIC POINT 1				
3530	"relay status"	U_NO	0	1	0
3531	"num relay closures"	U_NO	0	99999	0
3532	"min On time"	U_NO	0	99999	0
3533	"start Delay"	U_NO	0	99999	0
3540-3549	LOGIC POINT 2				
3550-3559	LOGIC POINT 3				
3560-3569	LOGIC POINT 4				
3570-3579	LOGIC POINT 5				
3580-3589	LOGIC POINT 6				
3590-3599	LOGIC POINT 7				
3600-3609	LOGIC POINT 8				
3610-3619	LOGIC POINT 9				
3620-3629	LOGIC POINT 10				
3630-3639	LOGIC POINT 11				
3640-3649	LOGIC POINT 12				
3650-3659	LOGIC POINT 13				

INDEX	DESCRIPTION	UNIT	MIN	MAX	DEF
3660-3669	LOGIC POINT 14				
3670-3679	LOGIC POINT 15				
3680-3689	LOGIC POINT 16				
3690-3699	LOGIC POINT 17				
3700-3709	LOGIC POINT 18				
3710-3719	LOGIC POINT 19				
3720-3729	LOGIC POINT 20				
3730-3739	LOGIC POINT 21				
3740-3749	LOGIC POINT 22				
3750-3759	LOGIC POINT 23				
3760-3769	LOGIC POINT 24				
3770-3779	LOGIC POINT 25				
3780-3789	LOGIC POINT 26				
3790-3799	LOGIC POINT 27				
3800-3809	LOGIC POINT 28				
3810-3819	LOGIC POINT 29				
3820-3829	LOGIC POINT 30				
3830-3839	LOGIC POINT 31				
3840-3849	LOGIC POINT 32				
3850-3854	LOGICAL POINT 1				
3850	"out value"	U_NO	0	1	0
3855-3859	LOGICAL POINT 2				
3860-3864	LOGICAL POINT 3				
3865-3869	LOGICAL POINT 4				
3870-3874	LOGICAL POINT 5				
3875-3879	LOGICAL POINT 6				
3880-3884	LOGICAL POINT 7				
3885-3889	LOGICAL POINT 8				
3890-3894	LOGICAL POINT 9				
3895-3899	LOGICAL POINT 10				
3900-3904	LOGICAL POINT 11				
3905-3909	LOGICAL POINT 12				
3910-3914	LOGICAL POINT 13				
3915-3919	LOGICAL POINT 14				
3920-3924	LOGICAL POINT 15				
3925-3929	LOGICAL POINT 16				
3930-3934	LOGICAL POINT 17				
3935-3939	LOGICAL POINT 18				
3940-3944	LOGICAL POINT 19				
3945-3949	LOGICAL POINT 20				
3950-3999	OCM 1				
3950	"calculated flow"	U_NO	0	999999	0
3951	"calculated flow percent"	U_PC	0	100	0
3952	"average head"	U_NO	0	999999	0
3953	"head"	U_MU	0	99999	0
3954	"head percent"	U_PC	0	100	0
3955	"daily tot"	U_NO	0	999999	0
3956	"resettable tot"	U_NO	0	999999	0
3957	"system tot"	U_NO	0	999999	0
3960-3969	OCM 2				
3970-3979	OCM 3				
3980-3989	OCM 4				
3990-3999	OCM 5				

INDEX	DESCRIPTION	UNIT	MIN	MAX	DEF
4000-4049	VOLUME 1				
4000	"calculated volume"	U_NO	0	999999	0
4001	"calculated volume percent"	U_PC	0	100	0
4002	"Max volume"	U_NO	0	999999	0
4003	"user max volume"	U_NO	0	999999	0
4020-4029	VOLUME 3				
4030-4039	VOLUME 4				
4040-4049	VOLUME 5				
4050-4149	GENERAL TOTALISER 1				
4050	"Hourly Totaliser"	U_NO	0	999999	0
4051	"Daily Totaliser"	U_NO	0	999999	0
4052	"Weekly Totaliser"	U_NO	0	999999	0
4053	"Monthly Totaliser"	U_NO	0	999999	0
4054	"Yearly Totaliser"	U_NO	0	999999	0
4055	"Resettable Totaliser"	U_NO	0	999999	0
4056	"System Totaliser"	U_NO	0	999999	0
4050	"Hourly Totaliser"	U_NO	0	999999	0
4051	"Daily Totaliser"	U_NO	0	999999	0
4060-4069	GENERAL TOTALISER 2				
4070-4079	GENERAL TOTALISER 3				
4080-4089	GENERAL TOTALISER 4				
4090-4099	GENERAL TOTALISER 5				
4100-4109	GENERAL TOTALISER 6				
4110-4119	GENERAL TOTALISER 7				
4120-4129	GENERAL TOTALISER 8				
4130-4139	GENERAL TOTALISER 9				
4140-4149	GENERAL TOTALISER 10				
4150-4199	MODEM INFO				
4150	"WAN-1 Connection Status"	U_NO	0	6	0
4151	"WAN-2 Connection Status"	U_NO	0	6	0
4152	"WAN-3 Connection Status"	U_NO	0	6	0
4153	"3G/4G Service Type"	U_NO	0	7	0
4154	"3G/4G Link Status"	U_NO	0	6	0
4155	"3G/4G Signal Strength"	U_NO	0	100	0
4156	"3G/4G SIM Status"	U_NO	0	2	0
4157	"3G/4G MCC"	U_NO	0	999999	0
4158	"3G/4G MNC"	U_NO	0	999999	0
4159	"3G/4G CS Register Status"	U_NO	0	1	0
4160	"3G/4G PS Register Status"	U_NO	0	1	0
4161	"3G/4G Roaming Status"	U_NO	0	1	0
4162	"3G/4G RSSI"	U_NO	0	999999	0
4163	"3G/4G RSRP"	U_NO	0	999999	0
4164	"3G/4G RSRQ"	U_NO	0	999999	0
4165	"ADSL Download Data Rate"	U_NO	0	999999	0
4166	"ADSL Upload Data Rate"	U_NO	0	999999	0
4167	"ADSL SNR Download"	U_DB	0	999999	0
4168	"ADSL SNR Upload"	U_DB	0	999999	0
4169	"ADSL Modem Link Status"	U_NO	0	1	0
4170	"VPN IPSec Tunnel 1 Status"	U_NO	1	9	0
4171	"VPN IPSec Tunnel 2 Status"	U_NO	1	9	0
4172	"VPN IPSec Tunnel 3 Status"	U_NO	1	9	0
4173	"VPN IPSec Tunnel 4 Status"	U_NO	1	9	0
4174	"VPN IPSec Tunnel 5 Status"	U_NO	1	9	0
4175	"VPN IPSec Tunnel 6 Status"	U_NO	1	9	0

INDEX	DESCRIPTION	UNIT	MIN	MAX	DEF
4170	"VPN IPsec Tunnel 1 Status"	U_NO	1	9	0
4171	"VPN IPsec Tunnel 2 Status"	U_NO	1	9	0
4172	"VPN IPsec Tunnel 3 Status"	U_NO	1	9	0
4173	"VPN IPsec Tunnel 4 Status"	U_NO	1	9	0
4174	"VPN IPsec Tunnel 5 Status"	U_NO	1	9	0
4175	"VPN IPsec Tunnel 6 Status"	U_NO	1	9	0
4170	"VPN IPsec Tunnel 1 Status"	U_NO	1	9	0
4171	"VPN IPsec Tunnel 2 Status"	U_NO	1	9	0
4172	"VPN IPsec Tunnel 3 Status"	U_NO	1	9	0
4173	"VPN IPsec Tunnel 4 Status"	U_NO	1	9	0
4174	"VPN IPsec Tunnel 5 Status"	U_NO	1	9	0
4175	"VPN IPsec Tunnel 6 Status"	U_NO	1	9	0
4170	"VPN IPsec Tunnel 1 Status"	U_NO	1	9	0
4171	"VPN IPsec Tunnel 2 Status"	U_NO	1	9	0
4172	"VPN IPsec Tunnel 3 Status"	U_NO	1	9	0
4173	"VPN IPsec Tunnel 4 Status"	U_NO	1	9	0
4174	"VPN IPsec Tunnel 5 Status"	U_NO	1	9	0
4175	"VPN IPsec Tunnel 6 Status"	U_NO	1	9	0
4200-4379	ANALOG INPUT 9				
4200	"mA input 9 value"	U_MA	0	25	0
4201	"mA input 9 status"	U_NO	0	7	0
4202	"mA input 9 rate"	U_NO	-999999	999999	0
4203	"mA input 9 under range"	U_NO	0	1	0
4204	"mA input 9 over range"	U_NO	0	1	0
4210-4219	ANALOG INPUT 10				
4220-4229	ANALOG INPUT 11				
4230-4239	ANALOG INPUT 12				
4240-4249	ANALOG INPUT 13				
4250-4259	ANALOG INPUT 14				
4260-4269	ANALOG INPUT 15				
4270-4279	ANALOG INPUT 16				
4280-4289	ANALOG INPUT 17				
4290-4299	ANALOG INPUT 18				
4300-4309	ANALOG INPUT 19				
4310-4319	ANALOG INPUT 20				
4320-4329	ANALOG INPUT 21				
4330-4339	ANALOG INPUT 22				
4340-4349	ANALOG INPUT 23				
4350-4359	ANALOG INPUT 24				
4360-4369	ANALOG INPUT 25				
4370-4379	ANALOG INPUT 26				
4380-4469	DIGITAL INPUTS				
4380	"Digital input 41 value"	U_NO	0	1	0
4381	"Digital input 42 value"	U_NO	0	1	0
4382	"Digital input 43 value"	U_NO	0	1	0
4383	"Digital input 44 value"	U_NO	0	1	0
4384	"Digital input 45 value"	U_NO	0	1	0
4385	"Digital input 46 value"	U_NO	0	1	0
4386	"Digital input 47 value"	U_NO	0	1	0
4387	"Digital input 48 value"	U_NO	0	1	0
4388	"Digital input 49 value"	U_NO	0	1	0
4389	"Digital input 50 value"	U_NO	0	1	0
4390	"Digital input 51 value"	U_NO	0	1	0
4391	"Digital input 52 value"	U_NO	0	1	0
4392	"Digital input 53 value"	U_NO	0	1	0

INDEX	DESCRIPTION	UNIT	MIN	MAX	DEF
4393	"Digital input 54 value"	U_NO	0	1	0
4394	"Digital input 55 value"	U_NO	0	1	0
4395	"Digital input 56 value"	U_NO	0	1	0
4396	"Digital input 57 value"	U_NO	0	1	0
4397	"Digital input 58 value"	U_NO	0	1	0
4398	"Digital input 59 value"	U_NO	0	1	0
4399	"Digital input 60 value"	U_NO	0	1	0
4400	"Digital input 61 value"	U_NO	0	1	0
4401	"Digital input 62 value"	U_NO	0	1	0
4402	"Digital input 63 value"	U_NO	0	1	0
4403	"Digital input 64 value"	U_NO	0	1	0
4404	"Digital input 65 value"	U_NO	0	1	0
4405	"Digital input 66 value"	U_NO	0	1	0
4406	"Digital input 67 value"	U_NO	0	1	0
4407	"Digital input 68 value"	U_NO	0	1	0
4408	"Digital input 69 value"	U_NO	0	1	0
4409	"Digital input 70 value"	U_NO	0	1	0
4410	"Digital input 71 value"	U_NO	0	1	0
4411	"Digital input 72 value"	U_NO	0	1	0
4412	"Digital input 73 value"	U_NO	0	1	0
4413	"Digital input 74 value"	U_NO	0	1	0
4414	"Digital input 75 value"	U_NO	0	1	0
4415	"Digital input 76 value"	U_NO	0	1	0
4416	"Digital input 77 value"	U_NO	0	1	0
4417	"Digital input 78 value"	U_NO	0	1	0
4418	"Digital input 79 value"	U_NO	0	1	0
4419	"Digital input 80 value"	U_NO	0	1	0
4420	"Digital input 81 value"	U_NO	0	1	0
4421	"Digital input 82 value"	U_NO	0	1	0
4422	"Digital input 83 value"	U_NO	0	1	0
4423	"Digital input 84 value"	U_NO	0	1	0
4424	"Digital input 85 value"	U_NO	0	1	0
4425	"Digital input 86 value"	U_NO	0	1	0
4426	"Digital input 87 value"	U_NO	0	1	0
4427	"Digital input 88 value"	U_NO	0	1	0
4428	"Digital input 89 value"	U_NO	0	1	0
4429	"Digital input 90 value"	U_NO	0	1	0
4430	"Digital input 91 value"	U_NO	0	1	0
4431	"Digital input 92 value"	U_NO	0	1	0
4432	"Digital input 93 value"	U_NO	0	1	0
4433	"Digital input 94 value"	U_NO	0	1	0
4434	"Digital input 95 value"	U_NO	0	1	0
4435	"Digital input 96 value"	U_NO	0	1	0
4436	"Digital input 97 value"	U_NO	0	1	0
4437	"Digital input 98 value"	U_NO	0	1	0
4438	"Digital input 99 value"	U_NO	0	1	0
4439	"Digital input 100 value"	U_NO	0	1	0
4440	"Digital input 101 value"	U_NO	0	1	0
4441	"Digital input 102 value"	U_NO	0	1	0
4442	"Digital input 103 value"	U_NO	0	1	0
4443	"Digital input 104 value"	U_NO	0	1	0
4444	"Digital input 105 value"	U_NO	0	1	0
4445	"Digital input 106 value"	U_NO	0	1	0
4446	"Digital input 107 value"	U_NO	0	1	0

INDEX	DESCRIPTION	UNIT	MIN	MAX	DEF
4447	"Digital input 108 value"	U_NO	0	1	0
4448	"Digital input 109 value"	U_NO	0	1	0
4449	"Digital input 110 value"	U_NO	0	1	0
4450	"Digital input 111 value"	U_NO	0	1	0
4451	"Digital input 112 value"	U_NO	0	1	0
4452	"Digital input 113 value"	U_NO	0	1	0
4453	"Digital input 114 value"	U_NO	0	1	0
4454	"Digital input 115 value"	U_NO	0	1	0
4455	"Digital input 116 value"	U_NO	0	1	0
4456	"Digital input 117 value"	U_NO	0	1	0
4457	"Digital input 118 value"	U_NO	0	1	0
4458	"Digital input 119 value"	U_NO	0	1	0
4459	"Digital input 120 value"	U_NO	0	1	0
4460	"Digital input 121 value"	U_NO	0	1	0
4461	"Digital input 122 value"	U_NO	0	1	0
4462	"Digital input 123 value"	U_NO	0	1	0
4463	"Digital input 124 value"	U_NO	0	1	0
4464	"Digital input 125 value"	U_NO	0	1	0
4465	"Digital input 126 value"	U_NO	0	1	0
4466	"Digital input 127 value"	U_NO	0	1	0
4467	"Digital input 128 value"	U_NO	0	1	0
4470-4479	COUNTER INPUTS				
4470	"Counter input 1"	U_NO	0	65535	0
4471	"Counter input 2"	U_NO	0	65535	0
4472	"Counter input 3"	U_NO	0	65535	0
4473	"Counter input 4"	U_NO	0	65535	0
4474	"Counter input 5"	U_NO	0	65535	0
4475	"Counter input 6"	U_NO	0	65535	0
4476	"Counter input 7"	U_NO	0	65535	0
4477	"Counter input 8"	U_NO	0	65535	0
4478	"Counter input 9"	U_NO	0	65535	0
4490-4489	FREQUENCY INPUTS				
4480	"Frequency input 1"	U_NO	0	65535	0
4481	"Frequency input 2"	U_NO	0	65535	0
4482	"Frequency input 3"	U_NO	0	65535	0
4483	"Frequency input 4"	U_NO	0	65535	0
4484	"Frequency input 5"	U_NO	0	65535	0
4485	"Frequency input 6"	U_NO	0	65535	0
4486	"Frequency input 7"	U_NO	0	65535	0
4487	"Frequency input 8"	U_NO	0	65535	0
4488	"Frequency input 9"	U_NO	0	65535	0

APPENDIX B – ULTIMATE STATIC PARAMETER

The following registers are 'Static parameters' and can be viewed and written to in order to change a value. The RS485 address is equivalent to the index number. To write to an address you will need to remotely log on using index 2400 and enter the passcode for your controller.

The following table shows the unit symbols and their corresponding descriptions:

UNIT	DEFINITION
U_NO	None
U_SE	Seconds
U_MN	Minutes
U_HR	Hours
U_VEL	m/sec
U_MU	System unit
U_PC	Percentage
U_MO	Mega Ohm
U_MV	Millivolt
U_MUS	U_MU/s
U_DB	Decibel
U_TP	Degree C
U_MA	mA
U_VU	Volume unit

PUMPS PERFORMANCE	IDX	UNIT	MIN	MAX	DEF
risingMain	100	U_NO	0	2	0
headPressure	101	U_NO	0	99999	0
allocMeasIndex	102	U_NO	0	31	0
Sg	103	U_NO	0	99999	1
vertSensorLoc	104	U_MU	0	99999	0
LogInterval	105	U_HR	1	720	1
SPEEDT	IDX	UNIT	MIN	MAX	DEF
interval	200	U_SE	3	120	5
autoGain	201	U_NO	0	1	1
highLvlTrigger	202	U_NO	0	1	1
sndVelocity	203	U_VEL	0	99999	1450
minVelocity	204	U_VEL	-6	6	0
maxVelocity	205	U_VEL	-6	6	3
damping	206	U_NO	5	155	5
peakWidth	207	U_NO	0	100	20
minSignalQuality	208	U_NO	0	100	0
permanence	209	U_NO	0	255	20
aSet	210	U_NO	0	550	55
speedyLevel	211	U_MU	0	99999	300
speedCorrection	212	U_NO	0	4	1
termination	213	U_NO	0	1	0

DISPLAY CONTROL	IDX	UNIT	MIN	MAX	DEF
ProgramModeTimeout	300	U_MN	1	9999	30
ScreenSaverEnable	301	U_NO	0	1	0
ScreensaverTimeout	302	U_MN	1	9999	60
IdleBrightness	303	U_NO	0	7	3
traceScreenTimeout	304	U_MN	1	9999	1
BeepEnable	305	U_NO	0	1	1
REMOTE ALARM	IDX	UNIT	Min	Max	def
alarmSMS	400	U_NO	0	1	0
alarmDelay	401	U_SE	0	9999	30
intervalSMS	402	U_MN	0	9999	60
dialInterval	403	U_MN	0	9999	0
dialIndex	404	U_NO	5	3949	92
chkMonday	405	U_NO	0	1	0
chkTuesday	406	U_NO	0	1	0
chkWednesday	407	U_NO	0	1	0
chkThursday	408	U_NO	0	1	0
chkFriday	409	U_NO	0	1	0
chkSaturday	410	U_NO	0	1	0
chkSunday	411	U_NO	0	1	0
startHour	412	U_NO	0	23	0
startMinute	413	U_NO	0	59	0
stopHour	414	U_NO	0	23	23
stopMinute	415	U_NO	0	59	59
POWER CONTROL	IDX	UNIT	MIN	MAX	DEF
DCBackupEnable	500	U_NO	0	1	0
ReportMainsFailed	501	U_NO	0	1	0
ReportDCFailed	502	U_NO	0	1	0
Mainsfaildisablecontrol	503	U_NO	0	1	0
RUN ON	IDX	UNIT	MIN	MAX	DEF
enabled	600	U_NO	0	1	0
RunInterval	601	U_HR	0	99999	0
PrimeLevel	602	U_MU	0	99999	0
RunDuration	603	U_SE	0	99999	0
MinHead	604	U_MU	0	99999	0
BACKUP CONTROL	IDX	UNIT	MIN	MAX	DEF
enabled	700	U_NO	0	2	0
Hialarm1Level	701	U_MU	0	99999	0
Hialarm2Level	702	U_MU	0	99999	0
ControlTime	703	U_SE	0	9999	0
PersistTime	704	U_SE	0	9999	0
WALL CLING & ODOUR REDUCTION	IDX	UNIT	MIN	MAX	DEF
wallClingEnabled	800	U_NO	0	1	0
wallCling MaxBand	801	U_MU	0	99999	0
septicityEnabled	802	U_NO	0	1	0
septicityperiod	803	U_SE	0	99999	60
MinHead	804	U_MU	0	99999	0

PUMP EXERCISE	IDX	UNIT	MIN	MAX	DEF
enabled	900	U_NO	0	1	0
ExerciseTime	901	U_SE	0	99999	30
IdleTime	902	U_MN	0	99999	720
MinHead	903	U_MU	0	99999	0
DISPLAY UNITS	IDX	UNIT	MIN	MAX	DEF
mainLinearUnits	1000	U_NO	0	3	0
mainUnitMode	1001	U_NO	0	1	0
mainDecimals	1002	U_NO	0	3	2
mainOffset	1003	U_NO	99999	99999	0
mainConversionf	1004	U_NO	0	999	1
mainSource	1005	U_NO	0	2	0
mainDselMeasIndx	1006	U_NO	0	31	0
mainD1selApplIndx	1007	U_NO	0	5	0
mainDOperation	1008	U_NO	0	3	0
AUX1Enabled	1009	U_NO	0	1	0
AUX1UnitMode	1010	U_NO	0	1	0
AUX1Decimals	1011	U_NO	0	3	2
AUX1Offset	1012	U_NO	99999	99999	0
AUX1Conversion	1013	U_NO	0	999	1
AUX1Source	1014	U_NO	0	8	0
AUX2Enabled	1015	U_NO	0	1	0
AUX2UnitMode	1016	U_NO	0	1	0
AUX2Decimals	1017	U_NO	0	3	2
AUX2Offset	1018	U_NO	99999	99999	0
AUX2Conversionf	1019	U_NO	0	999	1
AUX2Source	1020	U_NO	0	8	0
FlowDisplayEnable	1021	U_NO	0	1	1
FlowVolumeUnit	1022	U_NO	0	5	1
FlowTimeUnit	1023	U_NO	0	3	0
FlowDecimals	1024	U_NO	0	3	2
OCMVolumeUnit	1025	U_NO	0	5	1
OCMTimeUnit	1026	U_NO	0	3	0
VOLVolumeUnit	1027	U_NO	0	8	1
FAILSAFE	IDX	UNIT	MIN	MAX	DEF
FailTime1	1100	U_SE	0	9999	120
FailMode	1101	U_NO	0	3	0

TARIFF MANAGEMENT (1)	IDX	UNIT	MIN	MAX	DEF
enabled	1200	U_NO	0	1	0
OverflowLevel	1201	U_MU	0	99999	99999
LeadTime	1202	U_MN	0	99999	3
LagTime	1203	U_MN	0	99999	6
MinPumpRun	1204	U_SE	0	99999	60
MinHead	1205	U_MU	0	99999	0
rateValidation	1206	U_PC	0	200	100
Tariff1StartHH	1207	U_HR	0	23	0
Tariff1StartMM	1208	U_MN	0	59	0
Tariff1EndHH	1209	U_HR	0	23	0
Tariff1EndMM	1210	U_MN	0	59	0
repeatDays1	1211	U_NO	0	8	0
repeatWeeks1	1212	U_NO	0	5	0
startDD1	1213	U_NO	1	31	0
startMM1	1214	U_NO	1	12	0
endDD1	1215	U_NO	1	31	0
endMM1	1216	U_NO	1	12	0
Tariff2StartHH	1217	U_HR	0	23	0
Tariff2StartMM	1218	U_MN	0	59	0
Tariff2EndHH	1219	U_HR	0	23	0
Tariff2EndMM	1220	U_MN	0	59	0
repeatDays2	1221	U_NO	0	8	0
repeatWeeks2	1222	U_NO	0	5	0
startDD2	1223	U_NO	1	31	0
startMM2	1224	U_NO	1	12	0
endDD2	1225	U_NO	1	31	0
endMM2	1226	U_NO	1	12	0
Tariff3StartHH	1227	U_HR	0	23	0
Tariff3StartMM	1228	U_MN	0	59	0
Tariff3EndHH	1229	U_HR	0	23	0
Tariff3EndMM	1230	U_MN	0	59	0
repeatDays3	1231	U_NO	0	8	0
repeatWeeks3	1232	U_NO	0	5	0
startDD3	1233	U_NO	1	31	0
startMM3	1234	U_NO	1	12	0
endDD3	1235	U_NO	1	31	0
endMM3	1236	U_NO	1	12	0
Tariff4StartHH	1237	U_HR	0	23	0
Tariff4StartMM	1238	U_MN	0	59	0
Tariff4EndHH	1239	U_HR	0	23	0
Tariff4EndMM	1240	U_MN	0	59	0
repeatDays4	1241	U_NO	0	8	0
repeatWeeks4	1242	U_NO	0	5	0
startDD4	1243	U_NO	1	31	0
startMM4	1244	U_NO	1	12	0
endDD4	1245	U_NO	1	31	0
endMM4	1246	U_NO	1	12	0
Tariff5StartHH	1247	U_HR	0	23	0
Tariff5StartMM	1248	U_MN	0	59	0
Tariff5EndHH	1249	U_HR	0	23	0
Tariff5EndMM	1250	U_MN	0	59	0
repeatDays5	1251	U_NO	0	8	0

TARIFF MANAGEMENT (1)	IDX	UNIT	MIN	MAX	DEF
repeatWeeks5	1252	U_NO	0	5	0
startDD5	1253	U_NO	1	31	0
startMM5	1254	U_NO	1	12	0
endDD5	1255	U_NO	1	31	0
endMM5	1256	U_NO	1	12	0
Tariff6StartHH	1257	U_HR	0	23	0
Tariff6StartMM	1258	U_MN	0	59	0
Tariff6EndHH	1259	U_HR	0	23	0
Tariff6EndMM	1260	U_MN	0	59	0
repeatDays6	1261	U_NO	0	8	0
repeatWeeks6	1262	U_NO	0	5	0
TARIFF MANAGEMENT (2)	IDX	UNIT	MIN	MAX	DEF
startDD6	1300	U_NO	1	31	0
startMM6	1301	U_NO	1	12	0
endDD6	1302	U_NO	1	31	0
endMM6	1303	U_NO	1	12	0
Tariff7StartHH	1304	U_HR	0	23	0
Tariff7StartMM	1305	U_MN	0	59	0
Tariff7EndHH	1306	U_HR	0	23	0
Tariff7EndMM	1307	U_MN	0	59	0
repeatDays7	1308	U_NO	0	8	0
repeatWeeks7	1309	U_NO	0	5	0
startDD7	1310	U_NO	1	31	0
startMM7	1311	U_NO	1	12	0
endDD7	1312	U_NO	1	31	0
endMM7	1313	U_NO	1	12	0
Tariff8StartHH	1314	U_HR	0	23	0
Tariff8StartMM	1315	U_MN	0	59	0
Tariff8EndHH	1316	U_HR	0	23	0
Tariff8EndMM	1317	U_MN	0	59	0
repeatDays8	1318	U_NO	0	8	0
repeatWeeks8	1319	U_NO	0	5	0
startDD8	1320	U_NO	1	31	0
startMM8	1321	U_NO	1	12	0
endDD8	1322	U_NO	1	31	0
endMM8	1323	U_NO	1	12	0
Tariff9StartHH	1324	U_HR	0	23	0
Tariff9StartMM	1325	U_MN	0	59	0
Tariff9EndHH	1326	U_HR	0	23	0
Tariff9EndMM	1327	U_MN	0	59	0
repeatDays9	1328	U_NO	0	8	0
repeatWeeks9	1329	U_NO	0	5	0
startDD9	1330	U_NO	1	31	0
startMM9	1331	U_NO	1	12	0
endDD9	1332	U_NO	1	31	0
endMM9	1333	U_NO	1	12	0
Tariff10StartHH	1334	U_HR	0	23	0
Tariff10StartMM	1335	U_MN	0	59	0
Tariff10EndHH	1336	U_HR	0	23	0

TARIFF MANAGEMENT (2)	IDX	UNIT	MIN	MAX	DEF
Tariff10EndMM	1337	U_MN	0	59	0
repeatDays10	1338	U_NO	0	8	0
repeatWeeks10	1339	U_NO	0	5	0
startDD10	1340	U_NO	1	31	0
startMM10	1341	U_NO	1	12	0
endDD10	1342	U_NO	1	31	0
endMM10	1343	U_NO	1	12	0
BURST DETECTION	IDX	UNIT	MIN	MAX	DEF
enabled	1400	U_NO	0	1	0
RMDelay	1401	U_SE	0	99999	5
SettlePeriod	1402	U_SE	0	99999	10
OutflowMethod	1403	U_NO	0	1	0
STORM CONTROL	IDX	UNIT	MIN	MAX	DEF
enabled	1500	U_NO	0	1	0
DisableTime	1501	U_MN	0	99999	0
OVERSPILL DETECTION	IDX	UNIT	MIN	MAX	DEF
TTSpillenabled	1600	U_NO	0	1	0
OVFPersistCount	1601	U_NO	0	99999	10
alarmLvl	1602	U_MU	0	99999	99999
timeLimit	1603	U_SE	0	99999	99999
minPumpHead	1604	U_MU	0	99999	0
ovfLvl	1605	U_MU	0	99999	99999
resetLvl	1606	U_MU	0	99999	0
TTSpillCtenabled	1607	U_NO	0	1	0
dischargeLvl	1608	U_MU	0	99999	99999
SpillPeriod1	1609	U_HR	0	999	12
nextSpillPeriod	1610	U_HR	0	999	24
SpillTime	1611	U_MN	0	99999	0
SpillCount	1612	U_NO	0	99999	0
PUMPS EFFICIENCY	IDX	UNIT	MIN	MAX	DEF
enabled	1700	U_NO	0	1	0
DemotePump	1701	U_NO	0	1	0
persistCount	1702	U_NO	0	99999	6
Inflow Delay	1703	U_SE	0	99999	45
rateSampling	1704	U_SE	0	99999	1
PUMPED VOLUME	IDX	UNIT	MIN	MAX	DEF
outflowSRC	1800	U_NO	0	3	0
settleTime	1801	U_SE	0	99999	60
outflowLimit	1802	U_PC	0	100	10
selMeasIndex	1803	U_NO	0	31	0
VolumeIndex	1804	U_NO	0	5	0
TotaliserUnit	1805	U_NO	0	8	2
multiplier	1806	U_NO	0	12	3
decimals	1807	U_NO	0	3	2
dlyLogTimeHH	1808	U_HR	0	23	0
dlyLogTimeMM	1809	H_MN	0	59	0
dailyTots	1810	U_NO	0	999999	0
SystemTots	1811	U_NO	0	999999	0
ResettableTots	1812	U_NO	0	999999	0
t1	1813	U_NO	0	999999	0

PUMPED VOLUME	IDX	UNIT	MIN	MAX	DEF
tot1	1814	U_NO	0	999999	0
t2	1815	U_NO	0	999999	0
tot2	1816	U_NO	0	999999	0
t3	1817	U_NO	0	999999	0
tot3	1818	U_NO	0	999999	0
t4	1819	U_NO	0	999999	0
tot4	1820	U_NO	0	999999	0
t5	1821	U_NO	0	999999	0
tot5	1822	U_NO	0	999999	0
t6	1823	U_NO	0	999999	0
tot6	1824	U_NO	0	999999	0
t7	1825	U_NO	0	999999	0
tot7	1826	U_NO	0	999999	0
t8	1827	U_NO	0	999999	0
t9	1829	U_NO	0	999999	0
tot9	1830	U_NO	0	999999	0
t10	1831	U_NO	0	999999	0
tot10	1832	U_NO	0	999999	0
PUMPED VOLUME	IDX	UNIT	MIN	MAX	DEF
enabled	1900	U_NO	0	1	1
PowerDelay	1901	U_SE	0	99999	10
StartDelay	1902	U_SE	0	99999	10
StopDelay	1903	U_SE	0	99999	0
PUMP RUNTIME	IDX	UNIT	MIN	MAX	DEF
enabled	2000	U_NO	0	1	0
MaxRunTime	2001	U_MN	0	99999	99999
MaxPumpsRun	2002	U_NO	0	99	99
MaxPumpStarts	2003	U_NO	0	99	99
Interval	2004	U_MN	0	99999	99999
AUTO RESET	IDX	UNIT	MIN	MAX	DEF
enabled	2100	U_NO	0	1	0
Consec.Trip	2101	U_SE	0	99999	3
24HourTrip	2102	U_NO	0	99999	10
ResetInterval	2103	U_MN	0	99999	10
ResetPulse	2104	U_SE	0	99999	3
PUMP OVERRIDE	IDX	UNIT	MIN	MAX	DEF
enabled	2200	U_NO	0	1	0
OverrideDelay	2201	U_SE	0	99999	5
MinLevel	2202	U_MU	0	99999	0

DATE & TIME	IDX	UNIT	MIN	MAX	DEF
DSTenable	2300	U_NO	0	1	1
diffHH	2301	U_HR	0	23	1
diffMM	2302	U_MN	0	59	0
stDay	2303	U_NO	0	6	6
stWeek	2304	U_NO	0	4	4
stMonth	2305	U_NO	0	11	2
stHH	2306	U_HR	0	23	2
stMM	2307	U_MN	0	59	0
eDay	2308	U_NO	0	6	6
eWeek	2309	U_NO	0	4	4
eMonth	2310	U_NO	0	11	9
eHH	2311	U_HR	0	23	1
eMM	2312	U_MN	0	59	0
REMOTE COMMANDS	IDX	UNIT	MIN	MAX	DEF
Remote log on/off	2400	U_NO	0	65535	0
Reset event logs	2401	U_NO	0	1	0
Reset trending logs	2402	U_NO	0	1	0
Reset performance logs	2403	U_NO	0	1	0
Reset trace logs	2404	U_NO	0	1	0
Restart web server	2405	U_NO	0	1	0
Restart media server	2406	U_NO	0	1	0
Restart RTU	2407	U_NO	0	1	0
Firmware soft restart	2408	U_NO	0	1	0
Firmware hard restart	2409	U_NO	0	1	0
3G Router ping reboot	2410	U_NO	0	1	0
Save profile	2411	U_NO	0	1	0
Restart task manager	2412	U_NO	0	1	0
Read connection file	2413	U_NO	0	1	0
Apply new config	2414	U_NO	0	1	0
Activate maintenance	2415	U_NO	0	1	0
Select active profile	2416	U_NO	0	100	-1
Activate new profile	2417	U_NO	0	1	0
MAINTENANCE MODE	IDX	UNIT	MIN	MAX	DEF
Enable	2500	U_NO	0	1	1
Time Out	2501	U_NO	0	999	160
Time Out Alarm	2502	U_NO	0	1	1
Disable Control	2503	U_NO	0	1	1

MICROFLOW	IDX	UNIT	MIN	MAX	DEF	IDX1	IDX2	IDX32
Gain	11000	U_NO	1	16	10	11010	11020	11310
Damping	11001	U_NO	10	40	24	11011	11021	11311
DampingPersist	11002	U_NO	1	1000	12	11012	11022	11312
StepRespMode	11003	U_NO	0	1	1	11013	11023	11313
StepPersist	11004	U_NO	1	1000	12	11014	11024	11314
Response	11005	U_NO	0	1	1	11015	11025	11315
MinVelocity	11006	U_VEL	0	99999	0	11016	11026	11316
MaxVelocity	11007	U_VEL	0	99999	6000	11017	11027	11317
termination	11008	U_NO	0	1	0	11018	11028	11318
DIGITAL NPUTS	IDX	UNIT	MIN	MAX	DEF	IDX1	IDX2	IDX32
InputType	12000	U_NO	0	1	0	12010	12020	12310
Assignment	12001	U_NO	0	3	0	12011	12021	12311
Function	12002	U_NO				12012	12022	12312
MEASUREMENT POINTS	IDX	UNIT	MIN	MAX	DEF	IDX1	IDX2	IDX32
MeasMode	13000	U_NO	0	11	0	13010	13020	13290
Operation	13001	U_NO	0	3	0	13011	13021	13291
POWER MONITOR	IDX	UNIT	MIN	MAX	DEF	IDX1	IDX2	IDX32
TurnRatio	14000	U_NO	0	99999	100	14010	14020	14310
termination	14001	U_NO	0	1	0	14011	14021	14311
IRTEnable	14002	U_NO	0	1	0	14012	14022	14312
IRTInterval	14003	U_HR	0	99999	168	14013	14023	14313
IRValue	14004	U_MO	0	99999	0	14014	14024	14314
PUMP GROUP & DUTY	IDX	UNIT	MIN	MAX	DEF	IDX1	IDX2	IDX32
Duty	15000	U_NO	0	8	0	15010	15020	15040
PbT	15001	U_NO	0	1	0	15011	15021	15041
ECO_PUMPING	15002	U_NO	0	1	0	15012	15022	15042
VOLUMETRIC APPLICATIONS	IDX	UNIT	MIN	MAX	DEF	IDX1	IDX2	IDX32
AllocMeasIndex	16000	U_NO	0	31	0	16010	16020	16040
VesShape	16001	U_NO	0	13	0	16011	16021	16041
VUnits	16002	U_NO	0	8	2	16012	16022	16042
CorrFactor	16003	U_NO	0	999	1	16013	16023	16043
D1	16004	U_MU	0	99999	0	16014	16024	16044
D2	16005	U_MU	0	99999	0	16015	16025	16045
D3	16006	U_MU	0	99999	0	16016	16026	16046
CalculatedVol	16007	U_VU	0	99999	0	16017	16027	16047
UserVolume	16008	U_VU	0	99999	0	16018	16028	16048
D1	16004	U_MU	0	99999	0	16014	16024	16044
MA INPUT	IDX	UNIT	MIN	MAX	DEF	IDX1	IDX2	IDX32
mAIN_SensorType	20000	U_NO	0	4	0	20020	20040	20140
mAVal1	20001	U_MA	0	30	0	20021	20041	20141
mAVal2	20002	U_MA	0	30	0	20022	20042	20142
mAVal3	20003	U_MA	0	30	0	20023	20043	20143
mAVal4	20004	U_MA	0	30	0	20024	20044	20144

MA INPUT	IDX	UNIT	MIN	MAX	DEF	IDX1	IDX2	IDX32
mAVal5	20005	U_MA	0	30	0	20025	20045	20145
mAVal6	20006	U_MA	0	30	0	20026	20046	20146
inputVal1	20007	U_MU	0	99999	0	20027	20047	20147
inputVal2	20008	U_MU	0	99999	0	20028	20048	20148
inputVal3	20009	U_MU	0	99999	0	20029	20049	20149
inputVal4	20010	U_MU	0	99999	0	20030	20050	20150
inputVal5	20011	U_MU	0	99999	0	20031	20051	20151
inputVal6	20012	U_MU	0	99999	0	20032	20052	20152
LowTrim	20013	U_MA	-30	30	0	20033	20053	20153
HighTrim	20014	U_MA	-30	30	0	20034	20054	20154
ExtempType	20015	U_NO	0	1	0	20035	20055	20155
ExTempScale	20016	U_NO	0	99999	0	20036	20056	20156
ExTempOffset	20017	U_NO	99999	99999	0	20037	20057	20157
ALARM RELAY	IDX	UNIT	MIN	MAX	DEF	IDX1	IDX2	IDX32
AllocMeasPoint	21000	U_NO	0	31	0	21020	21040	21620
Setpoint1	21001	U_NO	0	99999	0	21021	21041	21621
Setpoint2	21002	U_NO	0	99999	0	21022	21042	21622
Setpoint3	21003	U_NO	0	99999	0	21023	21043	21623
Setpoint4	21004	U_NO	0	99999	0	21024	21044	21624
Closure	21005	U_NO	0	99999	0	21025	21045	21625
FailSafe	21006	U_NO	0	3	0	21026	21046	21626
eventSMS	21007	U_NO	0	1	0	21027	21047	21627
eventSound	21008	U_NO	0	1	0	21028	21048	21628
Remote forced setting	21009	U_NO	0	99999	0	21029	21049	21629
MA OUTPUT	IDX	UNIT	MIN	MAX	DEF	IDX1	IDX2	IDX32
range	22000	U_NO	0	3	1	22020	22040	22140
AllocMeasPoint	22001	U_NO	0	31	0	22021	22041	22141
LowLevel	22002	U_MU	0	99999	0	22022	22042	22142
HighLevel	22003	U_MU	0	99999	0	22023	22043	22143
LowLimit	22004	U_MA	0	30	4	22024	22044	22144
HighLimit	22005	U_MA	0	30	20	22025	22045	22145
LowTrim	22006	U_MA	-30	30	0	22026	22046	22146
HighTrim	22007	U_MA	-30	30	0	22027	22047	22147
FailMode	22008	U_NO	0	4	1	22028	22048	22148
Source	22009	U_NO	0	5	0	22029	22049	22149
Override Mode	22010	U_NO	0	3	0	22030	22050	22150
Override Value	22011	U_NO	0	25	0	22031	22051	22151
CONTROL RELAY	IDX	UNIT	MIN	MAX	DEF	IDX1	IDX2	IDX32
AllocMeasPoint	23000	U_NO	0	31	0	23020	23040	23620
Setpoint1	23001	U_NO	0	99999	0	23021	23041	23621
Setpoint2	23002	U_NO	0	99999	0	23022	23042	23622
Setpoint3	23003	U_NO	0	99999	0	23023	23043	23623
Setpoint4	23004	U_NO	0	99999	0	23024	23044	23624
Closure	23005	U_NO	0	99999	0	23025	23045	23625
FailSafe	23006	U_NO	0	3	0	23026	23046	23626
eventSMS	23007	U_NO	0	1	0	23027	23047	23627
Remote forced setting	23008	U_NO	0	99999	0	23028	23048	23628

CONTROL RELAY	IDX	UNIT	MIN	MAX	DEF	IDX1	IDX2	IDX32
AllocMeasPoint	23000	U_NO	0	31	0	23020	23040	23620
Setpoint1	23001	U_NO	0	99999	0	23021	23041	23621
Setpoint2	23002	U_NO	0	99999	0	23022	23042	23622
Setpoint3	23003	U_NO	0	99999	0	23023	23043	23623
Setpoint4	23004	U_NO	0	99999	0	23024	23044	23624
Closure	23005	U_NO	0	99999	0	23025	23045	23625
FailSafe	23006	U_NO	0	3	0	23026	23046	23626
eventSMS	23007	U_NO	0	1	0	23027	23047	23627
Remote forced setting	23008	U_NO	0	99999	0	23028	23048	23628
LOGICAL RELAY	IDX	UNIT	MIN	MAX	DEF	IDX1	IDX2	IDX32
sysRelayClosure	24000	U_NO	0	99999	0	24020	24040	24620
startDelay	24001	U_SE	0	99999	0	24021	24041	24621
minOnTime	24002	U_SE	0	99999	0	24022	24042	24622
failsafe	24003	U_NO	0	3	0	24023	24043	24623
eventSMS	24004	U_NO	0	1	0	24024	24044	24624
maxonTime	24005	U_SE	0	99999	0	24025	24045	24625
RepeatPulse	24006	U_NO	0	1	0	24026	24046	24626
MISCELLANEOUS RELAY	IDX	UNIT	MIN	MAX	DEF	IDX1	IDX2	IDX32
AllocMeasPoint	25000	U_NO	0	31	0	25020	25040	25620
Setpoint1	25001	U_NO	0	99999	0	25021	25041	25621
Setpoint2	25002	U_NO	0	99999	0	25022	25042	25622
Setpoint3	25003	U_NO	0	99999	0	25023	25043	25623
Setpoint4	25004	U_NO	0	99999	0	25024	25044	25624
Closure	25005	U_NO	0	99999	0	25025	25045	25625
FailSafe	25006	U_NO	0	3	0	25026	25046	25626
eventSMS	25007	U_NO	0	1	0	25027	25047	25627
Remoteforcedsetting	25008	U_NO	0	1	0	25028	25048	25628
PUMP RELAY	IDX	UNIT	MIN	MAX	DEF	IDX1	IDX2	IDX32
AllocMeasPoint	26000	U_NO	0	31	0	26020	26040	26620
Setpoint1	26001	U_NO	0	99999	0	26021	26041	26621
Setpoint2	26002	U_NO	0	99999	0	26022	26042	26622
Setpoint3	26003	U_NO	0	99999	0	26023	26043	26623
Setpoint4	26004	U_NO	0	99999	0	26024	26044	26624
Closure	26005	U_NO	0	99999	0	26025	26045	26625
Failsafe	26006	U_NO	0	3	0	26026	26046	26626
MaxRate	26007	U_MUS	99999	99999	0	26027	26047	26627
standby	26008	U_NO	0	1	0	26028	26048	26628
eventSMS	26009	U_NO	0	1	0	26029	26049	26629
remoteforcedsetting	26010	U_NO	0	99999	0	26030	26050	26630

FLOWPULSE	IDX	UNIT	MIN	MAX	DEF	IDX1	IDX2	IDX32
Sensitivity	27000	U_NO	800	4000	1600	27020	27040	27620
PipeIntDia	27001	U_MU	0	9000	15	27021	27041	27621
Damping	27002	U_NO	10	40	24	27022	27042	27622
CalibFactor	27003	U_NO	0	999	100	27023	27043	27623
StepResp	27004	U_NO	0	1	1	27024	27044	27624
StepRespThresh	27005	U_NO	40	400	60	27025	27045	27625
StepResLimit	27006	U_NO	40	400	120	27026	27046	27626
Density	27007	U_NO	0	4	2	27027	27047	27627
MinCutoff	27008	U_NO	256	4000	740	27028	27048	27628
NoiseThresh	27009	U_NO	500	3000	1000	27029	27049	27629
TrackMethod	27010	U_NO	0	5	0	27030	27050	27630
Termination	27011	U_NO	0	1	0	27031	27051	27631
GradThreshold	27012	U_NO	50	1000	140	27032	27052	27632
SigMode	27013	U_NO	0	10	0	27033	27053	27633
GENERAL TOTALISERS	IDX	UNIT	MIN	MAX	DEF	IDX1	IDX2	IDX32
Hourly Totaliser	28000	U_NO	0	8	2	28020	28040	28060	28380
Daily Totaliser	28001	U_NO	0	2	0	28021	28041	28061	28381
Weekly Totaliser	28002	U_MU	0	99999	6000	28022	28042	28062	28382
Monthly Totaliser	28003	U_MU	0	99999	5700	28023	28043	28063	28383
Yearly Totaliser	28004	U_MU	0	99999	300	28024	28044	28064	28384
Resettable Totaliser	28005	U_PC	0	100	20	28025	28045	28065	28385
System Totaliser	28006	U_PC	0	100	20	28026	28046	28066	28386
dlyHH	28007	U_HR	0	23	0	28027	28047	28067	28387
dlyMM	28008	U_MN	0	59	0	28028	28048	28068	28388
OCM APPLICATIONS	IDX	UNIT	MIN	MAX	DEF	IDX1	IDX2	IDX32
AllocMeasIndex	30000	U_NO	0	31	0	30050	30100	30150	30200
pmdType	30001	U_NO	0	6	0	30051	30101	30151	30201
PriPMD	30002	U_NO				30052	30102	30152	30202
Calculation	30003	U_NO	0	1	0	30053	30103	30153	30203
DimA	30004	U_MU	0	99999	0	30054	30104	30154	30204
DimB	30005	U_MU	0	99999	0	30055	30105	30155	30205
DimC	30006	U_MU	0	99999	0	30056	30106	30156	30206
RoughnessKs	30007	U_NO	0	99999	0	30057	30107	30157	30207
waterTemp	30008	U_TP	-999	999	15	30058	30108	30158	30208
MinHead	30009	U_MU	0	99999	0	30059	30109	30159	30209
MaxHead	30010	U_MU	0	99999	0	30060	30110	30160	30210
MaxFlow	30011	U_NO	0	99999	0	30061	30111	30161	30211
FlowDecimal	30012	U_NO	0	3	2	30062	30112	30162	30212
FlowCutOFF	30013	U_PC	0	100	5	30063	30113	30163	30213
AVGTime	30014	U_NO	0	999	5	30064	30114	30164	30214
VolumeUnits	30015	U_NO	0	5	1	30065	30115	30165	30215
TimeUnits	30016	U_NO	0	3	0	30066	30116	30166	30216
kfactor	30017	U_NO	0	99999	0	30067	30117	30167	30217
exponent	30018	U_NO	-99	99	0	30068	30118	30168	30218
totUnit	30019	U_NO	0	5	0	30069	30119	30169	30219
multiplier	30020	U_NO	0	12	3	30070	30120	30170	30220
decimals	30021	U_NO	0	3	2	30071	30121	30171	30221
dlyHH	30022	U_HR	0	23	0	30072	30122	30172	30222
dlyMM	30023	U_MN	0	59	0	30073	30123	30173	30223
dlyTot	30024	U_NO	0	9999999	0	30074	30124	30174	30224

OCM APPLICATIONS	IDX	UNIT	MIN	MAX	DEF	IDX1	IDX2	IDX32
sysTot	30025	U_NO	0	9999999	0	30075	30125	30175	30225
rstTot	30026	U_NO	0	9999999	0	30076	30126	30176	30226
velMeasIndex	30027	U_NO	0	31	0	30077	30127	30177	30227
totEnable	30028	U_NO	0	1	0	30078	30128	30178	30228
LOGIC OUTPUTS	IDX	UNIT	MIN	MAX	DEF	IDX1	IDX2	IDX32
paramIndex1	31000	U_NO	0	3949	0	31050	31100	31150	31950
ONSetpoint1	31001	U_NO	99999	99999	0	31051	31101	31151	31951
OFFSetpoint1	31002	U_NO	99999	99999	0	31052	31102	31152	31952
delay1	31003	U_SE	0	99999	0	31053	31103	31153	31953
currLogic1	31004	U_NO	0	4	0	31054	31104	31154	31954
paramIndex2	31005	U_NO	0	3949	0	31055	31105	31155	31955
ONSetpoint2	31006	U_NO	99999	99999	0	31056	31106	31156	31956
OFFSetpoint2	31007	U_NO	99999	99999	0	31057	31107	31157	31957
delay2	31008	U_SE	0	99999	0	31058	31108	31158	31958
currLogic2	31009	U_NO	0	4	0	31059	31109	31159	31959
paramIndex3	31010	U_NO	0	3949	0	31060	31110	31160	31960
ONSetpoint3	31011	U_NO	99999	99999	0	31061	31111	31161	31961
OFFSetpoint3	31012	U_NO	99999	99999	0	31062	31112	31162	31962
delay3	31013	U_SE	0	99999	0	31063	31113	31163	31963
currLogic3	31014	U_NO	0	4	0	31064	31114	31164	31964
paramIndex4	31015	U_NO	0	3949	0	31065	31115	31165	31965
ONSetpoint4	31016	U_NO	99999	99999	0	31066	31116	31166	31966
OFFSetpoint4	31017	U_NO	99999	99999	0	31067	31117	31167	31967
delay4	31018	U_SE	0	99999	0	31068	31118	31168	31968
currLogic4	31019	U_NO	0	4	0	31069	31119	31169	31969
paramIndex5	31020	U_NO	0	3949	0	31070	31120	31170	31970
ONSetpoint5	31021	U_NO	99999	99999	0	31071	31121	31171	31971
OFFSetpoint5	31022	U_NO	99999	99999	0	31072	31122	31172	31972
delay5	31023	U_SE	0	99999	0	31073	31123	31173	31973
currLogic5	31024	U_NO	0	4	0	31074	31124	31174	31974
sendSMS	31025	U_NO	0	1	0	31075	31125	31175	31975
TRANSDUCER									
DISTANCE	IDX	UNIT	MIN	MAX	DEF	IDX1	IDX2	IDX32
TransducerType	40000	U_NO	0	8	2	40100	40200	40300	40700
Material	40001	U_NO	0	2	0	40101	40201	40301	40701
Empty	40002	U_MU	0	99999	6000	40102	40202	40302	40702
Span	40003	U_MU	0	99999	5700	40103	40203	40303	40703
NearBlank	40004	U_MU	0	99999	300	40104	40204	40304	40704
FarBlank	40005	U_PC	0	100	20	40105	40205	40305	40705
COMPENSATION	IDX	UNIT	MIN	MAX	DEF	IDX1	IDX2	IDX32
MeasurementOffset	40006	U_MU	99999	99999	0	40106	40206	40306	40706
TempSource	40007	U_NO	0	4	0	40107	40207	40307	40707
TempAlloc	40008	U_NO	0	31	0	40108	40208	40308	40708
TempOffset	40009	U_TP	99999	99999	0	40109	40209	40309	40709
FixedTemp	40010	U_TP	99999	99999	0	40110	40210	40310	40710
NumTempAverage	40011	U_NO	0	50	3	40111	40211	40311	40711
SoundVelocity	40012	U_VEL	0	999999	342720	40112	40212	40312	40712

STABILITY	IDX	UNIT	MIN	MAX	DEF	IDX1	IDX2	IDX32
RateUpdate	40013	U_NO	0	1	0	40113	40213	40313	40713
RateTime	40014	U_SE	0	3600	60	40114	40214	40314	40714
RateDistance	40015	U_MU	0	99999	50	40115	40215	40315	40715
RateCutOff	40016	U_MUS	0	99999	0	40116	40216	40316	40716
RateSampling	40017	U_SE	0	3600	1	40117	40217	40317	40717
RateArrayCount	40018	U_NO	0	12	4	40118	40218	40318	40718
ProcessFilter	40019	U_NO	0	2	2	40119	40219	40319	40719
PeakPercentage	40020	U_PC	0	100	50	40120	40220	40320	40720
FillDamping	40021	U_MUS	0	99999	10000	40121	40221	40321	40721
EmptyDamping	40022	U_MUS	0	99999	10000	40122	40222	40322	40722
echo process	idx	unit	min	max	def	idx1	idx2	idx32
Sensitivity	40023	U_DB	0	99	5	40123	40223	40323	40723
sideTolerance	40024	U_MU	0	99999	50	40124	40224	40324	40724
GateMode	40025	U_NO	0	1	0	40125	40225	40325	40725
FixedDistance	40026	U_MU	0	99999	200	40126	40226	40326	40726
SERVICE MENU									
ECHO	IDX	UNIT	MIN	MAX	DEF	IDX1	IDX2	IDX32
Breakpoint	40027	U_MU	0	99999	5000	40127	40227	40327	40727
Slope	40028	U_NO	0	99999	3	40128	40228	40328	40728
Numaverage	40029	U_NO	0	50	3	40129	40229	40329	40729
Scalefirst	40030	U_PC	0	100	40	40130	40230	40330	40730
OutsideCount	40031	U_NO	0	5000	10	40131	40231	40331	40731
DATEM FLAG	IDX	UNIT	MIN	MAX	DEF	IDX1	IDX2	IDX32
Echo Source	40032	U_NO	0	99999	5000	40132	40232	40332	40732
Datem Update	40033	U_NO	0	99999	3	40133	40233	40333	40733
DATEM CUSTOM	IDX	UNIT	MIN	MAX	DEF	IDX1	IDX2	IDX32
Start Point	40034	U_MU	0	99999	250	40134	40234	40334	40734
Mid-Point	40035	U_MV	0	999	700	40135	40235	40335	40735
End Point	40036	U_NO	0	99999	800	40136	40236	40336	40736
Min Datem	40037	U_NO	0	1	1	40137	40237	40337	40737
ULTRASOUND	IDX	UNIT	MIN	MAX	DEF	IDX1	IDX2	IDX32
RingDownLoss	40038	U_DB	0	99	7	40138	40238	40338	40738
NearLoss	40039	U_DB	0	99	15	40139	40239	40339	40739
MidLoss	40040	U_DB	0	99	15	40140	40240	40340	40740
LossChange	40041	U_MU	0	99999	2000	40141	40241	40341	40741
FarLoss	40042	U_DB	0	99	5	40142	40242	40342	40742
UNCLASSIFIED	IDX	UNIT	MIN	MAX	DEF	IDX1	IDX2	IDX32
SetDatem	40043	U_NO	0	3	0	40143	40243	40343	40743
SelectPeak	40044	U_MU	0	99999	0	40144	40244	40344	40744
PingDelay	40045	U_NO	0	99999	0	40145	40245	40345	40745

APPENDIX C – ULTIMATE PROFIBUS MODULE DEFINITIONS

The following registers are Profibus module definitions and can be viewed and written to in order to change a value. To write to an address you will need to remotely log on using index XX and enter the passcode for your controller. The following table shows the unit symbols and their corresponding descriptions

UNIT/RANGE	DEFINITION
U_NO	None
U_MN	Minutes
U_HR	Hours
U_KW	Kilowatts
U_VOL	Voltage
U_CURR	Current
U_PC	Percentage
U_VEL	m/sec
U_FLO	Flow Units
U_MU	System unit
U_DB	Decibel
U_TP	Degree C
U_MA	mA
U_VU	Volume unit

INDEX	DESCRIPTION	UNIT
Module 1: Measured Point 1		
0	Point 1 Level	U_MU
1	Point 1 Distance	U_MU
2	Echo 1 Confidence	U_DB
3	Echo 1 Strength	U_DB
4	Echo 1 HALL	U_DB
5	Average Noise 1	U_DB
6	Peak Noise 1	U_DB
7	Point 1 Temperature	U_TP
Module 2: Measured Point 2		
0	Point 2 Level	U_MU
1	Point 2 Distance	U_MU
2	Echo 2 Confidence	U_DB
3	Echo 2 Strength	U_DB
4	Echo 2 HALL	U_DB
5	Average Noise 2	U_DB
6	Peak Noise 2	U_DB
7	Point 2 Temperature	U_TP
Module 3: mA I/O		
0	"number of controls"	U_NO
1	"number of miscellaneous"	U_NO
2	"number of logics"	U_NO

INDEX	DESCRIPTION	UNIT
Module 4: Statuses		
0	"Relay statuses"	
1	"Digital Inputs"	U_NO
2	"Ultrasonic level status"	U_NO
Module 5: Station Overview		
0	"sump level"	U_MU
1	"transducer 1 status"	U_NO
2	"transducer 1 confidence"	U_PC
3	"transducer 2 status"	U_NO
4	"transducer 2 confidence"	U_PC
5	"mA input 1 value"	U_MA
6	"mA input 1 status"	U_NO
7	"mA input 2 value"	U_MA
8	"mA input 2 status"	U_NO
9	"relay status (1-8)"	U_NO
10	"digital input status (1-8)"	U_NO
Module 6: Station Info 1		
0	"total num of pumps"	U_NO
1	"num of fault pumps"	U_NO
2	"num of demoted pumps"	U_NO
3	"pump fails duration"	U_NO
4	"num of mains faults"	U_NO
5	"num of DC faults"	U_NO
6	"num of xdr faults"	U_NO
7	"analogue input fails"	U_NO
Module 7: Station Info 2		
0	"backup operation is active"	U_NO
1	"hi level alarm is operating"	U_NO
2	"hi hi level alarm is operating"	U_NO
3	"lo level alarm is operating"	U_NO
4	"lo lo level alarm is operating"	U_NO
5	"storm disable pump is operating"	U_NO
6	"overspill is operating"	U_NO
7	"tariff management is operating"	U_NO
8	"pump blocked is active"	U_NO
9	"pump burst is active"	U_NO
Module 8: Station Info 3		
0	"num of valid log ons"	U_NO
1	"num of invalid log ons"	U_NO
2	"operating times in hours"	U_HR
Module 9: Station Info 4		
0	"total num of pump starts"	U_NO
1	"total pump run time"	
Module 10: Station Info 5		
0	"num of rma blocks detected"	U_NO
1	"num of rma burst detected"	U_NO
2	"num of RetroFlo pump reversals"	U_NO
3	"num of storm disable"	U_NO
4	"num of storm detected"	U_NO
Module 11: Station Info 6		
0	"total pumped volume"	U_VU
1	"total kWh used"	U-KW

INDEX	DESCRIPTION	UNIT
Module 12: Station Info 7		
0	"system totaliser"	U_VU
1	"resettable totaliser"	U_VU
2	"daily totaliser"	U_VU
Module 5: Station Info 8		
0	"time to spill"	U_MN
1	"overflow duration"	U_MN
2	"num of spill counts"	U_NO
Module 14: Station Info 9		
0	"num of fill cycles this week"	U_NO
1	"average fill time this week"	U_MN
2	"num of empty cycles this week"	U_NO
3	"average empty time this week"	U_MN
Module 15: Station Info 10		
0	"num of alarm starts"	U_NO
1	"num of alarm starts this week"	U_NO
2	"num of control starts"	U_NO
3	"num of control starts this week"	U_NO
4	"num of misc starts"	U_NO
5	"num of misc starts this week"	U_NO
6	"num of pump starts this week"	U_NO
7	"num of pump starts last week"	U_NO
8	"total pump run time this week"	U_MN
9	"total pump run time last week"	U_MN
10	"num of fill cycles last week"	U_NO
11	"average fill time last week"	U_MN
12	"num of empty cycles last week"	U_NO
13	"average empty time last week"	U_MN
14	"num of alarm starts last week"	U_NO
15	"num of control starts last week"	U_NO
16	"num of misc starts last week"	U_NO
17	"total pumped volume last week"	U_VU
18	"total kWh last week"	U_KW
19	"station API"	U_PC
Module 16: Station Info 11		
0	"mains fault active"	U_NO
1	"dc fault active"	U_NO
2	"dc fault low active"	U_NO
Module 17: Station Info 12		
0	"pump is running on"	U_NO
1	"num of RetroFlo blocks detected"	U_NO
2	"next pump to start"	U_NO
3	"pump exercising"	U_NO
4	"maintenance mode activated"	U_NO
Module 18: Station Info 13		
0	"inflow rate"	U_FLO
1	"sum level"	U_MU
2	"sum level percent"	U_PC
3	"sum volume"	U_VU
4	"sum volume percent"	U_PC
Module 19: Transducer 1		
0	"xdr 1 status"	U_NO
1	"xdr 1 confidence"	U_MU
2	"xdr 1 temperature"	U_PC
3	"xdr 1 echo strength"	U_VU

4	"xdr 1 noise level"	U_DB
INDEX	DESCRIPTION	UNIT
Module 20: Transducer 2		
Module 21: Transducer 3		
Module 22: Transducer 4		
Module 23: Transducer 5		
Module 24: Transducer 6		
Module 25: Transducer 6		
Module 26: Transducer 8		
Module 27: mA Input 1		
0	"mA input 1 value"	U_MA
1	"mA input 1 status"	U_NO
2	"mA input rate"	U_NO
3	"mA input under range"	U_NO
4	"mA input over range"	U_NO
Module 28: mA Input 2		
Module 29: mA Input 3		
Module 30: mA Input 4		
Module 31: mA Input 5		
Module 32: mA Input 6		
Module 33: mA Input 7		
Module 34: mA Input 8		
Module 35: mA Output 1		
0	"mA Out 1 value"	U_MA
1	"mA Out 1 high level"	U_MU
2	"mA Out low level"	U_MU
Module 36: mA Output 2		
Module 37: mA Output 3		
Module 38: mA Output 4		
Module 39: mA Output 5		
Module 40: mA Output 6		
Module 41: mA Output 7		
Module 42: mA Output 8		
Module 43: Digital Inputs		
0	"Digital input 1 value"	U_NO
1	"Digital input 2 value"	U_NO
2	"Digital input 3 value"	U_NO
3	"Digital input 4 value"	U_NO
4	"Digital input 5 value"	U_NO
5	"Digital input 6 value"	U_NO
6	"Digital input 7 value"	U_NO
7	"Digital input 8 value"	U_NO
8	"Digital input 9 value"	U_NO
9	"Digital input 10 value"	U_NO
10	"Digital input 11 value"	U_NO
11	"Digital input 12 value"	U_NO
12	"Digital input 13 value"	U_NO
13	"Digital input 14 value"	U_NO
14	"Digital input 15 value"	U_NO
15	"Digital input 16 value"	U_NO
16	"Digital input 17 value"	U_NO
17	"Digital input 18 value"	U_NO
18	"Digital input 19 value"	U_NO
19	"Digital input 20 value"	U_NO
20	"Digital input 21 value"	U_NO
21	"Digital input 22 value"	U_NO

INDEX	DESCRIPTION	UNIT
22	"Digital input 23 value"	U_NO
23	"Digital input 24 value"	U_NO
24	"Digital input 25 value"	U_NO
25	"Digital input 26 value"	U_NO
26	"Digital input 27 value"	U_NO
27	"Digital input 28 value"	U_NO
28	"Digital input 29 value"	U_NO
29	"Digital input 30 value"	U_NO
30	"Digital input 31 value"	U_NO
31	"Digital input 32 value"	U_NO
32	"Digital input 33 value"	U_NO
33	"Digital input 34 value"	U_NO
34	"Digital input 35 value"	U_NO
35	"Digital input 36 value"	U_NO
36	"Digital input 37 value"	U_NO
37	"Digital input 38 value"	U_NO
38	"Digital input 39 value"	U_NO
39	"Digital input 40 value"	U_NO
Module 44: Pump 1		
0	"relay status"	U_NO
1	"manual on"	U_NO
2	"manual off"	U_NO
3	"pump tripped"	U_NO
4	"trip counter"	U_NO
5	"pump demoted"	U_NO
6	"failed time"	U_MN
7	"demoted count"	U_NO
8	"pump blocked is active"	U_NO
9	"blockage count"	U_NO
10	"auto reversing is active"	U_NO
11	"auto reversing count"	U_NO
12	"pump out of service count"	U_NO
13	"out of service"	U_NO
14	"num of starts"	U_NO
15	"num starts per interval"	U_NO
16	"num starts this week"	U_NO
17	"num run ons"	U_NO
18	"num exercises"	U_NO
19	"total run time"	U_MN
20	"total run time this week"	U_MN
21	"total kWh used"	U_KW
22	"calibrated kWh/m3"	U_NO
23	"efficiency"	U_PC
24	"total pumped volume"	U_VU
25	"pumped volume this week"	U_VU
26	"storm disable count"	U_NO
27	"out of service count"	U_NO
28	"pump throughput"	U_FLO
29	"pump rate"	U_FLO
30	"pump energy efficient"	U_NO
31	"phase A voltage"	U_VOLT
32	"phase B voltage"	U_VOLT
33	"phase C voltage"	U_VOLT
34	"phase A current"	U_CURR
35	"phase B current"	U_CURR

INDEX	DESCRIPTION	UNIT
36	"phase C current"	U_CURR
37	"power factor"	U_NO
38	"runtime with no inflow"	U_SEC
39	"max starts active"	U_NO
40	"IRT resistance"	U_NO
41	"apparent power"	U_KW
42	"real power"	U_KW
43	"pump setpoint 1"	U_NO
44	"pump setpoint 2"	U_NO
45	"pump setpoint 3"	U_NO
46	"pump setpoint 4"	U_NO
47	"pump duty"	U_NO
48	"pump auto control"	U_NO
49	"power factor ok"	U_NO
50	Not assigned	
51	Not assigned	
52	Not assigned	
53	"under current"	U_NO
54	"over current"	U_NO
55	"reversal counter"	U_NO
56	"num of RetroFlo clearance"	U_NO
57	"instantaneous kWh/m3"	U_NO
58	"pump PMI"	U_PC
59	"remote forced setting"	U_NO
Module 45: Pump 2		
Module 46: Pump 3		
Module 47: Pump 4		
Module 48: Pump 5		
Module 49: Pump 6		
Module 50: Pump 7		
Module 51: Pump 8		
Module 52: Alarm 1		
0	"relay status"	U_NO
1	"num relay closures"	U_NO
Module 53: Alarm 2		
Module 54: Alarm 3		
Module 55: Alarm 4		
Module 56: Alarm 5		
Module 57: Alarm 6		
Module 58: Alarm 7		
Module 59: Alarm 8		
Module 60: Control 1		
0	"relay status"	U_NO
1	"num relay closures"	U_NO
Module 61: Control 2		
Module 62: Control 3		
Module 63: Control 4		
Module 64: Control 5		
Module 65: Control 6		
Module 66: Control 7		
Module 67: Control 8		
Module 68: Measurement Point 1		
0	"out"	U_NO
1	"out percent"	U_NO
2	"rate"	U_NO

INDEX	DESCRIPTION	UNIT
	Module 69: Measurement Point 2	
	Module 70: Measurement Point 3	
	Module 71: Measurement Point 4	
	Module 72: Measurement Point 5	
	Module 73: Measurement Point 6	
	Module 74: Measurement Point 7	
	Module 75: Measurement Point 8	
	Module 76: Measurement Point 9	
	Module 77: Measurement Point 10	
	Module 78: Measurement Point 11	
	Module 79: Measurement Point 12	
	Module 80: Measurement Point 13	
	Module 81: Measurement Point 14	
	Module 82: Measurement Point 15	
	Module 83: Measurement Point 16	
	Module 84: Measurement Point 17	
	Module 85: Measurement Point 18	
	Module 86: Measurement Point 19	
	Module 87: Measurement Point 20	
	Module 88: Measurement Point 21	
	Module 89: Measurement Point 22	
	Module 90: Measurement Point 23	
	Module 91: Measurement Point 24	
	Module 92: Measurement Point 25	
	Module 93: Measurement Point 26	
	Module 94: Measurement Point 27	
	Module 95: Measurement Point 28	
	Module 96: Measurement Point 29	
	Module 97: Measurement Point 30	
	Module 98: Logic Point 1	
0	"relay status"	U_NO
1	"num relay closures"	U_NO
	Module 99: Logic Point 2	
	Module 100: Logic Point 2	
	Module 101: Logic Point 3	
	Module 102: Logic Point 4	
	Module 103: Logic Point 5	
	Module 104: Logic Point 6	
	Module 105: Logic Point 7	
	Module 106: Logic Point 8	
	Module 107: Logic Point 9	
	Module 108: Logic Point 10	
	Module 109: Logic Point 11	
	Module 110: Logic Point 12	
	Module 111: Logic Point 13	
	Module 112: Logic Point 14	
	Module 113: Logic Point 15	
	Module 114: Logic Point 16	
	Module 115: Logic Point 17	
	Module 116: Logic Point 18	
	Module 117: Logic Point 19	
	Module 118: Logic Point 20	

INDEX	DESCRIPTION	UNIT
	Module 119: Logic Point 21	
	Module 120: Logic Point 22	
	Module 121: Logic Point 23	
	Module 122: Logic Point 24	
	Module 123: Logic Point 25	
	Module 124: Logic Point 26	
	Module 125: Logic Point 27	
	Module 126: Logic Point 28	
	Module 127: Logic Point 29	
	Module 128: Logic Point 30	
	Module 129: Logic Point 31	
	Module 130: Logic Point 32	
	Module 131: Logical Point 1	
0	"out value"	U_NO
	Module 132: Logical Point 2	
	Module 133: Logical Point 2	
	Module 134: Logical Point 3	
	Module 135: Logical Point 4	
	Module 136: Logical Point 5	
	Module 137: Logical Point 6	
	Module 138: Logical Point 7	
	Module 139: Logical Point 8	
	Module 140: Logical Point 9	
	Module 141: Logical Point 10	
	Module 142: Logical Point 11	
	Module 143: Logical Point 12	
	Module 144: Logical Point 13	
	Module 145: Logical Point 14	
	Module 146: Logical Point 15	
	Module 147: Logical Point 16	
	Module 148: Logical Point 17	
	Module 149: Logical Point 18	
	Module 150: Logical Point 19	
	Module 151: Logical Point 20	
	Module 152: OCM 1	
0	"calculated flow"	U_NO
1	"calculated flow percent"	U_PC
2	"average flow"	U_NO
3	"head"	U_MU
4	"head percent"	U_PC
5	"daily tot"	U_NO
6	"resettable tot"	U_NO
7	"system tot"	U_NO
	Module 153: OCM 2	
	Module 154: OCM 3	
	Module 155: OCM 4	
	Module 156: OCM 5	
	Module 157: Volume 1	
0	"calculated volume"	U_NO
1	"calculated volume percent"	U_PC
	Module 158: Volume 2	
	Module 159: Volume 3	
	Module 160: Volume 4	

INDEX	DESCRIPTION	UNIT
Module 161: Volume 5		
Module 162: Volume 6		
Module 163: General Totaliser 1		
0	"Hourly Totaliser"	U_NO
1	"Daily Totaliser"	U_NO
2	"Weekly Totaliser"	U_NO
3	"Monthly Totaliser"	U_NO
4	"Yearly Totaliser"	U_NO
5	"Resettable Totaliser"	U_NO
6	"System Totaliser"	U_NO
Module 164: General Totaliser 2		
Module 165: General Totaliser 3		
Module 166: General Totaliser 4		
Module 168: General Totaliser 5		
Module 169: General Totaliser 6		
Module 170: General Totaliser 7		
Module 171: General Totaliser 8		
Module 172: General Totaliser 9		
Module 173: General Totaliser 10		
Module 178: mA Input 9		
0	"mA input 9 value"	U_MA
1	"mA input 9 status"	U_NO
2	"mA input 9 rate"	U_NO
3	"mA input 9 under range"	U_NO
4	"mA input 9 over range"	U_NO
Module 179: mA Input 10		
Module 180: mA Input 11		
Module 181: mA Input 12		
Module 182: mA Input 13		
Module 183: mA Input 14		
Module 184: mA Input 15		
Module 185: mA Input 16		
Module 186: mA Input 17		
Module 187: mA Input 18		
Module 188: mA Input 19		
Module 189: mA Input 20		
Module 190: mA Input 21		
Module 191: mA Input 22		
Module 192: mA Input 23		
Module 193: mA Input 24		
Module 194: mA Input 25		
Module 195: mA Input 26		
Module 196: Digital Inputs (41-62)		
0	"Digital input 41 value"	U_NO
1	"Digital input 42 value"	U_NO
2	"Digital input 43 value"	U_NO
3	"Digital input 44 value"	U_NO
4	"Digital input 45 value"	U_NO
5	"Digital input 46 value"	U_NO
6	"Digital input 47 value"	U_NO
7	"Digital input 48 value"	U_NO
8	"Digital input 49 value"	U_NO

INDEX	DESCRIPTION	UNIT
9	"Digital input 50 value"	U_NO
10	"Digital input 51 value"	U_NO
11	"Digital input 52 value"	U_NO
12	"Digital input 53 value"	U_NO
13	"Digital input 54 value"	U_NO
14	"Digital input 55 value"	U_NO
15	"Digital input 56 value"	U_NO
16	"Digital input 57 value"	U_NO
17	"Digital input 58 value"	U_NO
18	"Digital input 59 value"	U_NO
19	"Digital input 60 value"	U_NO
20	"Digital input 61 value"	U_NO
21	"Digital input 62 value"	U_NO
Module 197: Digital Inputs (63-84)		
0	"Digital input 63 value"	U_NO
1	"Digital input 64 value"	U_NO
2	"Digital input 65 value"	U_NO
3	"Digital input 66 value"	U_NO
4	"Digital input 67 value"	U_NO
5	"Digital input 68 value"	U_NO
6	"Digital input 69 value"	U_NO
7	"Digital input 70 value"	U_NO
8	"Digital input 71 value"	U_NO
9	"Digital input 72 value"	U_NO
10	"Digital input 73 value"	U_NO
11	"Digital input 74 value"	U_NO
12	"Digital input 75 value"	U_NO
13	"Digital input 76 value"	U_NO
14	"Digital input 77 value"	U_NO
15	"Digital input 78 value"	U_NO
16	"Digital input 79 value"	U_NO
17	"Digital input 80 value"	U_NO
18	"Digital input 81 value"	U_NO
19	"Digital input 82 value"	U_NO
20	"Digital input 83 value"	U_NO
21	"Digital input 84 value"	U_NO
Module 198: Digital Inputs (85-106)		
0	"Digital input 85 value"	U_NO
1	"Digital input 86 value"	U_NO
2	"Digital input 87 value"	U_NO
3	"Digital input 88 value"	U_NO
4	"Digital input 89 value"	U_NO
5	"Digital input 90 value"	U_NO
6	"Digital input 91 value"	U_NO
7	"Digital input 92 value"	U_NO
8	"Digital input 93 value"	U_NO
9	"Digital input 94 value"	U_NO
10	"Digital input 95 value"	U_NO
11	"Digital input 96 value"	U_NO
12	"Digital input 97 value"	U_NO
13	"Digital input 98 value"	U_NO
14	"Digital input 99 value"	U_NO
15	"Digital input 100 value"	U_NO
16	"Digital input 101 value"	U_NO
17	"Digital input 102 value"	U_NO
INDEX	DESCRIPTION	UNIT

18	"Digital input 50 value"	U_NO
19	"Digital input 51 value"	U_NO
20	"Digital input 52 value"	U_NO
21	"Digital input 53 value"	U_NO
Module 199: Digital Inputs (107-128)		
0	"Digital input 107 value"	U_NO
1	"Digital input 108 value"	U_NO
2	"Digital input 109 value"	U_NO
3	"Digital input 110 value"	U_NO
4	"Digital input 111 value"	U_NO
5	"Digital input 112 value"	U_NO
6	"Digital input 113 value"	U_NO
7	"Digital input 114 value"	U_NO
8	"Digital input 115 value"	U_NO
9	"Digital input 116 value"	U_NO
10	"Digital input 117 value"	U_NO
11	"Digital input 118 value"	U_NO
12	"Digital input 119 value"	U_NO
13	"Digital input 120 value"	U_NO
14	"Digital input 121 value"	U_NO
15	"Digital input 122 value"	U_NO
16	"Digital input 123 value"	U_NO
17	"Digital input 124 value"	U_NO
18	"Digital input 125 value"	U_NO
19	"Digital input 126 value"	U_NO
20	"Digital input 127 value"	U_NO
21	"Digital input 128 value"	U_NO
Module 200: Counter Inputs		
0	"Counter input 1"	U_NO
1	"Counter input 2"	U_NO
2	"Counter input 3"	U_NO
3	"Counter input 4"	U_NO
4	"Counter input 5"	U_NO
5	"Counter input 6"	U_NO
6	"Counter input 7"	U_NO
7	"Counter input 8"	U_NO
8	"Counter input 9"	U_NO
Module 201: Frequency Inputs		
0	"Frequency input 1"	U_NO
1	"Frequency input 2"	U_NO
2	"Frequency input 3"	U_NO
3	"Frequency input 4"	U_NO
4	"Frequency input 5"	U_NO
5	"Frequency input 6"	U_NO
6	"Frequency input 7"	U_NO
7	"Frequency input 8"	U_NO
8	"Frequency input 9"	U_NO

APPENDIX D - DISPOSAL

Instructions on returning products to Pulsar

If there is any issues or queries regarding the controller or any of the Pulsar devices used, please contact your local Pulsar Measurement partner for assistance.

Instructions for disposal

Incorrect disposal can cause adverse effects to the environment.

Dispose of the device components and packaging material in accordance with regional environmental regulations including regulations for electrical \ electronic products.

Transducers

Remove power, disconnect the Transducer, cut off the electrical cable and dispose of cable and Transducer in accordance with regional environmental regulations for electrical \ electronic products.

Controllers

Remove power, disconnect the Controller, and remove battery (if fitted). Dispose of Controller in accordance with regional environmental regulations for electrical \ electronic products.

Dispose of batteries in accordance with regional environmental regulations for batteries.



■ EU WEEE Directive Logo

This symbol indicates the requirements of Directive 2012/19/EU regarding the treatment and disposal of waste from electric and electronic equipment.

NOTES



www.pulsarmeasurement.com
SUPPORT@PULSARMEASUREMENT.COM

*Copyright © 2020 Pulsar Measurement Ltd.
Registered Address: 1 Chamberlain Square CS, Birmingham B3 3AX
Registered No.: 3345604 England & Wales
Rev 1.0*